

Application Notes and Protocols for Mitochondrial Toxicity Screening Using Established Positive Controls

Author: BenchChem Technical Support Team. **Date:** April 2026

Compound of Interest

Compound Name: *Gummiferin*

Cat. No.: *B8144436*

[Get Quote](#)

Note: The initially requested compound, "**Gummiferin**," could not be definitively identified as a standard positive control for mitochondrial toxicity. It is presumed to be a misspelling.

Therefore, this document provides a comprehensive overview of well-established and widely used positive controls: Antimycin A, FCCP, Oligomycin, and Rotenone. These compounds represent different mechanisms of mitochondrial toxicity and are suitable for validating a wide range of mitochondrial function assays.

Audience: Researchers, scientists, and drug development professionals.

Introduction to Mitochondrial Toxicity and the Role of Positive Controls

Mitochondria are central to cellular energy production and are involved in a multitude of cellular processes. Drug-induced mitochondrial dysfunction is a significant contributor to cellular toxicity and a major concern in drug development. Mitochondrial toxicity screening assays are

therefore crucial for identifying compounds that may have adverse effects on mitochondrial function.

Positive controls are essential components of these screening assays. They serve to validate the assay's performance, ensure that the experimental system is responsive to mitochondrial toxicants, and provide a benchmark for comparing the effects of test compounds. The positive controls detailed in this document disrupt mitochondrial function through distinct mechanisms, making them valuable tools for a comprehensive assessment of mitochondrial health.

Positive Controls for Mitochondrial Toxicity Screening

This section details the mechanism of action of four commonly used positive controls, provides quantitative data on their effects, and illustrates their impact on mitochondrial signaling pathways.

Antimycin A: Complex III Inhibitor

Mechanism of Action: Antimycin A is a potent inhibitor of the mitochondrial electron transport chain (ETC). It specifically binds to the Qi site of Complex III (cytochrome bc1 complex), blocking the transfer of electrons from cytochrome b to cytochrome c1.^[1] This inhibition halts the electron flow through the ETC, leading to a collapse of the mitochondrial membrane potential ($\Delta\Psi_m$), a decrease in ATP synthesis, and an increase in the production of reactive oxygen species (ROS).^{[1][2]}

Quantitative Data:

Compound	Assay	Cell Line	IC50	Reference
Antimycin A	Cell Growth Inhibition	HeLa	~50 μ M	[3]
Antimycin A	Cell Viability (24h)	HepG2	15.97 nmol/dm ³	[4]
Antimycin A	Oxygen Consumption Rate	HepG2	~10 nM (for 50% inhibition)	
Antimycin A	Apoptosis Induction	A549	50 μ M (induces ~17% apoptosis)	

Signaling Pathway Diagram:

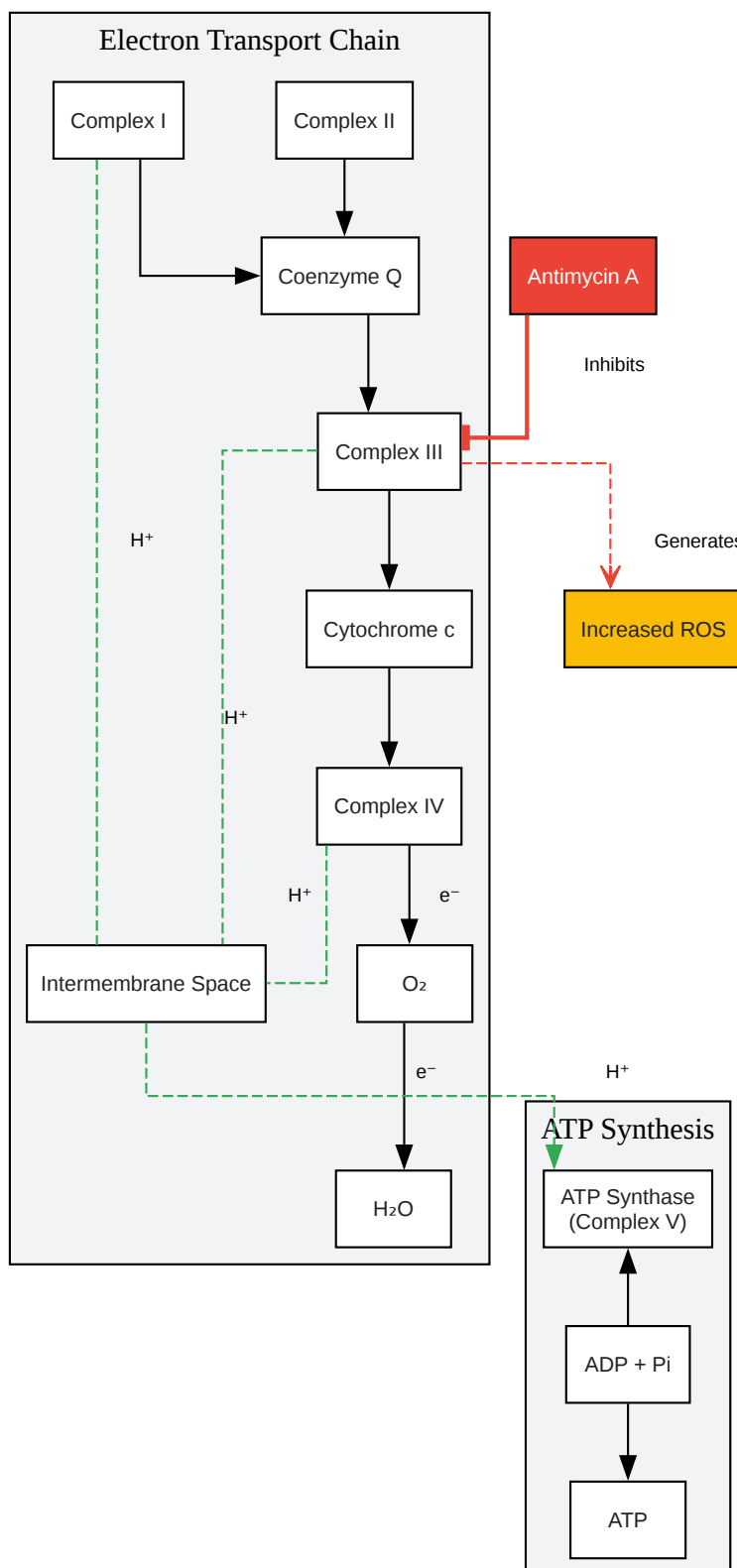

[Click to download full resolution via product page](#)

Mechanism of Antimycin A-induced mitochondrial toxicity.

FCCP: Uncoupler of Oxidative Phosphorylation

Mechanism of Action: Carbonyl cyanide 4-(trifluoromethoxy)phenylhydrazone (FCCP) is a protonophore and a potent uncoupler of oxidative phosphorylation. It disrupts the proton gradient across the inner mitochondrial membrane by transporting protons back into the mitochondrial matrix, bypassing ATP synthase. This uncoupling leads to a rapid dissipation of the mitochondrial membrane potential, an increase in oxygen consumption as the ETC tries to compensate, and a decrease in ATP synthesis.

Quantitative Data:

Compound	Assay	Cell Line	IC50 / Effective Concentration	Reference
FCCP	Mitochondrial Membrane Potential	HepG2	IC50: 44 nM (1h), 116 nM (5h)	
FCCP	Mitochondrial Membrane Potential	Atrial Myocytes	100 nM (partial depolarization), 300 nM (significant depolarization)	
FCCP	Cardioprotection	Rat Hearts	100 nM (optimal concentration)	
FCCP	Mitochondrial Depolarization	Ventricular Myocytes	1 μ M (partial), 10 μ M (maximal)	

Signaling Pathway Diagram:

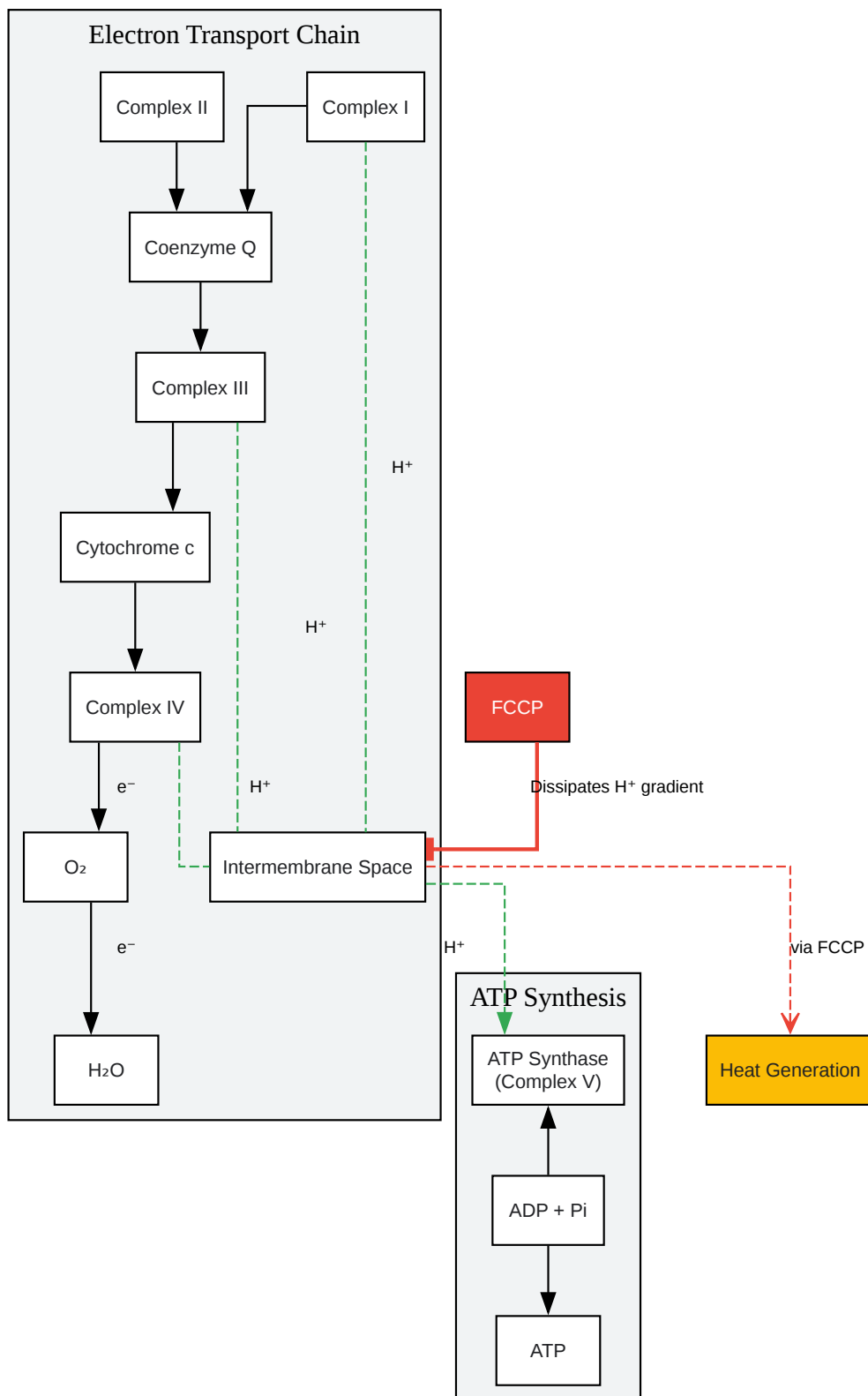

[Click to download full resolution via product page](#)

Mechanism of FCCP-induced mitochondrial uncoupling.

Oligomycin: ATP Synthase Inhibitor

Mechanism of Action: Oligomycin is an inhibitor of F1F0-ATP synthase (Complex V). It binds to the F0 subunit of the ATP synthase, blocking the proton channel and thereby inhibiting the synthesis of ATP. This inhibition leads to a buildup of the proton gradient (hyperpolarization of the mitochondrial membrane) and a subsequent decrease in the rate of electron transport and oxygen consumption.

Quantitative Data:

Compound	Assay	Cell Line	IC50	Reference
Oligomycin A	Mammosphere Formation	MCF7	~100 nM	
Oligomycin A	Mammosphere Formation	MDA-MB-231	~5-10 μ M	
Oligomycin	Store-Operated Ca ²⁺ Influx	Jurkat	~2 μ M	
Oligomycin	Apoptosis Induction	Doxorubicin-Resistant HepG2	Effective	

Signaling Pathway Diagram:

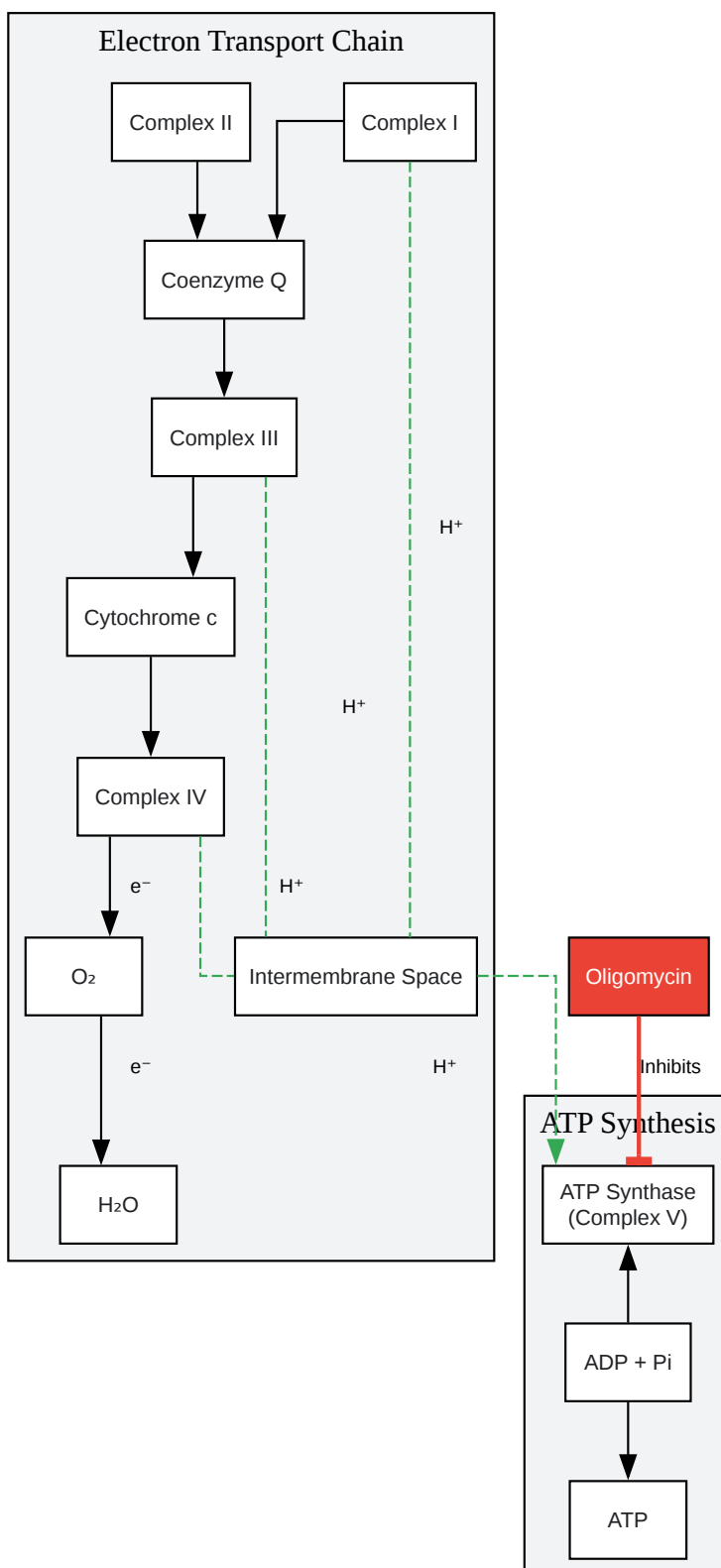

[Click to download full resolution via product page](#)

Mechanism of Oligomycin-induced ATP synthase inhibition.

Rotenone: Complex I Inhibitor

Mechanism of Action: Rotenone is a specific inhibitor of Complex I (NADH:ubiquinone oxidoreductase) of the electron transport chain. It blocks the transfer of electrons from NADH to coenzyme Q, thereby inhibiting oxidative phosphorylation. This leads to a decrease in ATP production, an increase in ROS generation, and can induce apoptosis.

Quantitative Data:

Compound	Assay	Cell Line	IC50	Reference
Rotenone	Cell Viability (24h)	HepG2	56.15 nmol/dm ³	
Rotenone	Cell Viability	MG-63	0.02 μM	
Rotenone	Cell Viability	U2OS	1.09 μM	
Rotenone	Cell Viability	143B	1.35 μM	
Rotenone	Complex I Inhibition	SH-SY5Y	25 nM	

Signaling Pathway Diagram:

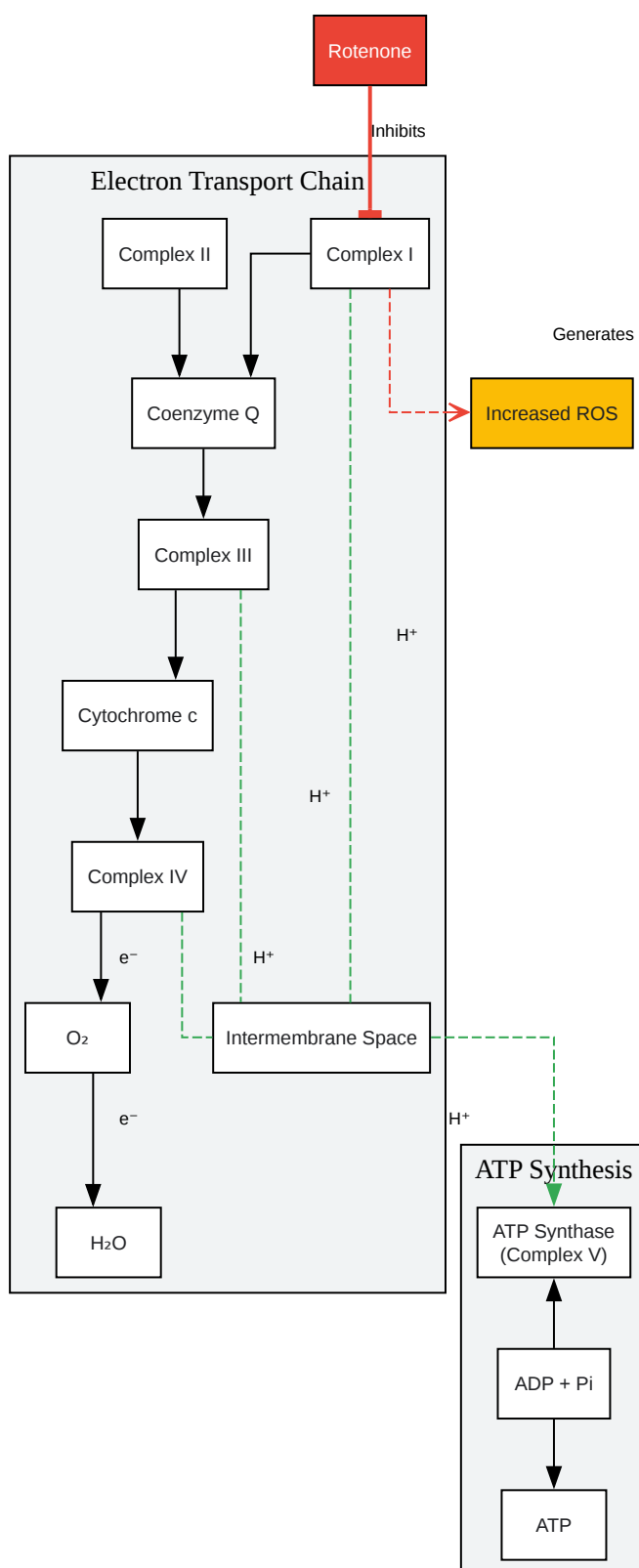

[Click to download full resolution via product page](#)

Mechanism of Rotenone-induced mitochondrial toxicity.

Experimental Protocols

This section provides detailed protocols for three key assays used to screen for mitochondrial toxicity.

Mitochondrial Membrane Potential ($\Delta\Psi_m$) Assay using JC-1

This assay utilizes the cationic dye JC-1 to measure changes in mitochondrial membrane potential. In healthy cells with a high $\Delta\Psi_m$, JC-1 forms aggregates that fluoresce red. In apoptotic or metabolically stressed cells with a low $\Delta\Psi_m$, JC-1 remains as monomers and fluoresces green. A decrease in the red/green fluorescence ratio indicates mitochondrial depolarization.

Experimental Workflow:

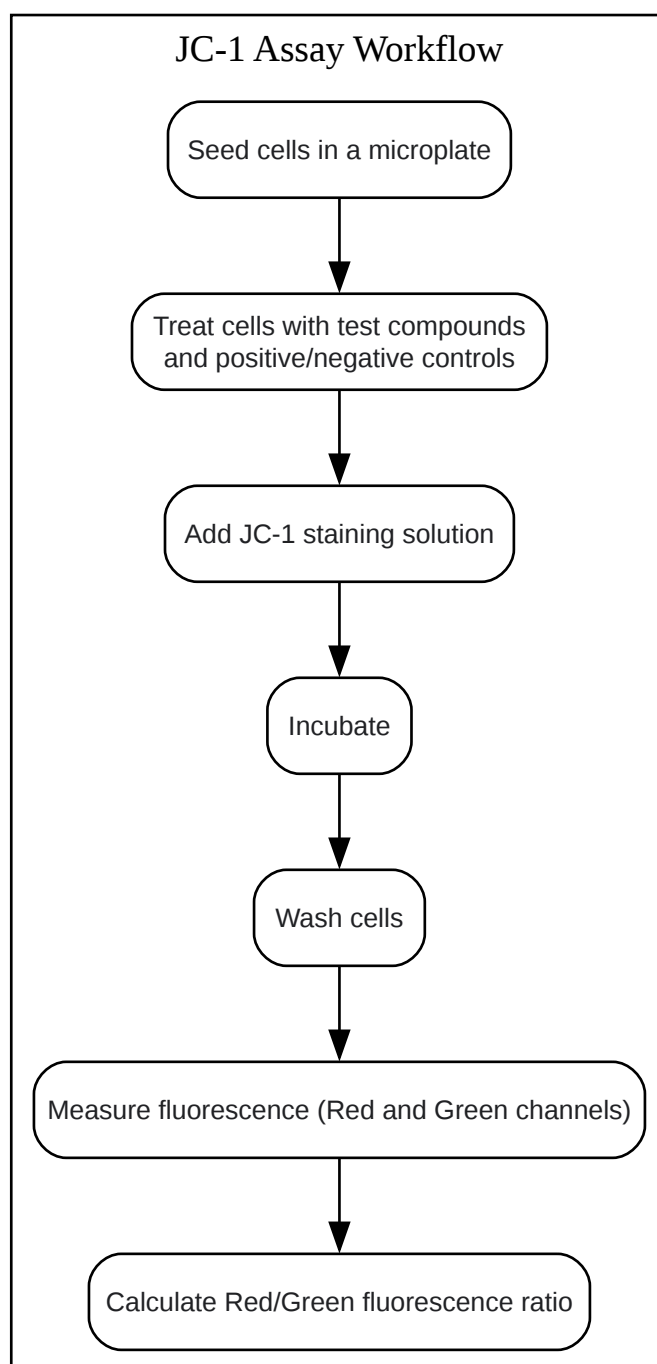

[Click to download full resolution via product page](#)

Workflow for the JC-1 Mitochondrial Membrane Potential Assay.

Protocol for Flow Cytometry:

- **Cell Preparation:** Culture cells to the desired confluence. On the day of the assay, harvest the cells and adjust the cell density to 1×10^6 cells/mL in pre-warmed complete culture medium.
- **Compound Treatment:** Aliquot 1 mL of the cell suspension into flow cytometry tubes. Add test compounds and positive controls (e.g., 10 μ M FCCP for 15-30 minutes) and negative controls (vehicle).
- **JC-1 Staining:** Prepare a 1X JC-1 working solution by diluting a 200X JC-1 stock solution in 1X Assay Buffer. Add 0.5 mL of the JC-1 working solution to each cell pellet.
- **Incubation:** Incubate the cells for 15-30 minutes at 37°C in a CO₂ incubator, protected from light.
- **Washing:** Centrifuge the cells at 400 x g for 5 minutes. Discard the supernatant and wash the cells twice with 1X Assay Buffer.
- **Data Acquisition:** Resuspend the cell pellet in 0.5 mL of 1X Assay Buffer and analyze immediately by flow cytometry. Detect green fluorescence in the FL1 channel and red fluorescence in the FL2 channel.
- **Data Analysis:** Determine the ratio of red to green fluorescence intensity. A decrease in this ratio indicates mitochondrial depolarization.

ATP Depletion Assay

This assay measures the intracellular ATP concentration as an indicator of mitochondrial function. Mitochondrial toxicants that inhibit oxidative phosphorylation will lead to a depletion of cellular ATP levels.

Experimental Workflow:

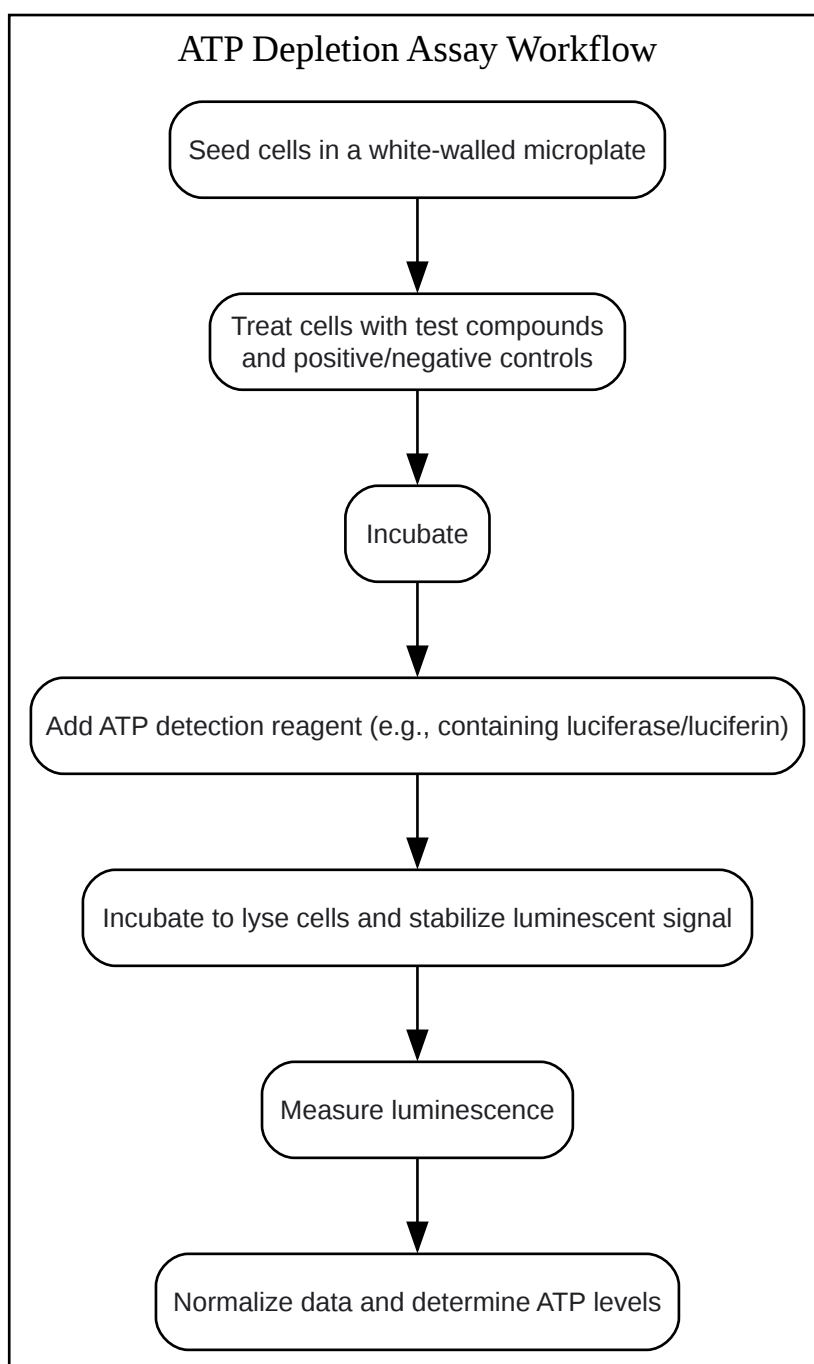

[Click to download full resolution via product page](#)

Workflow for the ATP Depletion Assay.

Protocol:

- **Cell Seeding:** Seed cells in a white, opaque 96-well microplate at a density appropriate for the cell line and allow them to adhere overnight.
- **Compound Treatment:** Remove the culture medium and add fresh medium containing the test compounds, positive controls (e.g., 1 μ M Oligomycin), and a vehicle control.
- **Incubation:** Incubate the plate for the desired time period (e.g., 1, 6, or 24 hours) at 37°C in a CO₂ incubator.
- **Reagent Preparation:** Prepare the ATP detection reagent according to the manufacturer's instructions. This typically involves reconstituting a lyophilized substrate with a buffer.
- **Lysis and Luminescence Reaction:** Add the ATP detection reagent to each well. This reagent lyses the cells and initiates a reaction where luciferase catalyzes the oxidation of luciferin in the presence of ATP, producing light.
- **Signal Stabilization:** Incubate the plate at room temperature for 10-30 minutes to stabilize the luminescent signal.
- **Measurement:** Measure the luminescence using a plate-reading luminometer.
- **Data Analysis:** The luminescent signal is directly proportional to the ATP concentration. Normalize the data to the vehicle control to determine the percentage of ATP depletion.

Oxygen Consumption Rate (OCR) Assay using Seahorse XF Analyzer

The Seahorse XF Analyzer measures the oxygen consumption rate (OCR) and extracellular acidification rate (ECAR) of live cells in real-time, providing a comprehensive profile of cellular metabolism. The Mito Stress Test is a standard assay that uses sequential injections of mitochondrial toxins to assess key parameters of mitochondrial function.

Experimental Workflow:

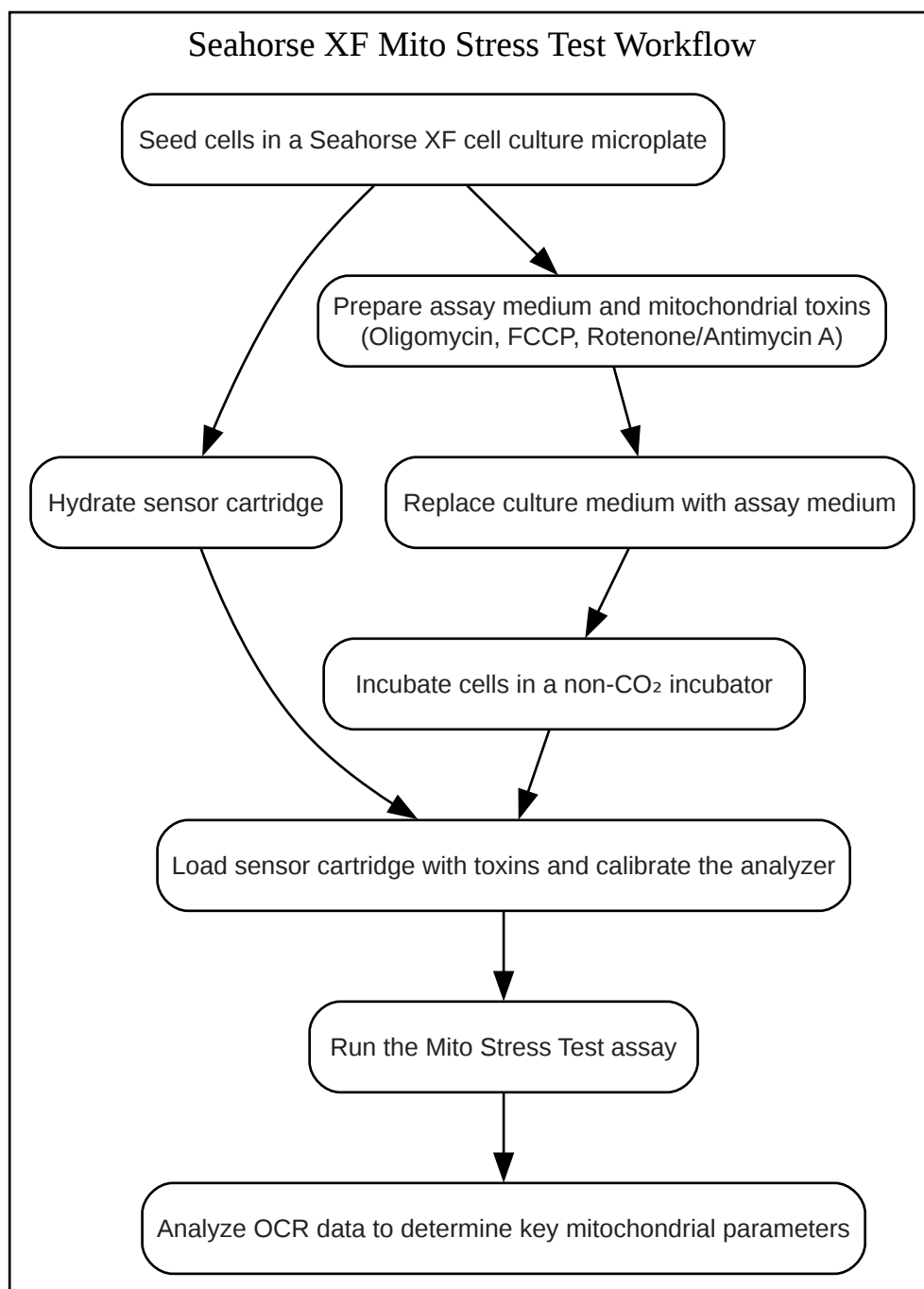

[Click to download full resolution via product page](#)

Need Custom Synthesis?

BenchChem offers custom synthesis for rare earth carbides and specific isotopic labeling.

Email: info@benchchem.com or [Request Quote Online](#).

References

- [1. letstalkacademy.com \[letstalkacademy.com\]](https://letstalkacademy.com)
- [2. Frontiers | Aptly chosen, effectively emphasizing the action and mechanism of antimycin A1 \[frontiersin.org\]](https://frontiersin.org)
- [3. An ROS generator, antimycin A, inhibits the growth of HeLa cells via apoptosis - PubMed \[pubmed.ncbi.nlm.nih.gov\]](https://pubmed.ncbi.nlm.nih.gov)
- [4. How to Use Respiratory Chain Inhibitors in Toxicology Studies—Whole-Cell Measurements - PMC \[pmc.ncbi.nlm.nih.gov\]](https://pmc.ncbi.nlm.nih.gov)
- To cite this document: BenchChem. [Application Notes and Protocols for Mitochondrial Toxicity Screening Using Established Positive Controls]. BenchChem, [2026]. [Online PDF]. Available at: [<https://www.benchchem.com/product/b8144436/docs#application-notes-and-protocols-for-mitochondrial-toxicity-screening-using-established-positive-controls>]

Disclaimer & Data Validity:

The information provided in this document is for Research Use Only (RUO) and is strictly not intended for diagnostic or therapeutic procedures. While BenchChem strives to provide accurate protocols, we make no warranties, express or implied, regarding the fitness of this product for every specific experimental setup.

Technical Support: The protocols provided are for reference purposes. Unsure if this reagent suits your experiment?

Need Industrial/Bulk Grade? [Request Custom Synthesis Quote](#)

BenchChem

Our mission is to be the trusted global source of essential and advanced chemicals, empowering scientists and researchers to drive progress in science and industry.

Contact

Address: 3281 E Guasti Rd
Ontario, CA 91761, United States
Phone: (601) 213-4426
Email: info@benchchem.com

Contact our Ph.D. Support Team for a compatibility check