

A Comparative Analysis of Hosenkoside C and Ginsenosides: A Guide for Researchers

Author: BenchChem Technical Support Team. **Date:** April 2026

Compound of Interest

Compound Name: *Hosenkoside C*

Cat. No.: *B8143437*

[Get Quote](#)

An in-depth comparison of the pharmacological activities, underlying mechanisms, and experimental data for **Hosenkoside C** and the well-studied class of ginsenosides.

This guide provides a comprehensive comparative study of **Hosenkoside C**, a baccharane glycoside, and ginsenosides, a diverse group of triterpenoid saponins. While extensive research has elucidated the multifaceted therapeutic potential of ginsenosides, data on **Hosenkoside C** is comparatively limited, necessitating a careful and objective analysis of the available scientific literature. This document is intended for researchers, scientists, and drug development professionals interested in the pharmacological properties of these natural compounds.

Structural and Chemical Profile

Hosenkoside C is a baccharane-type triterpenoid saponin isolated from the seeds of *Impatiens balsamina*[1]. Ginsenosides, on the other hand, are primarily dammarane-type triterpenoids derived from the roots, stems, leaves, and fruits of *Panax ginseng*[2]. They are broadly classified into protopanaxadiol (PPD) and protopanaxatriol (PPT) types based on the hydroxylation pattern of their aglycone core. This fundamental structural difference between the

baccharane skeleton of **Hosenkoside C** and the dammarane skeleton of ginsenosides is a key determinant of their respective biological activities.

Comparative Pharmacological Activities

While direct comparative studies between **Hosenkoside C** and ginsenosides are scarce, an analysis of their individual pharmacological activities provides valuable insights.

Anti-inflammatory Activity

Both **Hosenkoside C** and various ginsenosides have demonstrated anti-inflammatory properties. **Hosenkoside C** has been shown to suppress the production of pro-inflammatory cytokines and nitric oxide (NO) in experimental models[1]. However, specific quantitative data, such as IC50 values, for purified **Hosenkoside C** are not readily available in the current literature. One study on an ethanol extract of *Impatiens balsamina* seeds, which contains **Hosenkoside C**, reported an IC50 value of 210 µg/mL in a protein denaturation assay, suggesting general anti-inflammatory potential[3].

In contrast, the anti-inflammatory effects of numerous ginsenosides have been extensively quantified. For instance, in a study evaluating six different ginsenosides in lipopolysaccharide (LPS)-stimulated RAW 264.7 macrophages, Rg3 and Rf were found to be the most effective in reducing the expression of inflammatory cytokines[4]. Another study reported that a mixture of transformed minor ginsenosides (GRg3-mix) containing Rg3(S), Rg3(R), Rg5, and Rk1 decreased NO production in a dose-dependent manner in LPS-induced RAW 264.7 cells, with significant effects observed at concentrations ranging from 6.25 to 50 µg/mL[5]. The ginsenoside metabolite Compound K (CK) and ginsenoside Rh1 have also been shown to significantly reduce the production of NO, cyclooxygenase-2 (COX-2), and pro-inflammatory cytokines in a dose-dependent manner[6].

Table 1: Comparative Anti-inflammatory Activity Data

Compound/Extract	Model System	Target/Assay	Quantitative Data (IC50 or % Inhibition)
Impatiens balsamina seed extract (proxy for Hosenkoside C)	Protein Denaturation (BSA)	Protein Denaturation	IC50: 210 µg/mL[3]
Ginsenoside Rg3	LPS-stimulated RAW 264.7 cells	TNF-α mRNA reduction	Significant reduction at 25 µM and 50 µM[4]
Ginsenoside Rf	LPS-stimulated RAW 264.7 cells	TNF-α mRNA reduction	Significant reduction at 25 µM and 50 µM[4]
GRg3-mix (containing Rg3, Rg5, Rk1)	LPS-stimulated RAW 264.7 cells	NO Production	Dose-dependent decrease (6.25–50 µg/mL)[5]
Compound K (CK)	LPS-stimulated RAW 264.7 cells	NO Production	Dose-dependent reduction[6]
Ginsenoside Rh1	LPS-stimulated RAW 264.7 cells	NO Production	Dose-dependent reduction[6]

Anticancer Activity

Extracts of *Sanghuangporus vaninii*, which contain **Hosenkoside C**, have demonstrated inhibitory effects on the proliferation of SW480 human colon cancer cells[1]. However, this activity is attributed to the entire extract, and no specific IC50 values for purified **Hosenkoside C** have been reported.

The anticancer activities of ginsenosides are well-documented across various cancer types. The efficacy of ginsenosides is often structure-dependent, with a decrease in the number of sugar moieties generally correlating with increased anticancer activity[4]. For example, ginsenoside Rh2 has an IC50 value of 39.50 µM in HCT15 colorectal cancer cells, while a ginsenoside-enriched black ginseng extract (Rg3/Rg5-BG) showed an IC50 of 3.0 mg/mL in HCT116 cells[2][7]. The ginsenoside metabolite Compound K (CK) has demonstrated

significant anti-proliferative effects on colon cancer cells, with an IC₅₀ for inhibiting cell proliferation and inducing apoptosis in the range of 30-50 μM[3].

Table 2: Comparative Anticancer Activity Data (Colorectal Cancer)

Compound/Extract	Cell Line	Assay	IC ₅₀ Value
Hosenkoside C	SW480	Proliferation	Data not available for purified compound[1]
Total Ginsenosides of Chinese Ginseng (TGCG)	HT-29	Cell Viability	124.63 μg/mL (48h)[2]
Ginseng Extract	RKO	Cell Viability	140 μg/mL[7]
Ginsenoside Rh2	HCT15	Cell Viability	39.50 μM[2]
Rg3/Rg5-BG Extract	HCT116	Cell Viability	3.0 mg/mL[7]
Compound K (CK)	HCT-116, SW-480	Proliferation/Apoptosis	30-50 μM[3]

Cardioprotective Activity

Hosenkoside C has been suggested to possess cardioprotective potential by regulating blood pressure and improving endothelial function[8]. However, quantitative data to support these claims are lacking in the available literature.

In contrast, numerous studies have provided quantitative evidence for the cardioprotective effects of ginsenosides. For instance, ginsenoside Rb1 has been shown to protect against myocardial ischemia/reperfusion injury[9][10]. Total ginsenosides have been demonstrated to increase coronary perfusion flow in a dose-dependent manner[11]. Ginsenoside Rc reduced the levels of cardiac injury markers CK-MB and troponin T in a myocardial ischemia mouse model[6].

Mechanisms of Action and Signaling Pathways

The therapeutic effects of both **Hosenkoside C** and ginsenosides are attributed to their ability to modulate key intracellular signaling pathways.

Hosenkoside C

The precise signaling pathways modulated by **Hosenkoside C** are not yet fully elucidated. However, based on the activities of other natural saponins, it is hypothesized to exert its anti-inflammatory effects through the inhibition of the Nuclear Factor-kappa B (NF- κ B) signaling pathway[3]. NF- κ B is a crucial transcription factor that regulates the expression of numerous pro-inflammatory genes.

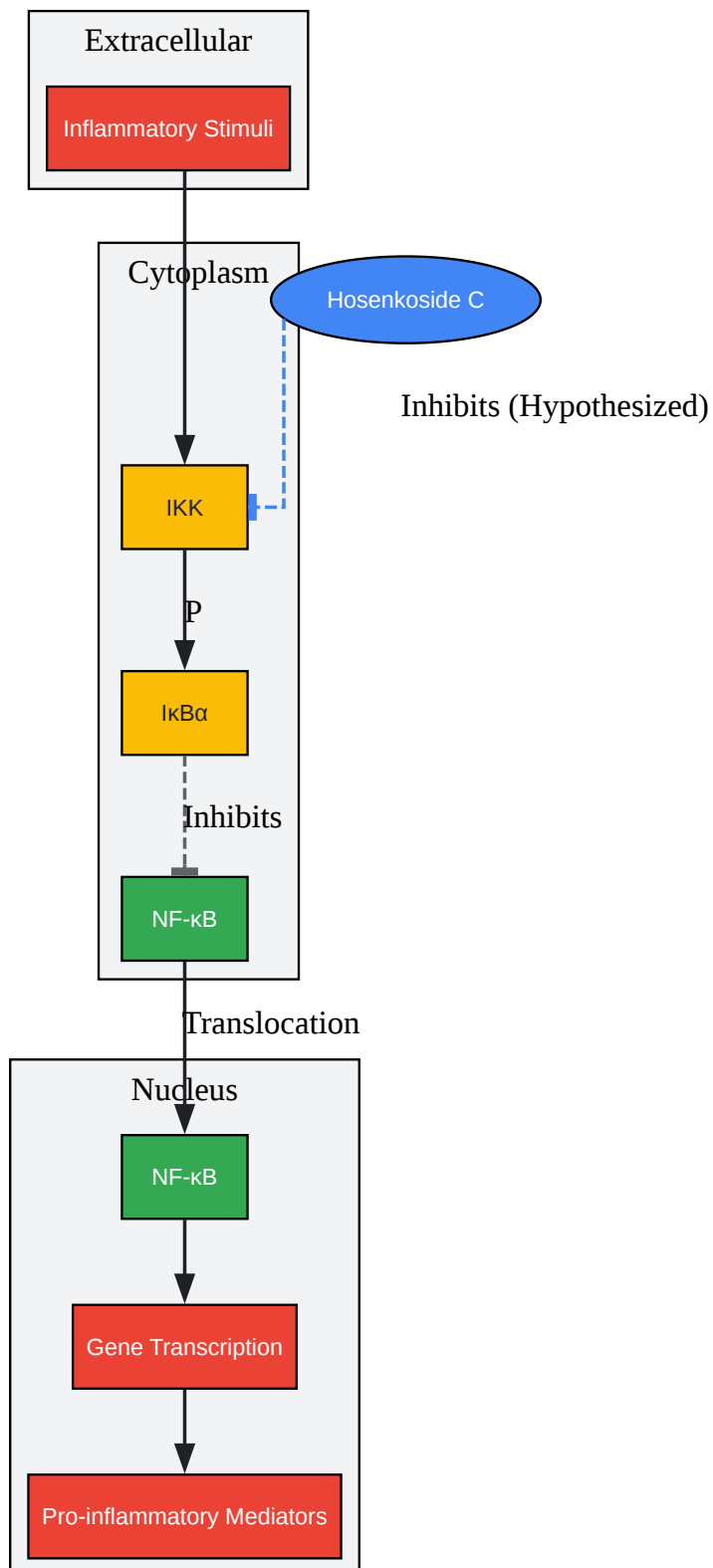

[Click to download full resolution via product page](#)

Hypothesized NF-κB inhibitory pathway of **Hosenkoside C**.

Ginsenosides

Ginsenosides have been shown to modulate a complex network of signaling pathways, including:

- **PI3K/Akt Pathway:** This pathway is crucial for cell survival, proliferation, and growth. Several ginsenosides, including Compound K, have been shown to inhibit the PI3K/Akt/mTOR pathway in cancer cells, leading to reduced proliferation and invasion[12][13][14].
- **MAPK Pathway:** The Mitogen-Activated Protein Kinase (MAPK) pathway is involved in cellular processes like inflammation, proliferation, and apoptosis. Ginsenosides such as Rd have been found to block MAPK signaling by inhibiting the phosphorylation of ERK and p38 MAPK[15][16].
- **NF- κ B Pathway:** Many ginsenosides exert their anti-inflammatory effects by suppressing the NF- κ B pathway. They can inhibit the degradation of I κ B α , thereby preventing the nuclear translocation of NF- κ B and the subsequent transcription of pro-inflammatory genes[17][18].

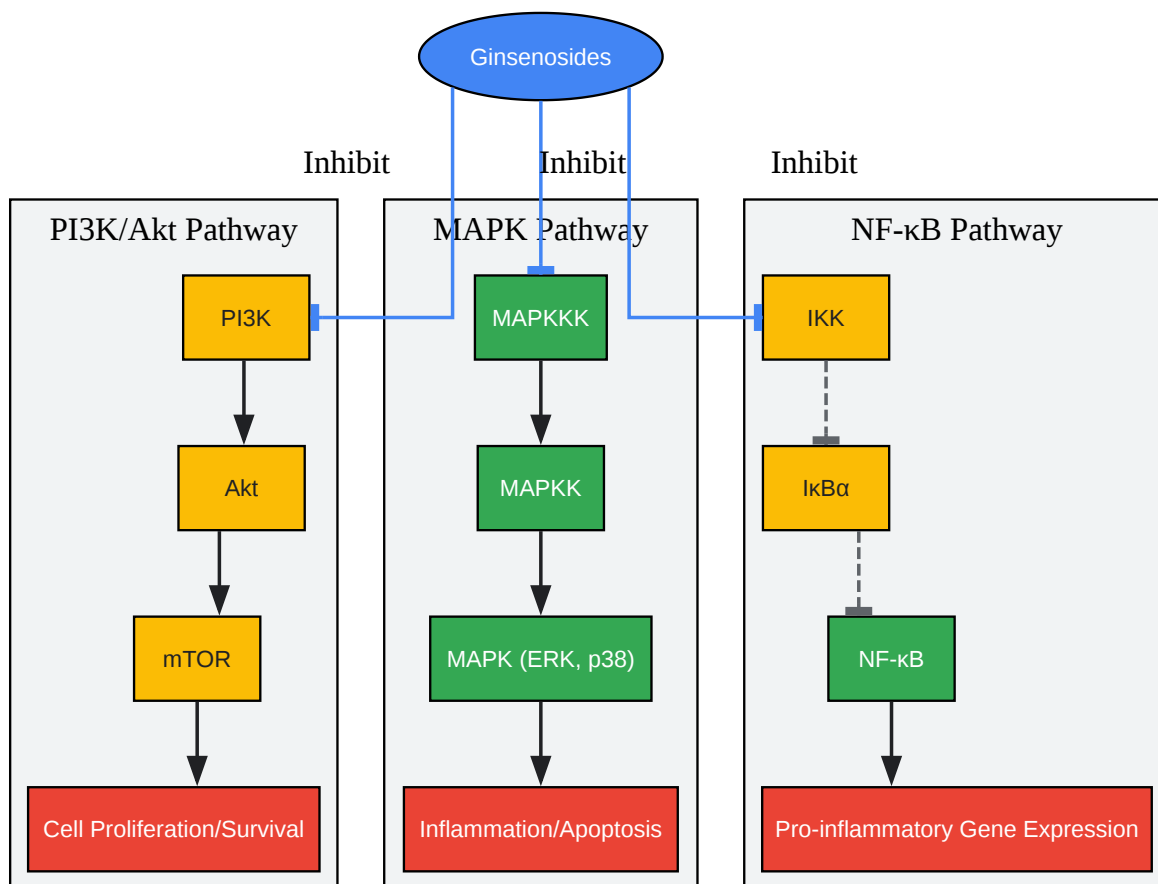

[Click to download full resolution via product page](#)

Key signaling pathways modulated by ginsenosides.

Experimental Protocols

Detailed methodologies are essential for the reproducibility and advancement of scientific research. Below are representative protocols for key experiments cited in the literature.

Isolation of Hosenkoside C and Ginsenosides

A general workflow for the isolation of these saponins from their plant sources is outlined below.



[Click to download full resolution via product page](#)

General workflow for saponin isolation.

Protocol for Saponin Extraction and Isolation:

- Preparation of Plant Material: The dried plant material (e.g., Impatiens balsamina seeds for **Hosenkoside C** or Panax ginseng roots for ginsenosides) is ground into a fine powder to increase the surface area for extraction.
- Solvent Extraction: The powdered material is extracted with a suitable solvent, typically methanol or ethanol, using methods such as Soxhlet extraction, maceration, or ultrasonication.
- Filtration and Concentration: The resulting extract is filtered to remove solid plant debris and then concentrated under reduced pressure using a rotary evaporator to yield a crude extract.
- Chromatographic Purification: The crude extract is subjected to a series of chromatographic techniques to isolate the target compounds. This may include:
 - Liquid-Liquid Partitioning: To separate compounds based on polarity.
 - Column Chromatography: Using stationary phases like silica gel or reversed-phase C18.
 - High-Performance Liquid Chromatography (HPLC): For final purification to obtain the compound of interest with high purity.

In Vitro Anti-inflammatory Assay (Nitric Oxide Production)

This assay is widely used to assess the anti-inflammatory activity of compounds by measuring their ability to inhibit NO production in LPS-stimulated macrophages.

Protocol:

- **Cell Culture:** Murine macrophage cells (e.g., RAW 264.7) are cultured in a suitable medium (e.g., DMEM with 10% FBS).
- **Cell Treatment:** Cells are seeded in 96-well plates and pre-treated with various concentrations of the test compound (**Hosenkoside C** or a specific ginsenoside) for 1-2 hours.
- **Inflammation Induction:** Inflammation is induced by adding lipopolysaccharide (LPS; e.g., 1 µg/mL) to the cell culture and incubating for an additional 24 hours.
- **Nitric Oxide Measurement:** The concentration of nitrite, a stable product of NO, in the cell culture supernatant is measured using the Griess reagent. The absorbance is read at a specific wavelength (e.g., 540 nm).
- **Data Analysis:** The percentage of NO inhibition is calculated by comparing the nitrite concentration in the treated groups to the LPS-only control group. The IC₅₀ value can then be determined from the dose-response curve.

Conclusion and Future Directions

This comparative guide highlights the significant body of research on the pharmacological activities of ginsenosides, with a wealth of quantitative data supporting their anti-inflammatory, anticancer, and cardioprotective effects. The mechanisms of action for many ginsenosides have been extensively studied, revealing their modulation of key signaling pathways such as PI3K/Akt, MAPK, and NF-κB.

In contrast, while **Hosenkoside C** shows promise as a bioactive compound with similar therapeutic potential, the current scientific literature lacks the specific quantitative data necessary for a direct and robust comparison with ginsenosides. Future research should focus on:

- Quantitative evaluation of the pharmacological activities of purified **Hosenkoside C** to determine its potency (e.g., IC₅₀ values) in standardized in vitro and in vivo models.
- Elucidation of the specific molecular targets and signaling pathways modulated by **Hosenkoside C** to understand its precise mechanisms of action.

- Direct comparative studies evaluating **Hosenkoside C** and various ginsenosides in the same experimental systems to provide a definitive assessment of their relative efficacy.

Such studies will be crucial for unlocking the full therapeutic potential of **Hosenkoside C** and for providing a solid scientific basis for its further development as a potential therapeutic agent.

Need Custom Synthesis?

BenchChem offers custom synthesis for rare earth carbides and specific isotopic labeling.

Email: info@benchchem.com or [Request Quote Online](#).

References

- [1. Hosenkoside C | Benchchem \[benchchem.com\]](#)
- [2. Total ginsenosides of Chinese ginseng induces cell cycle arrest and apoptosis in colorectal carcinoma HT-29 cells - PMC \[pmc.ncbi.nlm.nih.gov\]](#)
- [3. benchchem.com \[benchchem.com\]](#)
- [4. mdpi.com \[mdpi.com\]](#)
- [5. Repressing effect of transformed ginsenoside Rg3-mix against LPS-induced inflammation in RAW264.7 macrophage cells - PMC \[pmc.ncbi.nlm.nih.gov\]](#)
- [6. researchgate.net \[researchgate.net\]](#)
- [7. Ginseng mediates its anticancer activity by inhibiting the expression of DNMTs and reactivating methylation-silenced genes in colorectal cancer - PMC \[pmc.ncbi.nlm.nih.gov\]](#)
- [8. researchgate.net \[researchgate.net\]](#)
- [9. researchgate.net \[researchgate.net\]](#)
- [10. Effects of Panax ginseng and ginsenosides on oxidative stress and cardiovascular diseases: pharmacological and therapeutic roles - PMC \[pmc.ncbi.nlm.nih.gov\]](#)
- [11. A review on the medicinal potentials of ginseng and ginsenosides on cardiovascular diseases - PMC \[pmc.ncbi.nlm.nih.gov\]](#)
- [12. Anticancer Activities of Ginsenosides, the Main Active Components of Ginseng - PMC \[pmc.ncbi.nlm.nih.gov\]](#)
- [13. Regulation of Nuclear Factor-KappaB \(NF-κB\) signaling pathway by non-coding RNAs in cancer: Inhibiting or promoting carcinogenesis? - PubMed \[pubmed.ncbi.nlm.nih.gov\]](#)

- [14. Modulation of the PI3K/Akt/mTOR signaling pathway by probiotics as a fruitful target for orchestrating the immune response - PubMed \[pubmed.ncbi.nlm.nih.gov\]](#)
- [15. Anti-metastatic effects of ginsenoside Rd via inactivation of MAPK signaling and induction of focal adhesion formation - PubMed \[pubmed.ncbi.nlm.nih.gov\]](#)
- [16. The promising therapeutic potentials of ginsenosides mediated through p38 MAPK signaling inhibition - PMC \[pmc.ncbi.nlm.nih.gov\]](#)
- [17. jocpr.com \[jocpr.com\]](#)
- [18. Pro-Resolving Effect of Ginsenosides as an Anti-Inflammatory Mechanism of Panax ginseng - PMC \[pmc.ncbi.nlm.nih.gov\]](#)
- To cite this document: BenchChem. [A Comparative Analysis of Hosenkoside C and Ginsenosides: A Guide for Researchers]. BenchChem, [2026]. [Online PDF]. Available at: [<https://www.benchchem.com/product/b8143437/docs#a-comparative-analysis-of-hosenkoside-c-and-ginsenosides-a-guide-for-researchers>]

Disclaimer & Data Validity:

The information provided in this document is for Research Use Only (RUO) and is strictly not intended for diagnostic or therapeutic procedures. While BenchChem strives to provide accurate protocols, we make no warranties, express or implied, regarding the fitness of this product for every specific experimental setup.

Technical Support: The protocols provided are for reference purposes. Unsure if this reagent suits your experiment?

Need Industrial/Bulk Grade? [Request Custom Synthesis Quote](#)

BenchChem

Our mission is to be the trusted global source of essential and advanced chemicals, empowering scientists and researchers to drive progress in science and industry.

Contact

Address: 3281 E Guasti Rd

Ontario, CA 91761, United States

Phone: (601) 213-4426

Email: info@benchchem.com

Contact our Ph.D. Support Team for a compatibility check