

Cyclic Enaminone Building Blocks for Organic Synthesis

Author: BenchChem Technical Support Team. **Date:** April 2026

Compound of Interest

Compound Name: *3-Amino-5-ethylcyclohex-2-en-1-one*
Cat. No.: *B8140891*

[Get Quote](#)

Executive Summary

Cyclic enaminones (

-amino-cyclic-

-unsaturated ketones) represent a privileged scaffold in organic synthesis, distinguished by their "push-pull" electronic architecture. This unique conjugation—bridging an electron-donating amine and an electron-withdrawing carbonyl through a vinyl spacer—endows the system with ambident nucleophilicity and electrophilicity. This guide provides a comprehensive technical analysis of cyclic enaminones, detailing their electronic properties, robust synthetic protocols, and critical role as intermediates in the total synthesis of complex alkaloids (e.g., Lycopodine) and anticonvulsant drug discovery.

Structural & Electronic Properties

The utility of cyclic enaminones stems from their ability to stabilize dipolar resonance forms. Unlike simple enamines, which are moisture-sensitive, the conjugation with the carbonyl group renders enaminones stable to hydrolysis while maintaining high reactivity toward specific electrophiles.

The "Push-Pull" Effect

The nitrogen lone pair donates electron density into the

-system ("push"), while the carbonyl oxygen accepts it ("pull"). This creates distinct regions of reactivity:

- Nucleophilic Sites: Nitrogen, Oxygen, C-2, and C-4, (if extended).
- Electrophilic Sites: Carbonyl Carbon (C-1) and C-3.

Reactivity Map

The following diagram illustrates the resonance contributions and the resulting reactive sites that allow for regioselective functionalization.

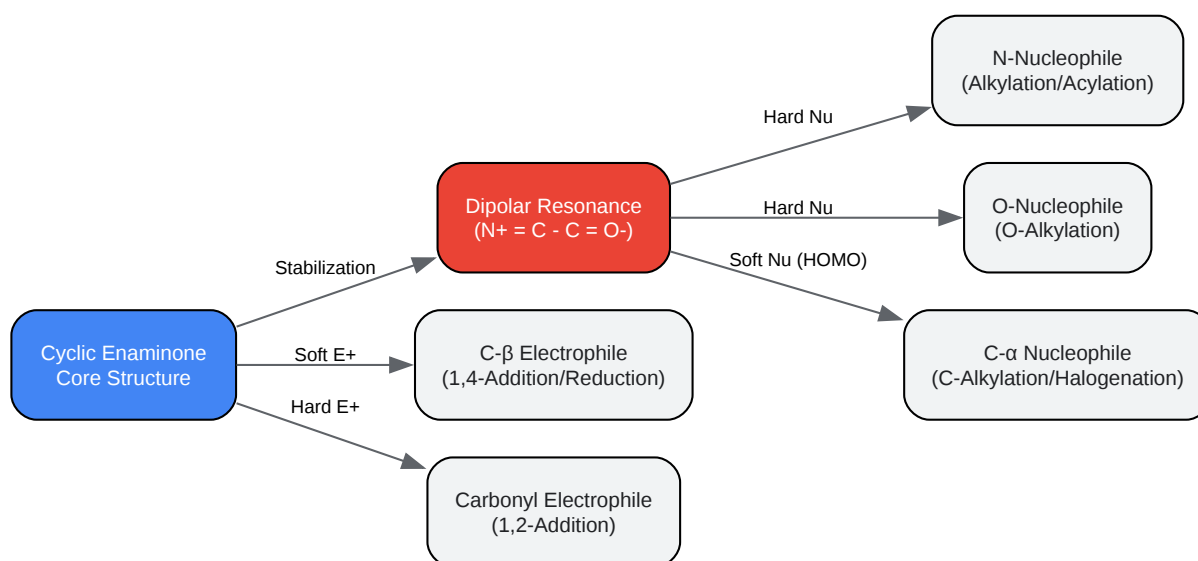

[Click to download full resolution via product page](#)

Caption: Reactivity profile of cyclic enaminones showing ambident nucleophilic and electrophilic sites driven by electronic push-pull resonance.

Synthetic Strategies

Constructing the cyclic enaminone core requires methods that balance thermodynamic stability with kinetic control.

Method A: Condensation of 1,3-Diketones (Standard)

The most scalable approach involves the condensation of cyclic 1,3-diketones (e.g., cyclohexane-1,3-dione, dimedone) with primary or secondary amines.

- Mechanism: Acid-catalyzed nucleophilic attack of the amine on the carbonyl, followed by dehydration.
- Critical Control: Azeotropic removal of water (Dean-Stark) is essential to drive the equilibrium forward.
- Scope: Excellent for aliphatic and aromatic amines.

Method B: Catalytic/Modern Approaches

Recent advances utilize transition metal catalysis to access enaminones from less oxidized precursors.

- Photoredox/Ni Catalysis: Coupling of 3-bromochromones with amines.^[1]
- Ketene Cyclization: Reaction of diazo compounds with amines and alkynes via Wolff rearrangement.

Comparative Analysis of Synthetic Methods

| Method | Precursors | Catalyst/Reagent | Yield | Scalability | Key Advantage |
|-------------------|-------------------------|--------------------------------|--------|------------------|---|
| Condensation | 1,3-Diketone + Amine | p-TSA / NH ₄ OAc | 85-95% | High (Gram-Kilo) | Simple, cost-effective, no metal waste. |
| Eschweiler-Clarke | 1,3-Diketone + Amine | Formic acid | 70-85% | Medium | Reductive alkylation in one pot. |
| Photoredox | 3-Bromochromone | Ni(II) / Light | 60-80% | Low (mg scale) | Access from chromones; mild conditions. |
| Solid State | 1,3-Diketone + Amine | SiO ₂ / Grinding | 90%+ | Low-Medium | Solvent-free, Green Chemistry. |

Applications in Complex Molecule Synthesis

Cyclic enaminones are not just end-products but versatile intermediates for constructing alkaloid skeletons and bioactive pharmacophores.

Case Study: Total Synthesis of (+)-Lycopodine

The Lycopodium alkaloids, particularly (+)-Lycopodine, feature a tetracyclic core.[2] The Heathcock and Sha syntheses utilize a cyclic enaminone intermediate to construct the A and B rings.

- Role: The enaminone serves as a stable vinylogous amide that directs regioselective alkylation and subsequent Mannich cyclization.
- Mechanism: The "push" from the nitrogen activates the α -carbon for alkylation, while the carbonyl remains available for later cyclization.

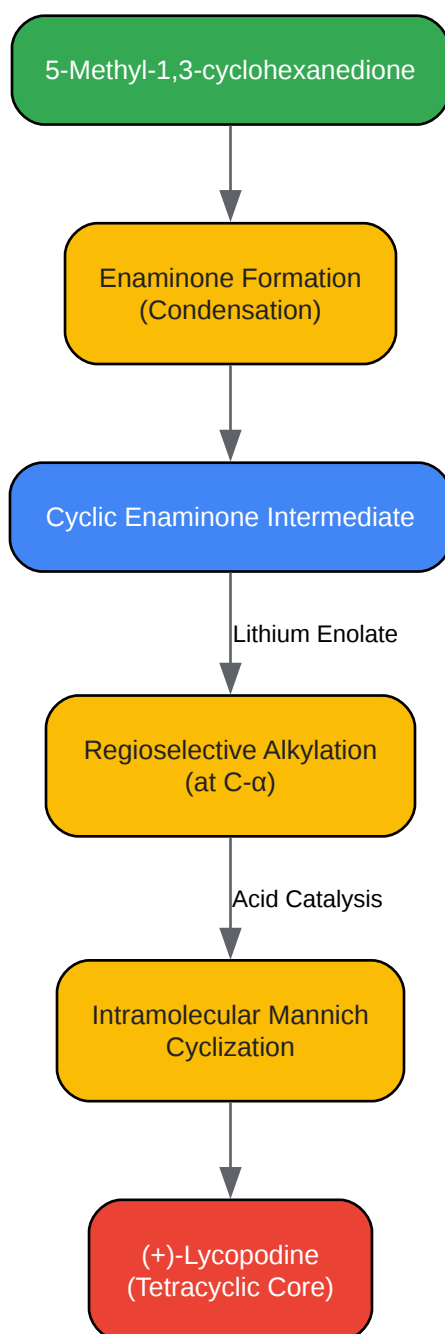

[Click to download full resolution via product page](#)

Caption: Strategic use of cyclic enaminone intermediate in the total synthesis of (+)-Lycopodine.

Case Study: Anticonvulsant Drug Discovery

Cyclic enaminones have demonstrated potent anticonvulsant activity with low neurotoxicity.[3]

- Compound 27: Methyl 4-[(p-chlorophenyl)amino]-6-methyl-2-oxo-cyclohex-3-en-1-oate.[3]
- Activity: Protective in maximal electroshock (MES) seizure tests (ED50 = 5.8 mg/kg in rats). [3]
- Mechanism: Modulation of sodium channels and GABAergic pathways. The enaminone moiety acts as a pharmacophore mimicking the anticonvulsant properties of phenytoin but with a wider therapeutic index.

Experimental Protocols

The following protocols are standardized for high reproducibility.

Protocol 1: Synthesis of 3-Aminocyclohex-2-enone

Objective: Preparation of the unsubstituted enaminone core. Reagents: 1,3-Cyclohexanedione (1.0 eq), Ammonium Acetate (1.3 eq), Toluene or Benzene.

- Setup: Equip a 250 mL round-bottom flask with a magnetic stir bar and a Dean-Stark trap fitted with a reflux condenser.
- Reaction: Charge the flask with 1,3-cyclohexanedione (11.2 g, 100 mmol) and ammonium acetate (10.0 g, 130 mmol). Add Toluene (100 mL).
- Reflux: Heat the mixture to reflux (bath temp ~120°C). Water will separate in the Dean-Stark trap. Continue reflux until water evolution ceases (approx. 3-4 hours).
- Workup: Cool the reaction to room temperature. The product may precipitate. If soluble, evaporate the solvent under reduced pressure.
- Purification: Recrystallize the crude solid from Ethyl Acetate/Hexanes.
- Yield: Expected yield 85-93%. Product appears as yellow crystals.

Protocol 2: Synthesis of N-Benzyl-5,5-dimethyl-3-aminocyclohex-2-enone

Objective: Synthesis of a substituted enaminone (Dimedone derivative). Reagents: Dimedone (1.0 eq), Benzylamine (1.1 eq), Toluene.

- Setup: 3-neck flask with Dean-Stark apparatus.
- Reaction: Dissolve Dimedone (1.40 g, 10 mmol) in Toluene (30 mL). Add Benzylamine (1.2 mL, 11 mmol).
- Reflux: Reflux for 3 hours with azeotropic water removal.
- Monitoring: Monitor via TLC (SiO₂, 50% EtOAc/Hexane).
- Isolation: Remove solvent in vacuo. The resulting oil typically solidifies upon standing or triturating with cold ether.
- Characterization:
 - ¹H NMR (CDCl₃):
1.05 (s, 6H), 2.18 (s, 2H), 2.25 (s, 2H), 4.25 (d, 2H), 5.10 (s, 1H, vinyl), 5.80 (br s, 1H, NH), 7.30 (m, 5H).

References

- Synthesis of 6- and 7-membered cyclic enaminones: Scope and mechanism. Source: National Institutes of Health (PMC) URL:[[Link](#)]
- Cyclic enaminones.[3][4][5] Part II: applications as versatile intermediates in alkaloid synthesis. Source: Chemical Communications (RSC) URL:[[Link](#)]
- Synthesis and anticonvulsant activity of enaminones. Source: Journal of Medicinal Chemistry (via PubMed) URL:[[Link](#)]
- Synthesis of cis- and trans-3-Aminocyclohexanols by Reduction of β-Enaminoketones. Source: Molbank (MDPI) URL:[[Link](#)]
- Total Synthesis of the Lycopodium Alkaloid (+)-Serratezomine A. Source: Journal of the American Chemical Society (via PMC) URL:[[Link](#)]

Need Custom Synthesis?

BenchChem offers custom synthesis for rare earth carbides and specific isotopic labeling.

Email: info@benchchem.com or [Request Quote Online](#).

Sources

- 1. BJOC - General method for the synthesis of enaminones via photocatalysis [beilstein-journals.org]
- 2. mdpi.com [mdpi.com]
- 3. Synthesis and anticonvulsant activity of enaminones - PubMed [pubmed.ncbi.nlm.nih.gov]
- 4. pubs.acs.org [pubs.acs.org]
- 5. Synthesis, antibacterial and anticonvulsant evaluations of some cyclic enaminones - PubMed [pubmed.ncbi.nlm.nih.gov]
- To cite this document: BenchChem. [Cyclic Enaminone Building Blocks for Organic Synthesis]. BenchChem, [2026]. [Online PDF]. Available at: [<https://www.benchchem.com/product/b8140891/docs#cyclic-enaminone-building-blocks-for-organic-synthesis>]

Disclaimer & Data Validity:

The information provided in this document is for Research Use Only (RUO) and is strictly not intended for diagnostic or therapeutic procedures. While BenchChem strives to provide accurate protocols, we make no warranties, express or implied, regarding the fitness of this product for every specific experimental setup.

Technical Support: The protocols provided are for reference purposes. Unsure if this reagent suits your experiment?

Need Industrial/Bulk Grade? [Request Custom Synthesis Quote](#)

BenchChem

Our mission is to be the trusted global source of essential and advanced chemicals, empowering scientists and researchers to drive progress in science and industry.

Contact

Address: 3281 E Guasti Rd

Ontario, CA 91761, United States

Phone: (601) 213-4426

Email: info@benchchem.com

[Contact our Ph.D. Support Team for a compatibility check](#)