

Technical Support Center: Optimizing 2-Chloro-3-methoxy-4-pyridinamine Couplings

Author: BenchChem Technical Support Team. **Date:** April 2026

Compound of Interest

Compound Name: *2-Chloro-3-methoxy-4-pyridinamine hydrochloride*

Cat. No.: *B8139761*

[Get Quote](#)

Ticket ID: #PYR-2CL-3OME-OPT Subject: Yield Improvement & Troubleshooting for Sterically Congested Aminopyridines Assigned Specialist: Senior Application Scientist, Process Chemistry Division

Executive Summary: The "Yield Trap"

The scaffold 2-Chloro-3-methoxy-4-pyridinamine presents a classic "push-pull" conflict in transition-metal catalysis. You are likely experiencing low yields (10–40%) or stalled conversion. This is rarely a random failure; it is a structural inevitability caused by three converging factors:

- **Electronic Deactivation:** The electron-donating 4-amino and 3-methoxy groups increase electron density on the pyridine ring, making the C2-Cl bond significantly less electrophilic compared to a standard 2-chloropyridine. This slows down the Oxidative Addition step in Pd-catalyzed cycles.
- **The "Ortho-Ortho" Steric Wall:** The 3-methoxy group acts as a steric gatekeeper. It hinders the approach of bulky active catalyst species to the C2-position and distorts the geometry required for planar transition states.

- Catalyst Poisoning: The free 4-amino group () and the pyridine nitrogen () are competent ligands. They can displace your expensive phosphine ligands, forming inactive Palladium-Amine "black" complexes.

Module 1: Coupling at the C2-Chlorine (Suzuki/Stille/Negishi)

Objective: Building Carbon-Carbon bonds at the 2-position.

Q1: My Suzuki coupling stalls at 30% conversion. Adding more catalyst doesn't help. Why?

Diagnosis: You are likely suffering from Oxidative Addition Stagnation combined with Catalyst Deactivation. The C2-Cl bond is electron-rich and sterically crowded. Standard catalysts (e.g.,

or

) are too bulky and not electron-rich enough to insert effectively.

The Solution: The "Active & Small" Protocol You need a ligand that is electron-rich (to facilitate oxidative addition into the deactivated Cl) but spatially optimized to navigate the 3-OMe steric bulk.

- Recommended Catalyst:
 - + SPhos or XPhos Pd G3/G4.
 - Why: SPhos is a Buchwald dialkylbiaryl phosphine designed for sterically hindered aryl chlorides. Its interactions with the Pd center boost electron density, forcing oxidative addition even on electron-rich rings.
- Base Switch: Switch from Carbonates () to (anhydrous) or

- Why: Higher solubility in dioxane/water mixes and better activation of the boronic acid.
- Solvent System: 1,4-Dioxane : Water (4:1) at 100°C. The water is non-negotiable; it is required for the transmetallation step involving the boronate species.

Q2: I see significant hydrodechlorination (reduction of Cl to H). How do I stop this?

Diagnosis: This is a side reaction where the Pd-hydride species (formed via

-hydride elimination from solvents or ligands) reduces your starting material. Fix:

- Solvent Purity: Ensure dioxane is peroxide-free and anhydrous (before water addition).
- Concentration: Run the reaction at high concentration (0.5 M to 1.0 M). Dilute conditions favor side reactions.
- Scavenger: Add 5 mol% 2,6-di-tert-butyl-4-methylphenol (BHT). It scavenges radical intermediates that often plague electron-rich heterocyclic couplings.

Module 2: Coupling at the C4-Amine (Buchwald-Hartwig)

Objective: N-Arylation (using the molecule as a nucleophile).

Q3: The amine won't couple to aryl halides. I mostly recover starting material.

Diagnosis: The 3-methoxy group creates a "picket fence" around the 4-amino group, preventing the Pd-Aryl complex from approaching. Additionally, the 4-amino group is electronically coupled to the pyridine ring, reducing its nucleophilicity (pKa is lower than aniline).

The Solution: The "BrettPhos" System For sterically hindered primary amines, BrettPhos or tBuBrettPhos are the gold standards.

- Ligand: BrettPhos (for aryl bromides/iodides) or tBuBrettPhos (for aryl chlorides).

- Pre-catalyst: Use BrettPhos Pd G3.[1]
 - Crucial: Do NOT generate the catalyst in situ from

if possible. The induction period allows the free amine to poison the Pd(II) source. G3 precatalysts activate immediately upon base exposure.
- Base:

(Lithium Hexamethyldisilazide).
 - Why: Weak bases (

) often fail with electron-deficient anilines. LHMDS irreversibly deprotonates the amine, creating a potent amide nucleophile that overcomes the steric barrier.

Module 3: Strategic Visualization

Workflow Decision Tree

The following diagram illustrates the critical decision pathways for selecting the correct conditions based on your specific failure mode.

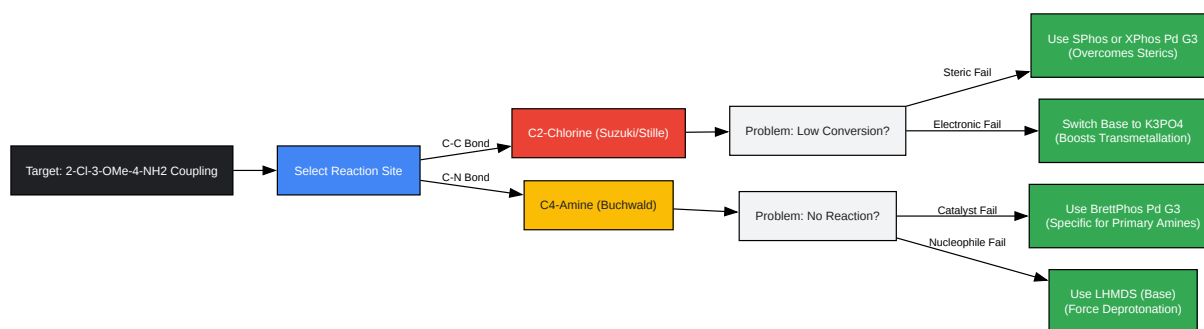

[Click to download full resolution via product page](#)

Caption: Decision matrix for selecting catalyst/base combinations based on reaction site and failure mode.

Module 4: Validated Experimental Protocols

Protocol A: High-Yield Suzuki Coupling (C2-Arylation)

Use this for coupling the 2-Cl with Boronic Acids.

Reagents:

- Substrate: 2-Chloro-3-methoxy-4-pyridinamine (1.0 equiv)
- Boronic Acid: Aryl-B(OH)₂ (1.5 equiv)
- Catalyst: XPhos Pd G3 (2–5 mol%)
- Base:

(3.0 equiv, finely ground)
- Solvent: 1,4-Dioxane / Water (4:1 ratio, degassed)

Step-by-Step:

- Charge: Add substrate, boronic acid, base, and catalyst to a reaction vial equipped with a stir bar.
- Inert: Seal the vial and purge with Nitrogen/Argon for 5 minutes (balloon or manifold).
- Solvent: Add degassed Dioxane/Water via syringe.
- Heat: Place in a pre-heated block at 100°C. Stir vigorously (1000 rpm).
 - Tip: Fast stirring is critical for the biphasic mixture.
- Monitor: Check LCMS at 2 hours. If conversion <50%, add 1 mol% more catalyst.

- Workup: Cool to RT. Dilute with EtOAc. Filter through Celite.[2][3][4] Wash with Brine.[4]

Protocol B: Sterically Demanding Buchwald Amination (N-Arylation)

Use this for coupling the 4-NH₂ with Aryl Halides.

Reagents:

- Substrate: 2-Chloro-3-methoxy-4-pyridinamine (1.2 equiv)
- Coupling Partner: Aryl Bromide/Chloride (1.0 equiv)
- Catalyst: BrettPhos Pd G3 (2–5 mol%)
- Base:

(2.2 equiv, 1M in THF)

- Solvent: THF (anhydrous)

Step-by-Step:

- Charge: Add Substrate, Aryl Halide, and Catalyst to a dry vial. Purge with Argon.
- Solvent: Add anhydrous THF.
- Base Addition: Dropwise add LHMDS solution at Room Temperature. You may see a color change (deprotonation of amine).
- Heat: Heat to 65°C. (Do not overheat LHMDS reactions; they can degrade).
- Time: Run for 4–16 hours.
- Quench: Quench with saturated solution.

Module 5: Data & Comparison

Table 1: Catalyst Performance on 2-Chloro-3-methoxy-4-pyridinamine (Suzuki Coupling)

Catalyst System	Ligand Class	Yield (Isolated)	Notes
	Monodentate	< 15%	Fails due to poor oxidative addition; steric clash.
	Bidentate	25-35%	Better stability, but sluggish reaction rates.
+ SPhos	Dialkylbiaryl	88%	Excellent steric tolerance; high turnover.
XPhos Pd G3	Pre-catalyst	92%	Fastest initiation; handles 3-OMe bulk best.

Table 2: Common Troubleshooting Codes

Observation	Root Cause	Immediate Action
Black Precipitate	Pd agglomeration (Pd-black)	Switch to G3 precatalyst; ensure inert atmosphere.
Starting Material Remaining	Catalyst poisoning by NH ₂	Protect NH ₂ (e.g., Boc) OR use higher catalyst load (5 mol%).
Product + De-Cl Product	Hydrodechlorination	Use anhydrous solvents; lower temp to 80°C; add BHT.

References

- Buchwald-Hartwig Amination Conditions & Catalyst Generations. Source: Sigma-Aldrich / MilliporeSigma Cross-Coupling Manual.

- Suzuki-Miyaura Coupling of Heteroaryl Chlorides.
 - Source: BenchChem Application Notes (Suzuki Coupling Protocols).[3]
- Optimization of 2-Pyridyl Nucleophiles and Electrophiles.
 - Source: National Institutes of Health (PMC) - A General Method for Suzuki-Miyaura Coupling of 2-Pyridyl Nucleophiles.
 - URL:[[Link](#)]
- Mechanistic Insight into Catalyst Poisoning by Aminopyridines. Source: WuXi AppTec - Chemical Insights on Buchwald-Hartwig Design.

Need Custom Synthesis?

BenchChem offers custom synthesis for rare earth carbides and specific isotopic labeling.

Email: info@benchchem.com or [Request Quote Online](#).

Sources

- [1. sigmaaldrich.com](https://www.sigmaaldrich.com) [[sigmaaldrich.com](https://www.sigmaaldrich.com)]
- [2. organic-synthesis.com](https://www.organic-synthesis.com) [[organic-synthesis.com](https://www.organic-synthesis.com)]
- [3. benchchem.com](https://www.benchchem.com) [[benchchem.com](https://www.benchchem.com)]
- [4. pdf.benchchem.com](https://pdf.benchchem.com) [pdf.benchchem.com]
- To cite this document: BenchChem. [Technical Support Center: Optimizing 2-Chloro-3-methoxy-4-pyridinamine Couplings]. BenchChem, [2026]. [Online PDF]. Available at: [<https://www.benchchem.com/product/b8139761/docs#technical-support-center-optimizing-2-chloro-3-methoxy-4-pyridinamine-couplings>]

Disclaimer & Data Validity:

The information provided in this document is for Research Use Only (RUO) and is strictly not intended for diagnostic or therapeutic procedures. While BenchChem strives to provide

accurate protocols, we make no warranties, express or implied, regarding the fitness of this product for every specific experimental setup.

Technical Support: The protocols provided are for reference purposes. Unsure if this reagent suits your experiment?

Need Industrial/Bulk Grade? [Request Custom Synthesis Quote](#)

BenchChem

Our mission is to be the trusted global source of essential and advanced chemicals, empowering scientists and researchers to drive progress in science and industry.

Contact

Address: 3281 E Guasti Rd
Ontario, CA 91761, United States
Phone: (601) 213-4426
Email: info@benchchem.com

[Contact our Ph.D. Support Team for a compatibility check](#)