

# Technical Support Center: Enhancing TAK-615 Performance in Functional Assays

**Author:** BenchChem Technical Support Team. **Date:** April 2026

## Compound of Interest

Compound Name: TAK-615  
Cat. No.: B8134370

[Get Quote](#)

This technical support center provides troubleshooting guides and frequently asked questions (FAQs) to help researchers, scientists, and drug development professionals optimize the performance of **TAK-615** in functional assays.

## Frequently Asked Questions (FAQs)

Q1: What is **TAK-615** and what is its mechanism of action?

A1: **TAK-615** is a negative allosteric modulator (NAM) of the Lysophosphatidic Acid Receptor 1 (LPA1).<sup>[1][2][3]</sup> As a NAM, it binds to a site on the receptor that is different from the orthosteric site where the endogenous ligand, lysophosphatidic acid (LPA), binds. This binding modulates the receptor's response to LPA, typically by reducing the maximal effect or potency of the agonist. **TAK-615** has been shown to have a distinct inhibitory profile across various LPA1-mediated signaling pathways.<sup>[4][5]</sup>

Q2: In which functional assays can **TAK-615** be evaluated?

A2: The activity of **TAK-615** on the LPA1 receptor can be assessed in a variety of functional assays that measure different aspects of the receptor's signaling cascade. These include:

- Calcium Mobilization Assays: To measure Gαq-mediated signaling.
- cAMP Assays: To measure Gαi-mediated signaling.
- β-Arrestin Recruitment Assays: To measure β-arrestin engagement with the receptor.
- GTPγS Binding Assays: To measure G protein activation.
- RhoA Activation Assays: To measure Gα12/13-mediated signaling.[4][5]

Q3: What is the expected outcome when using **TAK-615** in these assays?

A3: **TAK-615** is a negative allosteric modulator and is expected to decrease the LPA-induced signal in these functional assays. It is important to note that **TAK-615** may exhibit pathway-biased antagonism, meaning it may inhibit some signaling pathways more effectively than others.[4][5] For instance, studies have shown that **TAK-615** significantly inhibits Gα12/13 signaling (measured by RhoA activation) but has a more partial inhibitory effect on Gαq (measured by calcium mobilization) and β-arrestin recruitment, with little to no effect on Gαi signaling (measured by cAMP assays).

## Troubleshooting Guides

### General Troubleshooting

Problem: No inhibitory effect of **TAK-615** is observed.

Possible Cause	Troubleshooting Steps
Incorrect TAK-615 Concentration	Ensure the concentration range of TAK-615 is appropriate. As a NAM, its effect may be more pronounced at higher concentrations of the orthosteric agonist (LPA). Perform a dose-response experiment with varying concentrations of both TAK-615 and LPA.
Low LPA (Agonist) Concentration	The inhibitory effect of a NAM is often dependent on the presence of an agonist. Ensure you are using a concentration of LPA that elicits a submaximal to maximal response (e.g., EC50 to EC80) in your assay system.
Cell Health and Passage Number	Use healthy, actively dividing cells. High passage numbers can lead to changes in receptor expression and signaling. It is recommended to use cells within a consistent and low passage number range.[6]
Inappropriate Assay Window	The signal-to-background ratio of your assay may be too low to detect the inhibitory effect of TAK-615. Optimize assay conditions (e.g., cell density, incubation times, reagent concentrations) to maximize the assay window.
TAK-615 Solubility Issues	TAK-615 is typically dissolved in DMSO.[3] Ensure that the final DMSO concentration in your assay is consistent across all wells and is at a level that does not affect cell viability or assay performance (typically $\leq 1\%$ ).[7] If solubility is a concern, sonication may be recommended.[3]

## Assay-Specific Troubleshooting

Problem: High background or variable fluorescence signal.

Possible Cause	Troubleshooting Steps
Uneven Cell Plating	Ensure a uniform, confluent monolayer of cells on the day of the assay. Inconsistent cell numbers will lead to variability in the fluorescence signal. <a href="#">[8]</a>
Incomplete Dye Loading or Leakage	Optimize dye loading incubation time and temperature. <a href="#">[8]</a> Some cell lines may require the use of an anion transport inhibitor like probenecid to retain the calcium-sensitive dye. <a href="#">[9]</a>
Autofluorescence of Compounds	Test TAK-615 and any other compounds for autofluorescence at the excitation and emission wavelengths of your calcium indicator dye.

Problem: Inconsistent or no change in cAMP levels with Gai-coupled receptor activation.

Possible Cause	Troubleshooting Steps
Suboptimal Forskolin Concentration	For Gai-coupled receptors, the assay typically involves stimulating adenylyl cyclase with forskolin to generate a cAMP signal, which is then inhibited by the Gai-activating agonist. The concentration of forskolin needs to be optimized to create a sufficient signal window to observe inhibition. <a href="#">[10]</a>
Phosphodiesterase (PDE) Activity	High PDE activity can rapidly degrade cAMP, masking the effects of your compounds. Include a PDE inhibitor, such as IBMX, in your assay buffer to allow for cAMP accumulation. <a href="#">[11]</a>
Low Receptor Expression	If the LPA1 receptor is transiently expressed, ensure transfection efficiency is high and consistent.

Problem: Low signal-to-background ratio.

Possible Cause	Troubleshooting Steps
Suboptimal Cell Density	Both too low and too high cell densities can result in a poor assay window. Titrate the cell number to find the optimal density that provides the best signal-to-background ratio. <a href="#">[12]</a>
Incorrect Incubation Time	The kinetics of $\beta$ -arrestin recruitment can vary between receptors. Perform a time-course experiment to determine the optimal incubation time for the LPA1 receptor in your cell system. <a href="#">[6]</a>
Receptor- $\beta$ -Arrestin Fusion Protein Issues	If using a system with tagged proteins, ensure the fusion proteins are correctly expressed and functional. Test with a known potent LPA1 agonist to validate the assay system. <a href="#">[6]</a>

Problem: High basal GTPyS binding.

Possible Cause	Troubleshooting Steps
Constitutive Receptor Activity	Some GPCRs exhibit constitutive (agonist-independent) activity. The addition of GDP can help to reduce basal signaling by favoring the inactive G protein state. <a href="#">[13]</a>
Membrane Preparation Quality	Use freshly prepared or properly stored (-80°C) cell membranes. Repeated freeze-thaw cycles can damage membrane integrity and increase non-specific binding. <a href="#">[14]</a>
Suboptimal Assay Buffer Conditions	The concentrations of Mg <sup>2+</sup> and NaCl in the assay buffer can significantly impact G protein activation and should be optimized. <a href="#">[14]</a> <a href="#">[15]</a>

Problem: No detectable active RhoA.

Possible Cause	Troubleshooting Steps
Rapid GTP Hydrolysis	Active GTP-bound RhoA is rapidly hydrolyzed to the inactive GDP-bound form. It is critical to work quickly and keep samples on ice throughout the procedure to minimize this.[16]
Insufficient Cell Lysis	Ensure complete cell lysis to release RhoA. If lysates are viscous due to nuclear lysis, they can be passed through a narrow-gauge syringe to shear genomic DNA.[17]
Low Levels of Activated RhoA	In vivo, only a small fraction of the total RhoA may be active at any given time. Ensure you are loading a sufficient amount of total protein for the pull-down assay.[18] Consider using a positive control, such as GTPyS loading, to confirm the assay is working.[17][19]

## Quantitative Data Summary

The following table summarizes the reported in vitro activity of **TAK-615** in various functional assays.

Assay	Parameter	Value	Cell System/Conditions	Reference
Binding Affinity	Kd (high affinity)	1.7 ± 0.5 nM	Membranes expressing human LPA1 receptor	[1]
	Kd (low affinity)	14.5 ± 12.1 nM	Membranes expressing human LPA1 receptor	[1]
β-Arrestin Assay	IC50	23 ± 13 nM	Not specified	[1]
% Inhibition	~40% at 10 μM	Not specified	[1]	
Calcium Mobilization	IC50	91 ± 30 nM	Not specified	[1]
% Inhibition	~60% at 10 μM	Not specified	[1]	
cAMP Assay	Effect	No observable effect	Not specified	
GTPγS Binding Assay	Effect	Not specified	Not specified	[4][5]
RhoA Activation Assay	Effect	Significant inhibition	Not specified	

## Experimental Protocols

Detailed methodologies for key experiments are provided below. These are general protocols and may require optimization for your specific cell line and experimental conditions.

### Calcium Mobilization Assay Protocol

- Cell Plating: Seed cells expressing the LPA1 receptor into a 96-well, black-walled, clear-bottom plate to achieve a confluent monolayer on the day of the assay.[8]

- **Dye Loading:** Remove the culture medium and add a calcium-sensitive fluorescent dye (e.g., Fluo-4 AM) prepared in an appropriate assay buffer. Incubate according to the dye manufacturer's instructions (e.g., 30-60 minutes at 37°C).[8] Probenecid may be included to prevent dye leakage.[9]
- **Compound Addition:** Add varying concentrations of **TAK-615** to the wells and incubate for a predetermined time.
- **Agonist Stimulation and Measurement:** Place the plate in a fluorescence plate reader (e.g., FLIPR or FlexStation).[9][20] Add LPA (agonist) to the wells and immediately begin measuring the fluorescence intensity over time.
- **Data Analysis:** The change in fluorescence intensity corresponds to the change in intracellular calcium concentration. Plot the response against the compound concentration to determine the IC50 of **TAK-615**.

## cAMP Assay Protocol (for G $\alpha$ -coupled receptors)

- **Cell Plating:** Plate cells in a suitable microplate and incubate to allow for attachment and recovery.
- **Compound Incubation:** Treat the cells with different concentrations of **TAK-615** for a specified period.
- **Stimulation:** Add a fixed concentration of forskolin (to stimulate cAMP production) along with the LPA agonist.
- **Cell Lysis and Detection:** Lyse the cells and measure the intracellular cAMP levels using a commercially available kit (e.g., HTRF, luminescence, or fluorescence polarization-based assays).[10][21][22][23]
- **Data Analysis:** Generate a dose-response curve by plotting the inhibition of the forskolin-stimulated cAMP signal against the concentration of **TAK-615** to calculate the IC50.

## $\beta$ -Arrestin Recruitment Assay Protocol (Example using PathHunter®)

- Cell Plating: Plate PathHunter® cells expressing the LPA1 receptor-ProLink fusion and the  $\beta$ -arrestin-Enzyme Acceptor fusion in a white-walled, clear-bottom microplate.[6][7]
- Compound Addition: Add **TAK-615** at various concentrations to the wells.
- Agonist Stimulation: Add the LPA agonist at a concentration that gives a robust signal (e.g., EC80) and incubate for the optimized time (e.g., 60-90 minutes) at 37°C.[6]
- Detection: Add the detection reagent containing the chemiluminescent substrate and incubate at room temperature to allow for signal development.[6]
- Measurement: Read the chemiluminescent signal using a plate luminometer.
- Data Analysis: Calculate the percent inhibition of the agonist-induced signal at each concentration of **TAK-615** and fit the data to a dose-response curve to determine the IC50.

## GTPyS Binding Assay Protocol

- Membrane Preparation: Prepare cell membranes from cells overexpressing the LPA1 receptor.[13]
- Assay Setup: In a microplate, combine the cell membranes, **TAK-615** at various concentrations, and the LPA agonist in an assay buffer containing GDP.[13][24]
- Initiate Reaction: Add [35S]GTPyS to initiate the binding reaction and incubate at 30°C.[13]
- Termination and Separation: Terminate the reaction by rapid filtration through a filter plate to separate the membrane-bound from free [35S]GTPyS.[24]
- Detection: Measure the radioactivity retained on the filter using a scintillation counter.
- Data Analysis: Determine the specific binding and plot the inhibition of agonist-stimulated [35S]GTPyS binding against the **TAK-615** concentration.

## RhoA Activation Assay Protocol (Pull-down based)

- Cell Culture and Stimulation: Culture cells to near confluence, serum-starve if necessary, and then stimulate with LPA in the presence or absence of **TAK-615** for a short period.

- Cell Lysis: Immediately lyse the cells in an ice-cold lysis buffer containing protease inhibitors. [\[18\]](#)[\[19\]](#)
- Pull-down of Active RhoA: Incubate the cell lysates with Rhotekin-RBD agarose beads (or other affinity matrix for active RhoA) to selectively pull down GTP-bound RhoA. [\[17\]](#)[\[19\]](#)
- Washing: Wash the beads to remove non-specifically bound proteins.
- Elution and Western Blotting: Elute the bound proteins from the beads and separate them by SDS-PAGE. Transfer the proteins to a membrane and probe with an anti-RhoA antibody to detect the amount of activated RhoA. Also, run a western blot for total RhoA from the initial cell lysates as a loading control.
- Data Analysis: Quantify the band intensities and express the amount of active RhoA as a fraction of total RhoA.

## Visualizations

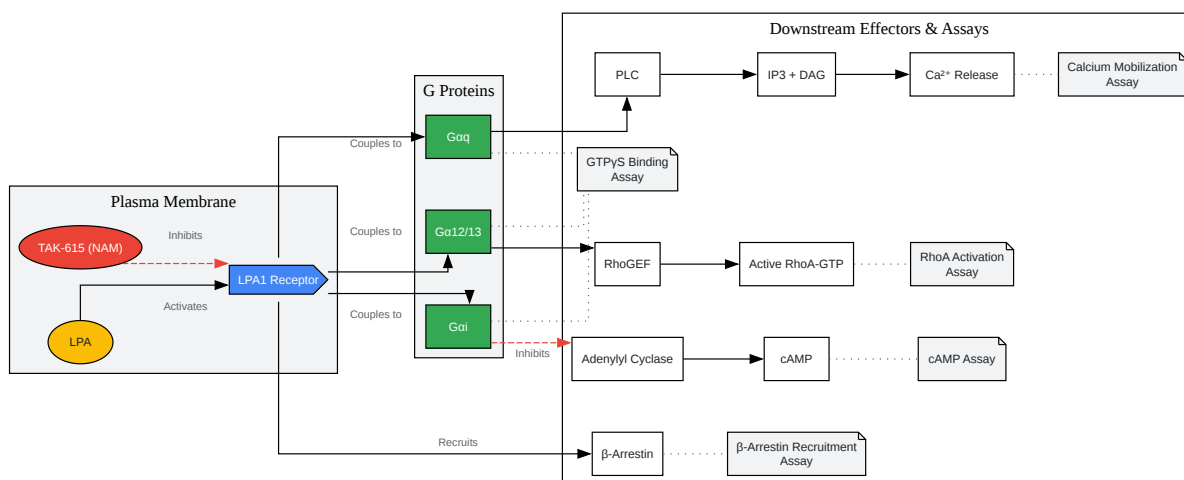

[Click to download full resolution via product page](#)

Caption: LPA1 receptor signaling pathways and corresponding functional assays.

Caption: A logical workflow for troubleshooting unexpected results with **TAK-615**.

### Need Custom Synthesis?

BenchChem offers custom synthesis for rare earth carbides and specific isotopic labeling.

Email: [info@benchchem.com](mailto:info@benchchem.com) or [Request Quote Online](#).

## References

- [1. medchemexpress.com \[medchemexpress.com\]](https://www.medchemexpress.com)
- [2. TAK-615 | LPA Receptor | Ambeed.com \[ambeed.com\]](https://www.ambeed.com)
- [3. TAK-615 | LPA Receptor | TargetMol \[targetmol.com\]](https://www.targetmol.com)
- [4. Identification of compounds acting as negative allosteric modulators of the LPA1 receptor - PubMed \[pubmed.ncbi.nlm.nih.gov\]](https://pubmed.ncbi.nlm.nih.gov)
- [5. researchgate.net \[researchgate.net\]](https://www.researchgate.net)
- [6. Measurement of  \$\beta\$ -Arrestin Recruitment for GPCR Targets - Assay Guidance Manual - NCBI Bookshelf \[ncbi.nlm.nih.gov\]](https://www.ncbi.nlm.nih.gov)
- [7. cosmobio.co.jp \[cosmobio.co.jp\]](https://www.cosmobio.co.jp)
- [8. Calcium Mobilization Assay to Measure the Activity of Gq-coupled Receptors \[bio-protocol.org\]](https://www.bioprotocol.org)
- [9. Calcium Mobilization Assay to Measure the Activity of Gq-coupled Receptors \[en.bioprotocol.org\]](https://www.bioprotocol.org)
- [10. Measurement of cAMP for Gas- and Gai Protein-Coupled Receptors \(GPCRs\) - Assay Guidance Manual - NCBI Bookshelf \[ncbi.nlm.nih.gov\]](https://www.ncbi.nlm.nih.gov)
- [11. revvity.com \[revvity.com\]](https://www.revivity.com)
- [12. resources.revvity.com \[resources.revvity.com\]](https://resources.revivity.com)
- [13. Measuring G-protein-coupled Receptor Signaling via Radio-labeled GTP Binding - PMC \[pmc.ncbi.nlm.nih.gov\]](https://pubmed.ncbi.nlm.nih.gov)
- [14. GTPyS Binding Assays - Assay Guidance Manual - NCBI Bookshelf \[ncbi.nlm.nih.gov\]](https://www.ncbi.nlm.nih.gov)
- [15. GTPyS Binding Assays - PubMed \[pubmed.ncbi.nlm.nih.gov\]](https://pubmed.ncbi.nlm.nih.gov)
- [16. researchgate.net \[researchgate.net\]](https://www.researchgate.net)
- [17. abcam.com \[abcam.com\]](https://www.abcam.com)
- [18. abcam.com \[abcam.com\]](https://www.abcam.com)
- [19. cellbiolabs.com \[cellbiolabs.com\]](https://www.cellbiolabs.com)
- [20. FLIPR Calcium Mobilization Assays in GPCR Drug Discovery | Springer Nature Experiments \[experiments.springernature.com\]](https://www.springer.com)
- [21. GloSensor™ cAMP Assay Protocol \[promega.com\]](https://www.promega.com)
- [22. cAMP-Glo™ Assay \[promega.com\]](https://www.promega.com)
- [23. m.youtube.com \[m.youtube.com\]](https://www.youtube.com)
- [24. GTPyS Binding Assay - Creative Bioarray \[dda.creative-bioarray.com\]](https://www.creative-bioarray.com)

- To cite this document: BenchChem. [Technical Support Center: Enhancing TAK-615 Performance in Functional Assays]. BenchChem, [2026]. [Online PDF]. Available at: [<https://www.benchchem.com/product/b8134370/docs#technical-support-center-enhancing-tak-615-performance-in-functional-assays>]

---

### Disclaimer & Data Validity:

The information provided in this document is for Research Use Only (RUO) and is strictly not intended for diagnostic or therapeutic procedures. While BenchChem strives to provide accurate protocols, we make no warranties, express or implied, regarding the fitness of this product for every specific experimental setup.

**Technical Support:** The protocols provided are for reference purposes. Unsure if this reagent suits your experiment?

**Need Industrial/Bulk Grade?** [Request Custom Synthesis Quote](#)

## BenchChem

Our mission is to be the trusted global source of essential and advanced chemicals, empowering scientists and researchers to drive progress in science and industry.

### Contact

Address: 3281 E Guasti Rd  
Ontario, CA 91761, United States  
Phone: (601) 213-4426  
Email: [info@benchchem.com](mailto:info@benchchem.com)

[Contact our Ph.D. Support Team for a compatibility check](#)