

# Application Note: DBCO-PEG4-Acid Linker for PROTAC Synthesis and Design

**Author:** BenchChem Technical Support Team. **Date:** April 2026

## Compound of Interest

Compound Name: *Dbco-NH-peg4-CH2CH2cooh*

CAS No.: *2110448-99-0*

Cat. No.: *B8133692*

[Get Quote](#)

## Abstract & Core Directive

This guide details the strategic application of DBCO-PEG4-acid (Dibenzocyclooctyne-PEG4-Carboxylic Acid) in the synthesis of Proteolysis Targeting Chimeras (PROTACs). Unlike traditional linear synthesis, this linker enables a modular "Click-to-Degrade" approach, facilitating the rapid generation of PROTAC libraries and in-cell assembly strategies (CLIPTAC). This document provides validated protocols for amide coupling and Strain-Promoted Azide-Alkyne Cycloaddition (SPAAC), underpinned by mechanistic rationale and troubleshooting frameworks.

## Chemical Logic & Rationale

The selection of DBCO-PEG4-acid is not arbitrary; it addresses specific physicochemical and kinetic challenges in PROTAC design.

## The Anatomy of the Linker

Component	Functionality	Mechanistic Advantage
DBCO (Dibenzocyclooctyne)	Bioorthogonal Handle	Enables Copper-Free Click Chemistry (SPAAC).[1][2] Unlike CuAAC, it requires no cytotoxic copper catalyst, preserving cell viability for in-cell assembly applications [1]. [3]
PEG4 (Tetraethylene Glycol)	Solubility & Spacer	Provides a defined length (~16 Å) that often sits in the "Goldilocks" zone for ternary complex formation. The hydrophilic ether oxygens offset the high lipophilicity of the DBCO ring and the warheads, improving thermodynamic solubility [2].
Carboxylic Acid (-COOH)	Chemical Handle	Standard attachment point for amine-containing ligands (POI or E3 binders) via robust amide coupling (HATU/EDC chemistry).

## Why PEG4?

In PROTAC design, linker length determines the spatial proximity of the E3 ligase and the Protein of Interest (POI).[4]

- Too Short: Steric clashes prevent ternary complex formation.
- Too Long: Entropic penalty reduces binding affinity (cooperativity < 1).
- PEG4: Empirical data suggests PEG4 is frequently the optimal starting length to balance flexibility and proximity for initial library screening [3].

## Strategic Design: The "Click-to-Degrade" Workflow

The primary utility of DBCO-PEG4-acid is the conversion of a standard ligand into a "Click-Ready" precursor. This allows researchers to synthesize a single batch of E3-ligase binder (e.g., Thalidomide-DBCO) and click it with dozens of different POI ligands (e.g., Kinase Inhibitor-Azide).

### Workflow Visualization

The following diagram illustrates the modular assembly of a PROTAC library using DBCO-PEG4-acid.

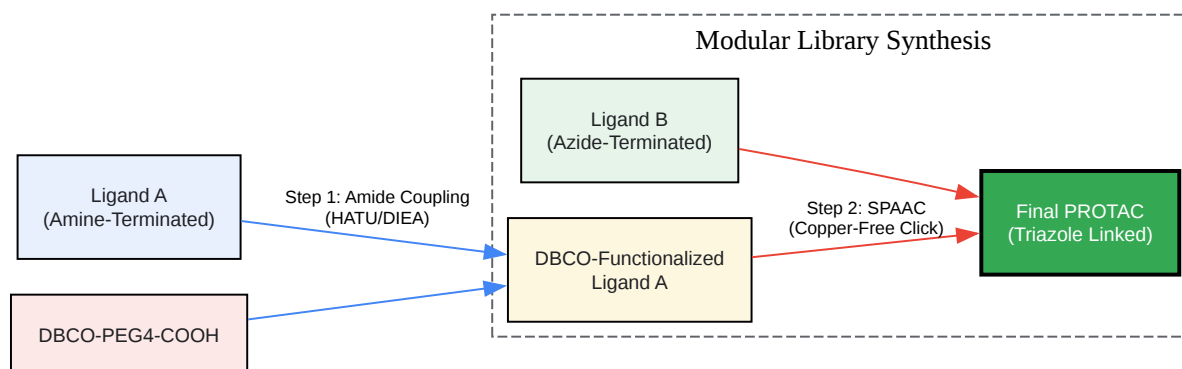

[Click to download full resolution via product page](#)

Caption: Modular synthesis workflow. Step 1 functionalizes the amine-ligand with the DBCO linker.<sup>[5]</sup> Step 2 utilizes SPAAC to couple with an azide-partner, forming the active PROTAC.

## Validated Experimental Protocols

### Protocol 1: Amide Coupling (Synthesis of DBCO-Ligand)

Objective: Attach DBCO-PEG4-acid to an amine-containing ligand (e.g., Pomalidomide-NH<sub>2</sub> or VHL-NH<sub>2</sub>). Chemistry: HATU-mediated activation.<sup>[6]</sup>

Materials:

- DBCO-PEG4-acid (1.0 equiv)[7]
- Amine-Ligand (1.0 - 1.2 equiv)
- HATU (1.1 equiv)
- DIEA (N,N-Diisopropylethylamine) (3.0 equiv)
- Anhydrous DMF or DMSO

#### Step-by-Step Procedure:

- Preparation: Dissolve DBCO-PEG4-acid in anhydrous DMF to a concentration of 0.1 M.
- Activation: Add HATU (1.1 equiv) and DIEA (3.0 equiv) to the DBCO-PEG4-acid solution. Stir at Room Temperature (RT) for 5–10 minutes. Note: The solution may turn slightly yellow.
- Coupling: Add the Amine-Ligand (1.0 equiv) dissolved in minimal DMF.
- Incubation: Stir the reaction under nitrogen atmosphere at RT for 1–2 hours.
  - QC Check: Monitor by LC-MS. Look for the disappearance of the amine mass and appearance of [Product + H]<sup>+</sup>.
- Work-up:
  - Option A (Precipitation): If the product is hydrophobic, add 10x volume of ice-cold water or ether to precipitate. Centrifuge and wash.
  - Option B (Direct Prep-HPLC): For PROTAC precursors, direct injection onto C18 Reverse Phase HPLC is recommended to ensure high purity (>95%). Use a water/acetonitrile gradient with 0.1% Formic Acid. Avoid TFA if possible, as strong acids can degrade the DBCO moiety over time [4].

## Protocol 2: PROTAC Assembly via SPAAC (Click Reaction)

Objective: Conjugate DBCO-Ligand with Azide-Ligand. Chemistry: Strain-Promoted Azide-Alkyne Cycloaddition (SPAAC).<sup>[2][8][9][10][11][12]</sup>

Materials:

- DBCO-Functionalized Ligand (from Protocol 1)<sup>[5][12]</sup>
- Azide-Functionalized Partner (e.g., Target Protein Ligand-N<sub>3</sub>)
- Solvent: DMSO, DMF, or MeOH (for synthesis); PBS/DMSO mix (for biological applications).

Step-by-Step Procedure:

- Stoichiometry: Mix DBCO-Ligand and Azide-Ligand in a 1:1 molar ratio.
  - Expert Tip: If one ligand is significantly more valuable/scarce, use it as the limiting reagent (1.0 equiv) and use a slight excess (1.2 equiv) of the cheaper partner to drive completion.
- Reaction: Incubate at Room Temperature.
  - Solvent: For preparative synthesis, use minimal DMSO or DMF (concentration ~10–50 mM).
  - Time: Reaction is typically complete within 1–4 hours.
- Monitoring: Monitor by LC-MS. The DBCO absorbance peak (approx. 309 nm) will decrease/shift as the triazole forms.
- Purification: Purify the final PROTAC using Prep-HPLC (C18 column).
  - Lyophilization: Freeze-dry the collected fractions to obtain the PROTAC powder.

## Quality Control & Characterization

Method	Specification	Note
LC-MS	M+H or M+Na peak	Essential. Check for absence of unreacted Azide or DBCO starting materials.[2][5]
<sup>1</sup> H NMR	Triazole Proton	The formation of the triazole ring often yields a distinct singlet peak in the aromatic region (~7.5 - 8.5 ppm), though it may be obscured in complex PROTACs.
Solubility	Visual Inspection	DBCO is lipophilic. Ensure the final PROTAC redissolves in the assay buffer (often requires <1% DMSO).

## Troubleshooting Guide

### Issue: Precipitation during Click Reaction

- Cause: The intermediate triazole product or the DBCO-ligand is too hydrophobic.
- Solution: Increase the percentage of organic co-solvent (DMSO/DMF) during the reaction. Alternatively, switch to a longer PEG linker (e.g., DBCO-PEG6-acid) to improve solubility.

### Issue: Incomplete Coupling (Protocol 1)

- Cause: Steric hindrance on the amine ligand or deactivated carboxylic acid.
- Solution: Switch coupling reagents. Try PyBOP or COMU instead of HATU. Ensure the DMF is anhydrous (water hydrolyzes activated esters).

### Issue: Degradation of DBCO

- Cause: Exposure to free thiols (e.g., DTT, mercaptoethanol) or strong acids.

- Solution: DBCO can react with free thiols (thiol-yne reaction). Ensure buffers are free of DTT.  
[5] Avoid storing DBCO compounds in TFA-containing solvents for extended periods [5].

## References

### Need Custom Synthesis?

BenchChem offers custom synthesis for rare earth carbides and specific isotopic labeling.

Email: [info@benchchem.com](mailto:info@benchchem.com) or [Request Quote Online](#).

## Sources

- 1. [pdf.benchchem.com](https://pdf.benchchem.com) [[pdf.benchchem.com](https://pdf.benchchem.com)]
- 2. [pdf.benchchem.com](https://pdf.benchchem.com) [[pdf.benchchem.com](https://pdf.benchchem.com)]
- 3. [vectorlabs.com](https://vectorlabs.com) [[vectorlabs.com](https://vectorlabs.com)]
- 4. [chempep.com](https://chempep.com) [[chempep.com](https://chempep.com)]
- 5. [documents.thermofisher.com](https://documents.thermofisher.com) [[documents.thermofisher.com](https://documents.thermofisher.com)]
- 6. DBCO-PEG4-acid, 1537170-85-6 | BroadPharm [[broadpharm.com](https://broadpharm.com)]
- 7. [pdf.benchchem.com](https://pdf.benchchem.com) [[pdf.benchchem.com](https://pdf.benchchem.com)]
- 8. [medchemexpress.com](https://medchemexpress.com) [[medchemexpress.com](https://medchemexpress.com)]
- 9. [medchemexpress.com](https://medchemexpress.com) [[medchemexpress.com](https://medchemexpress.com)]
- 10. [medchemexpress.com](https://medchemexpress.com) [[medchemexpress.com](https://medchemexpress.com)]
- 11. [medchemexpress.com](https://medchemexpress.com) [[medchemexpress.com](https://medchemexpress.com)]
- 12. [docs.aatbio.com](https://docs.aatbio.com) [[docs.aatbio.com](https://docs.aatbio.com)]
- To cite this document: BenchChem. [Application Note: DBCO-PEG4-Acid Linker for PROTAC Synthesis and Design]. BenchChem, [2026]. [Online PDF]. Available at: [<https://www.benchchem.com/product/b8133692/docs#application-note-dbc0-peg4-acid-linker-for-protac-synthesis-and-design>]

---

### Disclaimer & Data Validity:

The information provided in this document is for Research Use Only (RUO) and is strictly not intended for diagnostic or therapeutic procedures. While BenchChem strives to provide accurate protocols, we make no warranties, express or implied, regarding the fitness of this product for every specific experimental setup.

**Technical Support:** The protocols provided are for reference purposes. Unsure if this reagent suits your experiment?

**Need Industrial/Bulk Grade?** [Request Custom Synthesis Quote](#)

## BenchChem

Our mission is to be the trusted global source of essential and advanced chemicals, empowering scientists and researchers to drive progress in science and industry.

### Contact

Address: 3281 E Guasti Rd  
Ontario, CA 91761, United States  
Phone: (601) 213-4426  
Email: [info@benchchem.com](mailto:info@benchchem.com)

[Contact our Ph.D. Support Team for a compatibility check](#)