

# Comparative Guide: Ionization Strategies and Fragmentation Dynamics of C<sub>16</sub>H<sub>16</sub>Br<sub>2</sub>

**Author:** BenchChem Technical Support Team. **Date:** April 2026

## Compound of Interest

Compound Name: 2,3-Dibromo-1,4-diphenylbutane

Cat. No.: B8122813

[Get Quote](#)

## Executive Summary

C<sub>16</sub>H<sub>16</sub>Br<sub>2</sub> represents a class of halogenated organic molecules often encountered in drug synthesis as intermediates (e.g., 2,3-dibromo-2,3-diphenylbutane or ring-substituted bis(bromomethyl) derivatives). For researchers, this molecule presents a specific analytical paradox: its high lipophilicity suggests Gas Chromatography (GC) as the separation method of choice, yet its thermally labile carbon-bromine (C-Br) bonds make it prone to degradation before ionization occurs.

This guide objectively compares Electron Ionization (EI)—the industry standard for fingerprinting—against Atmospheric Pressure Chemical Ionization (APCI), a softer alternative that preserves molecular integrity.<sup>[1]</sup> We provide experimental protocols to distinguish between in-source fragmentation and thermal degradation, a critical distinction for validating synthesis purity.

## Part 1: The Isotopic Fingerprint (The 1:2:1 Triad)

Before analyzing fragmentation, one must validate the molecular ion identity using the unique isotopic signature of bromine. Unlike chlorine (3:1 ratio), naturally occurring bromine exists as

(50.7%) and

(49.3%) in a nearly 1:1 ratio.

For a dibromo-compound (Br

), the statistical distribution follows a binomial expansion

, resulting in a 1:2:1 intensity ratio for the molecular ion cluster.

## Calculated Isotope Cluster for C<sub>16</sub>H<sub>16</sub>Br<sub>2</sub>

- Monoisotopic Mass (

):

≈ 366 Da

- :

≈ 368 Da

- :

≈ 370 Da

## Visualization: Isotope Distribution Logic

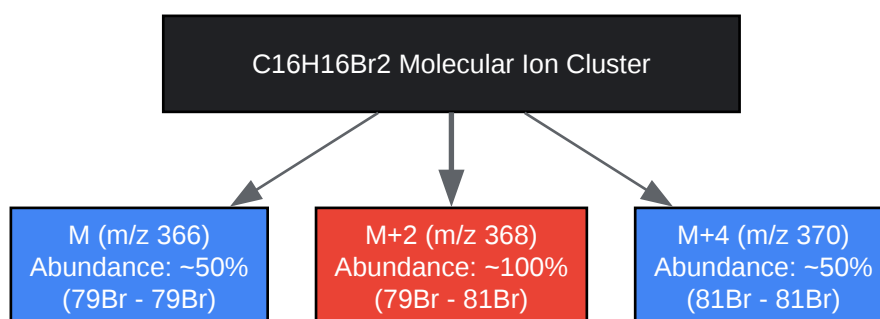

[Click to download full resolution via product page](#)

Caption: The theoretical 1:2:1 isotopic distribution pattern for a dibrominated species. The M+2 peak is the base peak of the cluster due to the statistical probability of the mixed isotope pairing.

## Part 2: Performance Comparison (EI vs. APCI)

For C<sub>16</sub>H<sub>16</sub>Br<sub>2</sub>, the choice of ionization source dictates whether you see the molecule or its decomposition products.

Feature	Electron Ionization (EI)	APCI (Atmospheric Pressure Chemical Ionization)
Energy Level	Hard (70 eV). High internal energy transfer.	Soft. Gas-phase chemical reactions.
Molecular Ion ( )	Often weak or absent. C-Br bonds cleave rapidly.	Dominant. Usually observed as or .
Primary Artifact	Thermal Degradation: Injector heat (250°C+) causes elimination of Br or HBr before the MS.	Minimal thermal stress. Desolvation occurs at lower effective temperatures.
Structural Data	Excellent for "fingerprinting" (tropylium ions, phenyl fragments).	Poor fragmentation. Requires MS/MS (CID) for structural elucidation.
Best Use Case	Library matching; identifying stable degradation products.	Confirming molecular weight and purity of the intact dibromide.

### Critical Insight: The "Phantom" Peak

In GC-MS (EI), a common error is misidentifying the peak at m/z 206-208 (dimethyl-stilbene derivative) as the parent. This is often a pyrolysis product formed in the injector liner via the elimination of Br

, not a mass spec fragment.

## Part 3: Fragmentation Dynamics (Mechanistic Pathways)

The fragmentation of  $C_{16}H_{16}Br_2$  (assuming a vicinal dibromide structure like 2,3-dibromo-2,3-diphenylbutane) follows three distinct pathways.

### Pathway A: Homolytic Cleavage (Radical Loss)

The weakest bond is C-Br. The molecular ion (

) ejects a bromine radical (

), leaving a cation.

- (1:1 ratio)

### Pathway B: Dehydrohalogenation (HBr Elimination)

Common in EI, the molecule loses HBr neutral species.

- Note: If this happens thermally in the injector, you will see the alkene parent ion, not the dibromide fragments.

### Pathway C: Benzylic/Backbone Cleavage

The central C-C bond is strained by the two phenyl and two methyl groups (in the butane derivative case).

- Cleavage yields a Cumyl-type cation ( $Ph-C(Me)-Br$ )

## Visualization: Fragmentation Tree

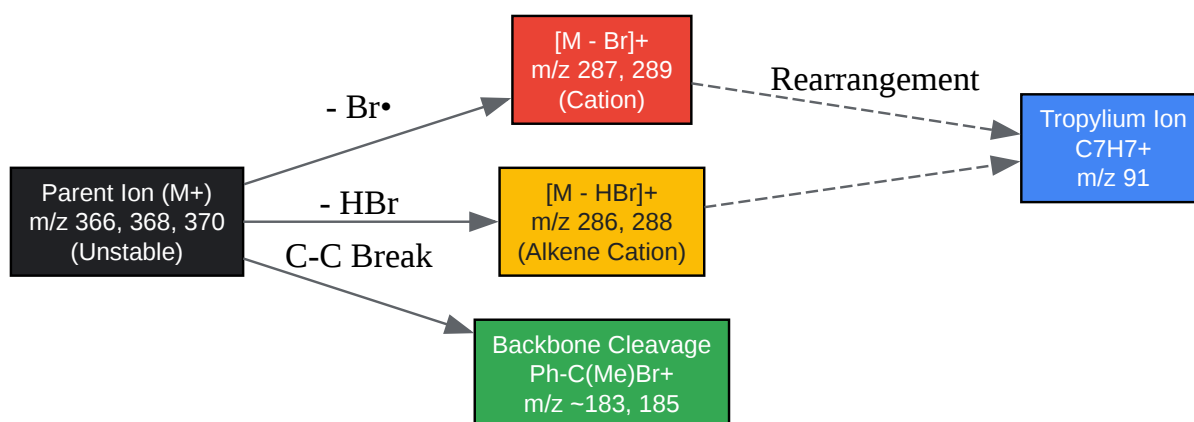

[Click to download full resolution via product page](#)

Caption: Primary fragmentation pathways for C<sub>16</sub>H<sub>16</sub>Br<sub>2</sub> under 70 eV EI. Note that the Tropylium ion (m/z 91) is a terminal fragment for most aromatic hydrocarbons.

## Part 4: Experimental Protocols

To ensure data integrity, use the following self-validating protocols.

### Protocol 1: "Cold" GC-MS (Minimizing Thermal Degradation)

Purpose: To distinguish between thermal elimination in the injector and actual EI fragmentation.

- Inlet Configuration: Use a Programmable Temperature Vaporizing (PTV) inlet or Cold On-Column injection.
- Temperature Ramp:
  - Start Inlet: 40°C (hold 0.5 min).
  - Ramp: 700°C/min to 250°C (after sample is on the column).
- Column: Non-polar (e.g., DB-5ms), 30m x 0.25mm.
- Validation: Inject a standard of the de-brominated alkene (e.g., dimethylstilbene). If your "Cold" run of C<sub>16</sub>H<sub>16</sub>Br<sub>2</sub> shows peaks distinct from the alkene standard, you have

successfully preserved the dibromide.

## Protocol 2: APCI-LC-MS (Molecular Weight Confirmation)

Purpose: To confirm the intact mass (M+2 peak at 368) without fragmentation.

- Solvent: Methanol/Water (80:20) with 0.1% Formic Acid. (Avoid Ammonium buffers which may suppress ionization for halides).
- Source Settings:
  - Mode: Positive (+).[\[2\]](#)
  - Corona Current: 4-5  $\mu$ A.
  - Vaporizer Temp: 300°C (High enough to desolvate, but rapid flow prevents degradation).
  - Cone Voltage: Low (15-20V) to prevent in-source CID.
- Data Check: Look for the cluster at 367/369/371. If the signal is weak, switch to Negative Mode APCI to look for adducts or bromide attachment, common in halogenated analysis.

## References

- NIST Mass Spectrometry Data Center. 1,2-Dibromo-1,2-diphenylethane Mass Spectrum. NIST Chemistry WebBook, SRD 69. Available at: [\[Link\]](#)
- McLafferty, F. W., & Tureček, F. (1993). Interpretation of Mass Spectra. University Science Books.
- Kostianen, R., & Kauppila, T. J. (2009). Effect of eluent on the ionization efficiency of nonpolar compounds in atmospheric pressure photoionization and chemical ionization. Journal of Chromatography A. [\[Link\]](#)

- Gross, J. H. (2017). Mass Spectrometry: A Textbook. Springer.

#### Need Custom Synthesis?

BenchChem offers custom synthesis for rare earth carbides and specific isotopic labeling.

Email: [info@benchchem.com](mailto:info@benchchem.com) or [Request Quote Online](#).

## Sources

- [1. researchgate.net \[researchgate.net\]](https://www.researchgate.net)
- [2. Identification and quantitation of lipid C=C location isomers: A shotgun lipidomics approach enabled by photochemical reaction - PMC \[pmc.ncbi.nlm.nih.gov\]](https://pubmed.ncbi.nlm.nih.gov/)
- To cite this document: BenchChem. [Comparative Guide: Ionization Strategies and Fragmentation Dynamics of C<sub>16</sub>H<sub>16</sub>Br<sub>2</sub>]. BenchChem, [2026]. [Online PDF]. Available at: [<https://www.benchchem.com/product/b8122813/docs#comparative-guide-ionization-strategies-and-fragmentation-dynamics-of-c16h16br2>]

---

#### Disclaimer & Data Validity:

The information provided in this document is for Research Use Only (RUO) and is strictly not intended for diagnostic or therapeutic procedures. While BenchChem strives to provide accurate protocols, we make no warranties, express or implied, regarding the fitness of this product for every specific experimental setup.

**Technical Support:** The protocols provided are for reference purposes. Unsure if this reagent suits your experiment?

**Need Industrial/Bulk Grade?** [Request Custom Synthesis Quote](#)

# BenchChem

Our mission is to be the trusted global source of essential and advanced chemicals, empowering scientists and researchers to drive progress in science and industry.

## Contact

Address: 3281 E Guasti Rd

Ontario, CA 91761, United States

Phone: (601) 213-4426

Email: [info@benchchem.com](mailto:info@benchchem.com)

[Contact our Ph.D. Support Team for a compatibility check](#)