

Optimizing JC-171 Concentration for Assays: A Technical Support Guide

Author: BenchChem Technical Support Team. **Date:** April 2026

Compound of Interest

Compound Name: JC-171
Cat. No.: B8117439

[Get Quote](#)

This technical support center provides researchers, scientists, and drug development professionals with comprehensive troubleshooting guides and frequently asked questions (FAQs) for optimizing the use of **JC-171** in various assays. **JC-171** is a selective inhibitor of the NLRP3 inflammasome, a key component of the innate immune system implicated in a wide range of inflammatory diseases. Proper concentration optimization is critical for obtaining accurate and reproducible experimental results.

Frequently Asked Questions (FAQs)

Q1: What is the mechanism of action of **JC-171**?

A1: **JC-171** is a selective, small-molecule inhibitor of the NLRP3 inflammasome. It directly targets the NLRP3 protein, interfering with the interaction between NLRP3 and ASC (Apoptosis-associated speck-like protein containing a CARD). This disruption prevents the assembly of the NLRP3 inflammasome complex, thereby inhibiting the activation of caspase-1 and the subsequent maturation and release of the pro-inflammatory cytokines interleukin-1 β (IL-1 β) and interleukin-18 (IL-18).

Q2: What is the recommended starting concentration for **JC-171** in in vitro assays?

A2: A good starting point for in vitro assays is the half-maximal inhibitory concentration (IC₅₀). For **JC-171**, the reported IC₅₀ for the inhibition of LPS/ATP-induced IL-1 β release from macrophages is approximately 8.45 μ M^{[1][2]}. We recommend performing a dose-response experiment starting from a concentration range of 1 μ M to 20 μ M to determine the optimal concentration for your specific cell type and experimental conditions.

Q3: How should I dissolve and store **JC-171**?

A3: **JC-171** is typically soluble in dimethyl sulfoxide (DMSO). For cell-based assays, it is crucial to keep the final DMSO concentration in the culture medium low (generally below 0.5%) to avoid solvent-induced cytotoxicity^{[3][4]}. Prepare a high-concentration stock solution of **JC-171** in DMSO (e.g., 10 mM) and then dilute it in your cell culture medium to the desired final concentration immediately before use. Store the DMSO stock solution at -20°C for long-term stability. Avoid repeated freeze-thaw cycles.

Q4: Can **JC-171** affect cell viability?

A4: While **JC-171** is designed to be a specific inhibitor, high concentrations of any small molecule can potentially affect cell viability. It is essential to perform a cytotoxicity assay (e.g., MTT, LDH, or Trypan Blue exclusion) to determine the non-toxic concentration range of **JC-171** for your specific cell type. This should be done in parallel with your primary functional assays.

Troubleshooting Guide

Issue	Possible Cause	Recommended Solution
No or weak inhibition of IL-1 β release	Inadequate concentration of JC-171.	Perform a dose-response experiment with a broader concentration range (e.g., 0.1 μ M to 50 μ M).
Ineffective NLRP3 inflammasome activation.	Ensure your priming (Signal 1, e.g., LPS) and activation (Signal 2, e.g., ATP, Nigericin) steps are working correctly. Include positive controls (activator alone) and negative controls (no activator).	
JC-171 degradation.	Prepare fresh dilutions of JC-171 from a properly stored stock solution for each experiment.	
High background signal in assays	Contamination of reagents or cell culture.	Use sterile techniques and fresh, high-quality reagents.
Non-specific effects of JC-171 or DMSO.	Test a range of DMSO concentrations to ensure the vehicle itself is not causing the high background. Lower the concentration of JC-171 if possible.	
Inconsistent results between experiments	Variability in cell density or health.	Standardize cell seeding density and ensure cells are in a healthy, logarithmic growth phase.
Inconsistent incubation times.	Precisely control the timing of cell priming, inhibitor treatment, and inflammasome activation.	

Pipetting errors.	Use calibrated pipettes and be meticulous with dilutions and additions.
-------------------	-------------------------------------------------------------------------

Unexpected effects on other signaling pathways	Off-target effects of JC-171.	To confirm the specificity of JC-171 for the NLRP3 inflammasome, test its effect on other inflammasomes (e.g., AIM2 or NLRC4) if your experimental system allows.
------------------------------------------------	-------------------------------	-------------------------------------------------------------------------------------------------------------------------------------------------------------------

Experimental Protocols

Protocol 1: Optimizing JC-171 Concentration for Inhibition of IL-1 β Release

This protocol outlines the steps to determine the optimal concentration of **JC-171** for inhibiting NLRP3 inflammasome-mediated IL-1 β release in macrophages.

Materials:

- Macrophage cell line (e.g., J774A.1 or primary bone marrow-derived macrophages)
- Complete cell culture medium
- **JC-171**
- DMSO
- Lipopolysaccharide (LPS)
- ATP or Nigericin
- ELISA kit for IL-1 β
- 96-well cell culture plates

Procedure:

- **Cell Seeding:** Seed macrophages in a 96-well plate at a density of 1×10^5 cells/well and allow them to adhere overnight.
- **JC-171 Preparation:** Prepare a 2X stock solution of **JC-171** in complete culture medium at various concentrations (e.g., 2 μ M, 10 μ M, 20 μ M, 40 μ M). Also, prepare a 2X vehicle control with the same final DMSO concentration.
- **Priming (Signal 1):** Prime the cells with LPS (e.g., 1 μ g/mL) for 3-4 hours.
- **Inhibitor Treatment:** After priming, remove the LPS-containing medium and add 50 μ L of the 2X **JC-171** dilutions or vehicle control to the respective wells. Incubate for 1 hour.
- **Activation (Signal 2):** Add 50 μ L of a 2X solution of the NLRP3 activator (e.g., 5 mM ATP for 30 minutes or 10 μ M Nigericin for 1 hour).
- **Sample Collection:** Centrifuge the plate and collect the supernatant for IL-1 β measurement.
- **ELISA:** Quantify the amount of IL-1 β in the supernatants using a commercial ELISA kit according to the manufacturer's instructions.
- **Data Analysis:** Plot the IL-1 β concentration against the **JC-171** concentration to determine the dose-response curve and the IC50 value.

Quantitative Data Summary:

JC-171 Concentration (μ M)	IL-1 β Release (% of Control)
0 (Vehicle)	100%
1	~90%
5	~60%
8.45 (IC50)	50%
10	~40%
20	~15%

Note: These are representative data and may vary depending on the cell type and experimental conditions.

Protocol 2: Assessing the Effect of JC-171 on Caspase-1 Activation by Western Blot

This protocol describes how to evaluate the inhibitory effect of **JC-171** on the cleavage of pro-caspase-1 to its active p20 subunit.

Materials:

- Cells and reagents for inflammasome activation as in Protocol 1
- 6-well cell culture plates
- Lysis buffer (e.g., RIPA buffer with protease inhibitors)
- Protein concentration assay kit (e.g., BCA)
- SDS-PAGE gels and running buffer
- Transfer buffer and PVDF membrane
- Blocking buffer (e.g., 5% non-fat milk in TBST)
- Primary antibody against caspase-1 (p20 subunit)
- HRP-conjugated secondary antibody
- Chemiluminescent substrate

Procedure:

- Cell Treatment: Follow steps 1-5 from Protocol 1, but perform the experiment in 6-well plates with a higher cell number (e.g., 1×10^6 cells/well).
- Lysate Preparation: After treatment, collect the cell culture supernatant and lyse the cells with lysis buffer. Combine the supernatant and cell lysate to analyze both intracellular and

secreted cleaved caspase-1.

- Protein Quantification: Determine the protein concentration of each sample.
- Western Blotting: a. Load equal amounts of protein onto an SDS-PAGE gel. b. Separate the proteins by electrophoresis. c. Transfer the proteins to a PVDF membrane. d. Block the membrane with blocking buffer for 1 hour. e. Incubate the membrane with the primary antibody against cleaved caspase-1 (p20) overnight at 4°C. f. Wash the membrane and incubate with the HRP-conjugated secondary antibody for 1 hour at room temperature. g. Detect the protein bands using a chemiluminescent substrate and an imaging system.
- Data Analysis: Quantify the band intensity of the cleaved caspase-1 p20 subunit relative to a loading control (e.g., β -actin from the cell lysate fraction).

Expected Results:

JC-171 Concentration (μ M)	Cleaved Caspase-1 (p20) Intensity (Arbitrary Units)
0 (Vehicle)	+++
5	++
10	+
20	-

Note: The intensity is represented qualitatively. Quantitative densitometry should be performed for accurate analysis.

Signaling Pathway and Experimental Workflow Diagrams

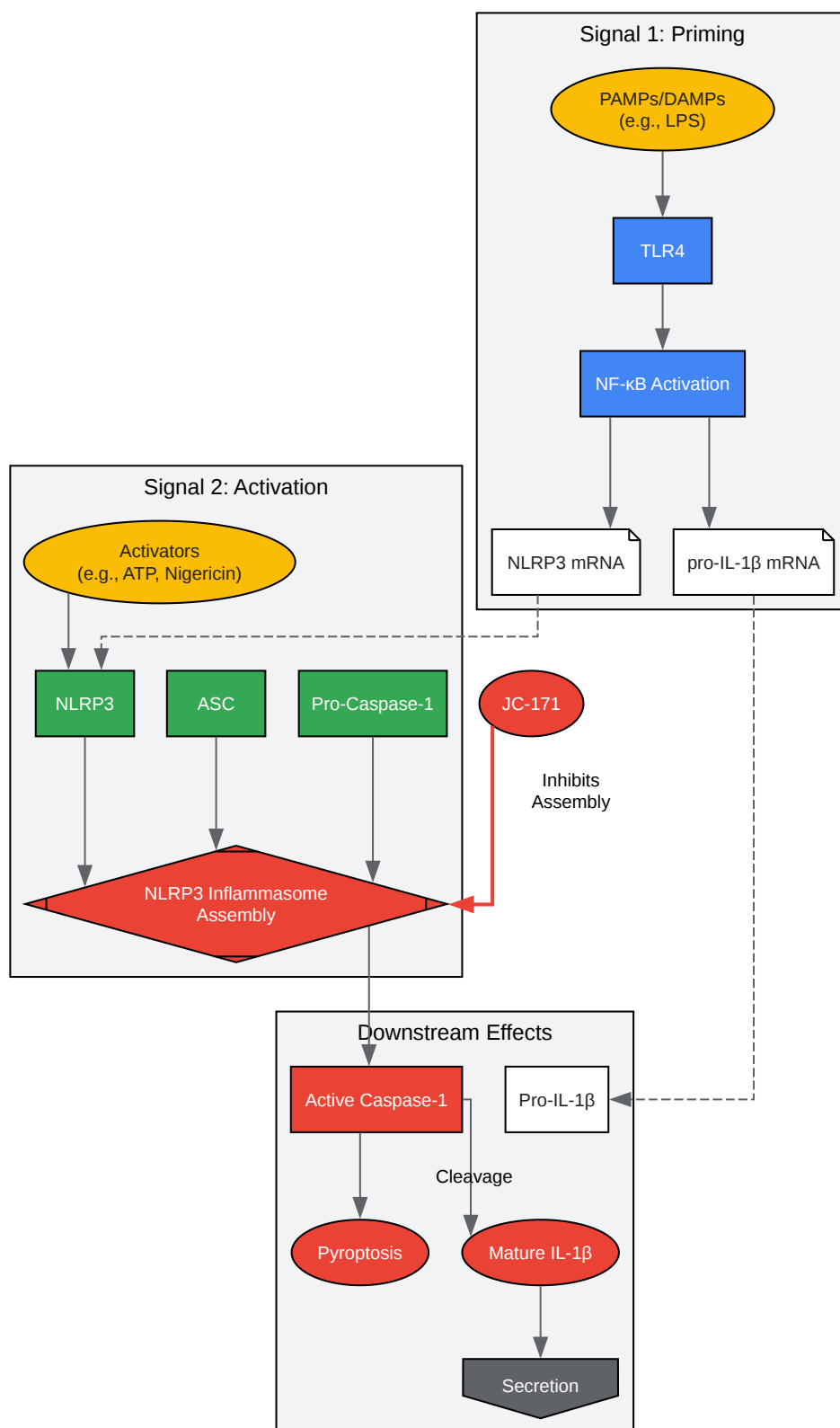

[Click to download full resolution via product page](#)

Caption: NLRP3 Inflammasome Activation Pathway and the inhibitory action of **JC-171**.

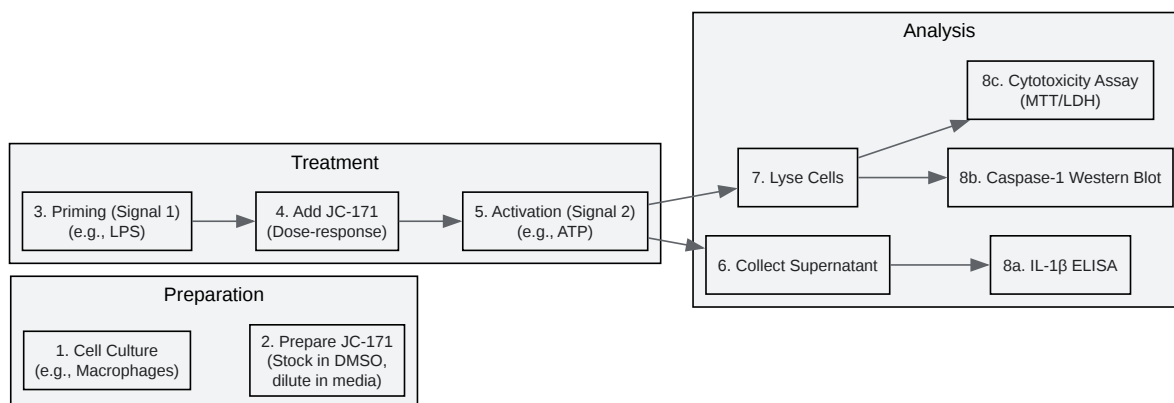

[Click to download full resolution via product page](#)

Caption: General experimental workflow for optimizing **JC-171** concentration in cell-based assays.

Need Custom Synthesis?

BenchChem offers custom synthesis for rare earth carbides and specific isotopic labeling.

Email: info@benchchem.com or [Request Quote Online](#).

References

- [1. Techniques to Study Inflammasome Activation and Inhibition by Small Molecules \[mdpi.com\]](#)
- [2. researchgate.net \[researchgate.net\]](#)
- [3. Dimethyl sulfoxide affects the viability and mineralization activity of apical papilla cells in vitro - PMC \[pmc.ncbi.nlm.nih.gov\]](#)
- [4. Using live-cell imaging in cell counting The cytotoxicity of DMSO | Case studies | Cell x Image Lab - Nikon \[healthcare.nikon.com\]](#)

- To cite this document: BenchChem. [Optimizing JC-171 Concentration for Assays: A Technical Support Guide]. BenchChem, [2026]. [Online PDF]. Available at: [<https://www.benchchem.com/product/b8117439/docs#optimizing-jc-171-concentration-for-assays-a-technical-support-guide>]

Disclaimer & Data Validity:

The information provided in this document is for Research Use Only (RUO) and is strictly not intended for diagnostic or therapeutic procedures. While BenchChem strives to provide accurate protocols, we make no warranties, express or implied, regarding the fitness of this product for every specific experimental setup.

Technical Support: The protocols provided are for reference purposes. Unsure if this reagent suits your experiment?

Need Industrial/Bulk Grade? [Request Custom Synthesis Quote](#)

BenchChem

Our mission is to be the trusted global source of essential and advanced chemicals, empowering scientists and researchers to drive progress in science and industry.

Contact

Address: 3281 E Guasti Rd
Ontario, CA 91761, United States
Phone: (601) 213-4426
Email: info@benchchem.com

[Contact our Ph.D. Support Team for a compatibility check](#)