

Technical Guide: HyNic-PEG2-DBCO Structure, Properties, and Bioconjugation Protocols[1]

Author: BenchChem Technical Support Team. **Date:** April 2026

Compound of Interest

Compound Name: HyNic-PEG2-DBCO

Cat. No.: B8115956

[Get Quote](#)

Executive Summary

HyNic-PEG2-DBCO is a heterobifunctional crosslinker designed for high-specificity bioconjugation. It bridges two distinct chemical modalities: hydrazine-aldehyde chemistry and copper-free click chemistry (SPAAC). This dual-reactivity profile allows researchers to couple biomolecules (e.g., antibodies, enzymes, oligonucleotides) with orthogonal control, minimizing off-target crosslinking.

The linker features a 6-hydrazinonicotinamide (HyNic) moiety, a polyethylene glycol (PEG2) spacer, and a dibenzocyclooctyne (DBCO) group. Its primary utility lies in the synthesis of Antibody-Drug Conjugates (ADCs), PROTACs, and multiplexed diagnostic probes where precise stoichiometry and bond stability are critical.

Part 1: Chemical Architecture & Physicochemical Properties

Structural Composition

The molecule is engineered with three functional zones, each serving a distinct role in the conjugation process:

- HyNic Moiety (6-hydrazinonicotinamide): An aromatic hydrazine that reacts specifically with aldehydes (typically 4-formylbenzamide, 4FB) to form a bis-aryl hydrazone bond. This bond is hyper-stable (stable to 92°C, pH 2–10) and chromophoric.[1]
- PEG2 Spacer: A short, hydrophilic polyethylene glycol linker ()
 . It enhances water solubility and provides rotational flexibility, reducing steric hindrance between the conjugated biomolecules.[2]
- DBCO Moiety (Dibenzocyclooctyne): A strained alkyne ring that undergoes Strain-Promoted Alkyne-Azide Cycloaddition (SPAAC) with azides.[2][3][4][5][6] This reaction is bioorthogonal and requires no copper catalyst, preventing metal-induced protein denaturation.

Physicochemical Properties Table[1][7][8]

Property	Value / Description
Chemical Name	HyNic-PEG2-DBCO
Molecular Weight	~610.7 Da (Free base)
Solubility	Soluble in DMSO, DMF, and aqueous buffers (up to 10 mM with organic co-solvent)
Reactive Groups	Hydrazine (HyNic), Strained Alkyne (DBCO)
Target A	Aldehydes / Ketones (specifically 4FB for stable linkage)
Target B	Azides ()
Bond Stability	Bis-aryl hydrazone: Stable at pH 2–10; Triazole (Click): Irreversible
UV Signature	Bis-aryl hydrazone formation absorbs at 354 nm ()

Part 2: Mechanism of Action

The power of **HyNic-PEG2-DBCO** lies in its orthogonality. The HyNic end reacts only with aldehydes, and the DBCO end reacts only with azides. These reactions do not interfere with each other, allowing for sequential or simultaneous conjugation.

Mechanism 1: Bis-Aryl Hydrazone Formation (HyNic + 4FB)

The HyNic group reacts with an aromatic aldehyde (4-formylbenzamide, 4FB) introduced onto a biomolecule.

- Reaction Type: Nucleophilic addition-elimination (Condensation).
- Key Feature: The resulting bis-aryl hydrazone bond is traceable. The extended conjugation system creates a new absorbance peak at 354 nm, allowing researchers to quantify the exact number of linkers attached without destroying the sample.

Mechanism 2: SPAAC (DBCO + Azide)

The DBCO group reacts with an azide-functionalized payload.^{[2][3][4][5]}

- Reaction Type: [3+2] Cycloaddition.
- Key Feature: The strain energy in the cyclooctyne ring drives the reaction without a catalyst (Copper-free).^{[5][6]} This preserves the biological activity of sensitive proteins that might be damaged by Cu(I).

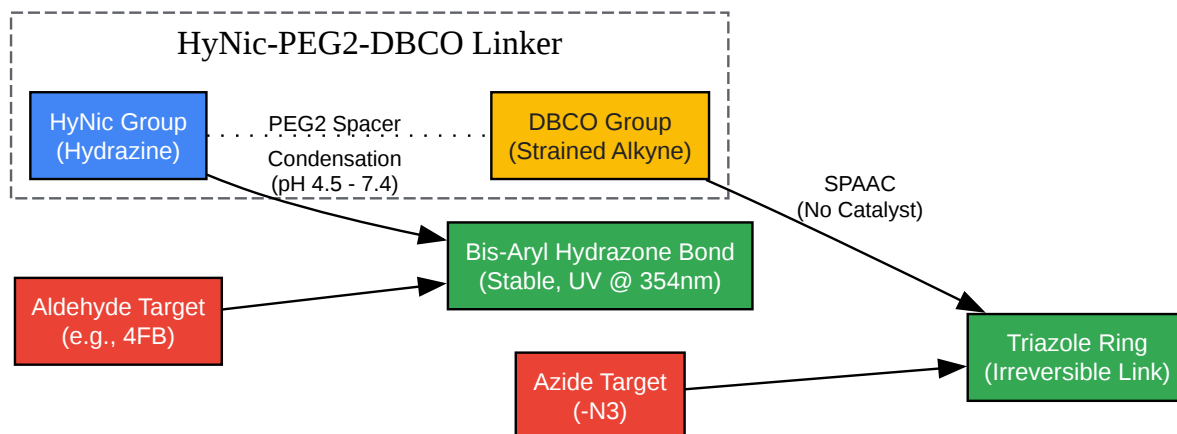

[Click to download full resolution via product page](#)

Figure 1: Dual-mechanistic action of **HyNic-PEG2-DBCO**. The linker facilitates two independent reactions: hydrazine-aldehyde condensation and copper-free click chemistry.

Part 3: Experimental Protocols

Workflow: Protein-Drug Conjugation

This protocol describes linking an Antibody (Target A) to a Small Molecule Drug (Target B).

Prerequisites:

- Antibody Modification: The antibody must be modified with S-4FB (Succinimidyl-4-formylbenzamide) to introduce aldehyde groups.
- Drug Modification: The drug must contain an Azide group.

Step 1: Linker Attachment to Antibody (HyNic-Aldehyde Reaction)

- Buffer Exchange: Exchange the 4FB-modified antibody into Conjugation Buffer (100 mM Sodium Phosphate, 150 mM NaCl, pH 6.0). Note: Acidic pH catalyzes hydrazone formation.
- Linker Preparation: Dissolve **HyNic-PEG2-DBCO** in anhydrous DMSO to 10–50 mM.
- Reaction: Add 5–10 molar equivalents of **HyNic-PEG2-DBCO** to the antibody.

- Why: Excess linker ensures all 4FB sites are occupied by the HyNic end. The DBCO end remains unreacted because there are no azides present.
- Incubation: Incubate for 2 hours at room temperature.
- Purification: Remove excess unreacted linker using a Desalting Column (e.g., Zeba Spin, PD-10) equilibrated in PBS (pH 7.4).
 - Critical Check: Measure Absorbance at 354 nm.^[1] Use the molar extinction coefficient () to calculate the Molar Substitution Ratio (MSR).

Step 2: Payload Conjugation (DBCO-Azide Click Reaction)

- Mixture: Add the Azide-functionalized drug (2–5 equivalents per DBCO group) to the purified Antibody-DBCO intermediate.
- Incubation: Incubate for 4 hours at room temperature or overnight at 4°C. No catalyst is needed.
- Final Purification: Remove excess free drug using Size Exclusion Chromatography (SEC) or dialysis.

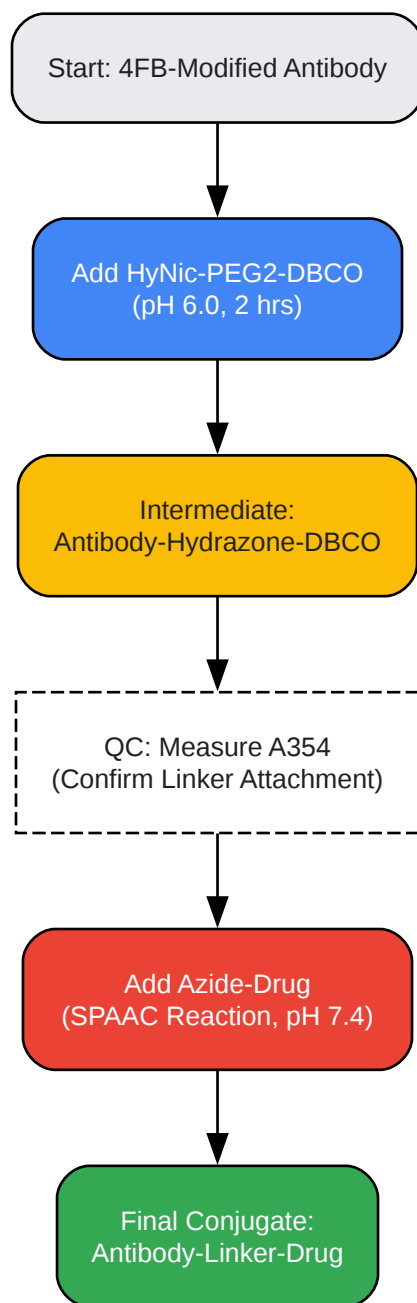

[Click to download full resolution via product page](#)

Figure 2: Step-by-step conjugation workflow for creating an Antibody-Drug Conjugate using HyNic-PEG2-DBCO.

Part 4: Troubleshooting & Expert Insights

Precipitation Issues

- Cause: DBCO is hydrophobic. If the drug payload is also hydrophobic, the final conjugate may aggregate.
- Solution: Ensure the PEG spacer is sufficient. While PEG2 is standard, if aggregation occurs, switch to a linker with a longer PEG chain (e.g., PEG4 or PEG12) to shield the hydrophobic core. Keep organic solvent (DMSO) < 10% during the reaction.

Low Conjugation Yield (HyNic Step)

- Cause: Incorrect pH.
- Solution: The HyNic-4FB reaction is acid-catalyzed. Ensure the reaction buffer is at pH 6.0. Reactions at pH 7.4 are significantly slower and may not reach completion. Aniline (10 mM) can be added as a catalyst to accelerate hydrazone formation if pH 6.0 is not feasible.

Stability Concerns

- Insight: The bis-aryl hydrazone bond is extremely stable compared to aliphatic hydrazones. It does not require reduction (e.g., with NaCNBH₃) to become permanent, unlike Schiff bases formed with simple amines.

References

- MedChemExpress.**HyNic-PEG2-DBCO** Product Data & Structure. Retrieved from
- BroadPharm.DBCO Click Chemistry Reagents and Protocols. Retrieved from
- Vector Laboratories (formerly Solulink).HyNic/4FB Bis-Aryl Hydrazone Chemistry Mechanism. (Contextual grounding for HyNic moiety reactivity).
- BenchChem.Technical Guide to DBCO-PEG-NHS Esters and Click Chemistry. Retrieved from
- Creative PEGWorks.Chemistry of DBCO and SPAAC Reactions. Retrieved from

Need Custom Synthesis?

BenchChem offers custom synthesis for rare earth carbides and specific isotopic labeling.

Email: info@benchchem.com or [Request Quote Online](#).

Sources

- [1. interchim.fr](https://www.interchim.fr) [[interchim.fr](https://www.interchim.fr)]
- [2. pdf.benchchem.com](https://pdf.benchchem.com) [pdf.benchchem.com]
- [3. medchemexpress.com](https://www.medchemexpress.com) [[medchemexpress.com](https://www.medchemexpress.com)]
- [4. medchemexpress.com](https://www.medchemexpress.com) [[medchemexpress.com](https://www.medchemexpress.com)]
- [5. interchim.fr](https://www.interchim.fr) [[interchim.fr](https://www.interchim.fr)]
- [6. chempep.com](https://www.chempep.com) [[chempep.com](https://www.chempep.com)]
- To cite this document: BenchChem. [Technical Guide: HyNic-PEG2-DBCO Structure, Properties, and Bioconjugation Protocols[1]]. BenchChem, [2026]. [Online PDF]. Available at: [<https://www.benchchem.com/product/b8115956/docs#technical-guide-hynic-peg2-dbc-structure-properties-and-bioconjugation-protocols-1>]

Disclaimer & Data Validity:

The information provided in this document is for Research Use Only (RUO) and is strictly not intended for diagnostic or therapeutic procedures. While BenchChem strives to provide accurate protocols, we make no warranties, express or implied, regarding the fitness of this product for every specific experimental setup.

Technical Support: The protocols provided are for reference purposes. Unsure if this reagent suits your experiment?

Need Industrial/Bulk Grade? [Request Custom Synthesis Quote](#)

BenchChem

Our mission is to be the trusted global source of essential and advanced chemicals, empowering scientists and researchers to drive progress in science and industry.

Contact

Address: 3281 E Guasti Rd
Ontario, CA 91761, United States
Phone: (601) 213-4426
Email: info@benchchem.com

Contact our Ph.D. Support Team for a compatibility check