

Cross-validation of TPC2-A1-P Effects with Genetic Approaches: A Comparative Guide

Author: BenchChem Technical Support Team. **Date:** April 2026

Compound of Interest

Compound Name: *Tpc2-A1-P*

Cat. No.: *B8115660*

[Get Quote](#)

For Researchers, Scientists, and Drug Development Professionals

This guide provides an objective comparison of the synthetic small molecule TPC2 agonist, **TPC2-A1-P**, with other molecular probes and genetic methods used to investigate the function of the lysosomal ion channel, Two-Pore Channel 2 (TPC2). Experimental data is presented to support the comparisons, and detailed protocols for key validation experiments are provided.

TPC2-A1-P: A PI(3,5)P₂ Mimetic

TPC2 is a critical regulator of endolysosomal trafficking and calcium (Ca²⁺) signaling.[1][2] Its activity is modulated by endogenous ligands, primarily nicotinic acid adenine dinucleotide phosphate (NAADP) and phosphatidylinositol 3,5-bisphosphate (PI(3,5)P₂).[2][3] These ligands paradoxically confer different ion selectivities to the channel. NAADP activation leads to a Ca²⁺-permeable state, while PI(3,5)P₂ activation results in a predominantly Na⁺-selective channel.[4]

To dissect the distinct roles of these pathways, specific pharmacological tools have been developed. **TPC2-A1-P** is a synthetic, membrane-permeable small molecule that functionally mimics the action of PI(3,5)P₂, inducing a Na⁺-selective current through TPC2. This contrasts with another synthetic agonist, TPC2-A1-N, which acts as a functional mimetic of NAADP, promoting Ca²⁺ permeability.

Comparison of TPC2 Agonists

The functional differences between **TPC2-A1-P**, TPC2-A1-N, and the endogenous ligands are crucial for designing and interpreting experiments aimed at understanding TPC2 physiology.

Table 1: Comparison of TPC2 Agonist Effects

Feature	TPC2-A1-P	TPC2-A1-N	PI(3,5)P ₂ (Endogenous)	NAADP (Endogenous)
Primary Ion Selectivity	Na ⁺ selective	Ca ²⁺ permeable	Na ⁺ selective	Ca ²⁺ permeable
Effect on Cytosolic Ca ²⁺	Minimal direct effect on cytosolic Ca ²⁺ levels.	Induces a modest but detectable increase in cytosolic Ca ²⁺ .	Minimal direct effect on cytosolic Ca ²⁺ .	Induces Ca ²⁺ release from acidic stores.
Effect on Lysosomal pH	Promotes lysosomal exocytosis.	Increases lysosomal pH.	Regulates luminal pH homeostasis.	Can lead to lysosomal alkalinization.
Synergistic Action	Synergizes with TPC2-A1-N to enhance Ca ²⁺ signals.	Synergizes with TPC2-A1-P to enhance Ca ²⁺ signals.	Works synergistically with NAADP.	Works synergistically with PI(3,5)P ₂ .
Membrane Permeability	Membrane permeable.	Membrane permeable.	Anionic, not membrane permeable.	Anionic, not membrane permeable.

Genetic Cross-Validation Approaches

The specificity of pharmacological agents like **TPC2-A1-P** is paramount. Genetic approaches, such as the use of knockout (KO) models and the expression of pore-dead or gain-of-function mutants, are the gold standard for validating on-target effects.

Table 2: Genetic Validation of TPC2-A1-P Effects

Genetic Approach	Expected Outcome with TPC2-A1-P	Rationale
TPC2 Knockout (KO) or Knockdown	Abolished or significantly reduced cellular response to TPC2-A1-P.	Demonstrates that the observed effect is dependent on the presence of the TPC2 protein.
Expression of Pore-Dead TPC2 Mutant (e.g., L265P)	No response to TPC2-A1-P.	Confirms that the agonist's effect requires a functional ion-conducting pore, ruling out non-specific binding effects.
Expression of Gain-of-Function TPC2 Mutant (e.g., M484L)	Potentiated response to TPC2-A1-P.	Shows that the agonist's effect is directly related to TPC2 channel activity.

Signaling Pathways and Experimental Workflows

The differential activation of TPC2 by its ligands initiates distinct downstream signaling cascades. Understanding these pathways is essential for elucidating the multifaceted roles of TPC2 in cellular physiology.

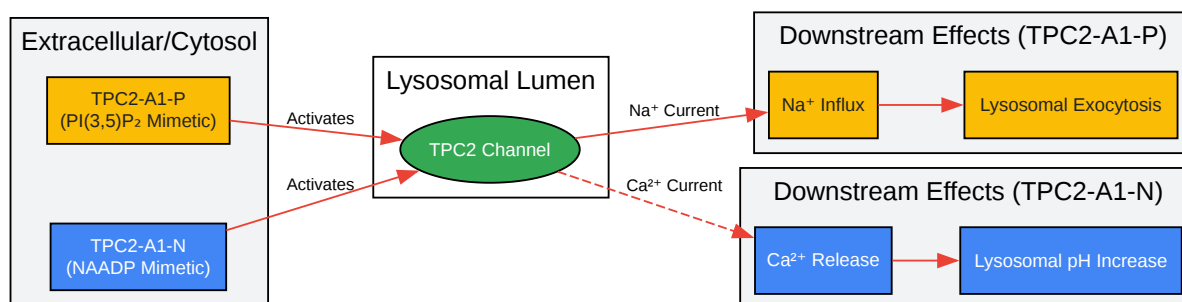

[Click to download full resolution via product page](#)

Figure 1: Differential signaling pathways activated by **TPC2-A1-P** and TPC2-A1-N.

A typical experimental workflow to validate a novel TPC2 agonist involves a combination of pharmacological and genetic approaches to ensure specificity and on-target activity.

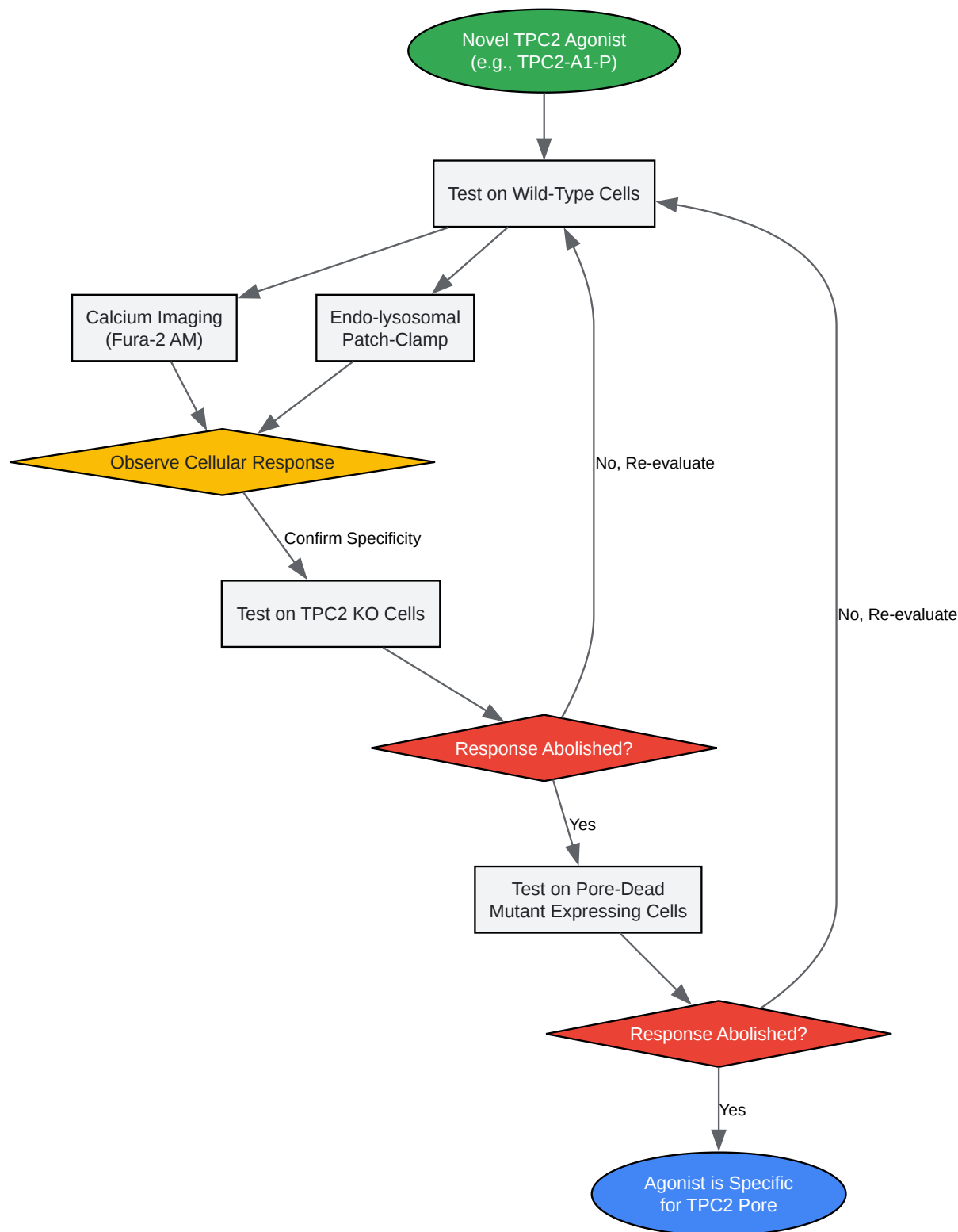

[Click to download full resolution via product page](#)

Figure 2: Experimental workflow for validating the specificity of a TPC2 agonist.

Experimental Protocols

Detailed methodologies are crucial for the reproducibility of experimental findings. Below are protocols for key experiments used in the characterization of **TPC2-A1-P** and its genetic validation.

Endo-lysosomal Patch-Clamp

This technique allows for the direct measurement of ion channel activity in the membranes of endolysosomes.

Materials:

- Cell line of interest (e.g., HEK293 cells transiently expressing human TPC2)
- Vacuolin-1
- Patch-clamp rig with amplifier and data acquisition system
- Borosilicate glass capillaries
- Pipette and bath solutions (ionic compositions will vary depending on the experiment, e.g., symmetric Na⁺ solutions)

Protocol:

- **Enlargement of Endolysosomes:** Treat cells with 1 μ M vacuolin-1 for 1-48 hours to induce the formation of enlarged endolysosomes.
- **Isolation of Enlarged Vesicles:** Manually isolate the enlarged endolysosomes from the cells. A common method involves creating a breach in the cell surface with a micropipette and gently pushing the vesicle out.
- **Patch-Clamp Recording:** Using a patch pipette, form a high-resistance seal (giga-seal) with the membrane of the isolated endolysosome.

- **Whole-Endolysosome Configuration:** Apply a brief pulse of suction to rupture the membrane patch, achieving the whole-endolysosome configuration. This allows for the measurement of the total current across the endolysosomal membrane.
- **Data Acquisition:** Apply voltage protocols and record the resulting currents. Agonists (e.g., **TPC2-A1-P**) and inhibitors can be perfused into the bath solution to observe their effects on channel activity.

Intracellular Calcium Imaging with Fura-2 AM

This method is used to measure changes in cytosolic Ca²⁺ concentration in response to stimuli.

Materials:

- Cells grown on glass coverslips
- Fura-2 AM (acetoxymethyl ester)
- Pluronic F-127
- HEPES-buffered saline (HBS)
- Fluorescence microscopy system equipped for ratiometric imaging (with excitation wavelengths of 340 nm and 380 nm, and an emission filter around 510 nm)

Protocol:

- **Cell Preparation:** Seed cells on glass coverslips and allow them to adhere.
- **Dye Loading:** Prepare a loading solution containing Fura-2 AM (typically 1-5 μM) and Pluronic F-127 (e.g., 0.02%) in HBS. Incubate the cells with the loading solution for 30-60 minutes at room temperature in the dark.
- **De-esterification:** Wash the cells with HBS to remove excess dye and incubate for a further 30 minutes to allow for the complete hydrolysis of the AM ester by intracellular esterases, trapping the active Fura-2 dye inside the cells.

- **Imaging:** Mount the coverslip on the microscope stage. Acquire fluorescence images by alternating excitation at 340 nm and 380 nm. The ratio of the fluorescence intensities (F340/F380) is proportional to the intracellular Ca²⁺ concentration.
- **Data Analysis:** After establishing a baseline, apply TPC2 agonists or other stimuli and record the changes in the F340/F380 ratio over time.

Lysosomal pH Measurement

This protocol uses a pH-sensitive fluorescent dye to measure the pH of the lysosomal lumen.

Materials:

- Cells in culture
- Fluorescein isothiocyanate (FITC)-dextran or LysoSensor™ Yellow/Blue dextran
- Nigericin (for calibration)
- A series of calibration buffers with known pH values
- Flow cytometer or fluorescence microscope capable of ratiometric imaging

Protocol:

- **Dye Loading:** Incubate cells with FITC-dextran (e.g., 0.1 mg/mL) for 48-72 hours. The dextran is taken up by endocytosis and accumulates in lysosomes.
- **Measurement:**
 - **Microscopy:** Acquire fluorescence images at two different emission wavelengths (for dual-emission dyes) or excitation wavelengths (for dual-excitation dyes). The ratio of the intensities is dependent on the pH.
 - **Flow Cytometry:** Analyze the fluorescence of the cells at two different emission wavelengths (e.g., FL1 and FL2 for FITC).

- **Calibration:** To convert the fluorescence ratio to a pH value, a standard curve must be generated. Treat the cells with the H⁺/K⁺ ionophore nigericin in calibration buffers of varying known pH. This equilibrates the lysosomal pH with the extracellular pH.
- **Data Analysis:** Plot the fluorescence ratio against the known pH values of the calibration buffers to generate a standard curve. Use this curve to determine the lysosomal pH of the experimental samples.

Generation of TPC2 Knockout Cells using CRISPR/Cas9

This is a general outline for creating a TPC2 knockout cell line to validate the specificity of **TPC2-A1-P**.

Materials:

- Parental cell line
- CRISPR/Cas9 plasmid vector (e.g., pSpCas9(BB)-2A-Puro)
- Guide RNA (gRNA) targeting an early exon of the TPCN2 gene
- Transfection reagent
- Puromycin (for selection)

Protocol:

- **gRNA Design:** Design a gRNA specific to an early exon of the TPCN2 gene to maximize the likelihood of a frameshift mutation leading to a non-functional protein.
- **Cloning:** Clone the gRNA sequence into the CRISPR/Cas9 vector.
- **Transfection:** Transfect the parental cell line with the gRNA-containing CRISPR/Cas9 plasmid.
- **Selection:** Select for transfected cells using puromycin.
- **Single-Cell Cloning:** Isolate single cells to generate clonal populations.

- **Screening and Validation:** Screen the clonal populations for the absence of TPC2 protein expression (e.g., by Western blot) and for the presence of the desired mutation (by DNA sequencing).

Site-Directed Mutagenesis of TPC2

This protocol allows for the introduction of specific mutations into the TPC2 gene, for example, to create a pore-dead or gain-of-function mutant.

Materials:

- Plasmid containing the wild-type TPC2 cDNA
- Mutagenic primers containing the desired mutation
- High-fidelity DNA polymerase
- DpnI restriction enzyme
- Competent *E. coli* cells

Protocol:

- **Primer Design:** Design a pair of complementary primers that contain the desired mutation and anneal to the TPC2 plasmid.
- **PCR Amplification:** Perform PCR using the TPC2 plasmid as a template and the mutagenic primers. This will amplify the entire plasmid, incorporating the mutation.
- **Template Digestion:** Digest the PCR product with DpnI. DpnI specifically cleaves methylated DNA, so it will digest the parental (template) plasmid, leaving the newly synthesized, unmethylated, mutated plasmid intact.
- **Transformation:** Transform competent *E. coli* cells with the DpnI-treated plasmid.
- **Screening and Verification:** Isolate plasmid DNA from the resulting colonies and verify the presence of the desired mutation by DNA sequencing.

Conclusion

TPC2-A1-P is a valuable pharmacological tool for probing the PI(3,5)P₂-mediated, Na⁺-selective signaling pathway of TPC2. Its utility is significantly enhanced when used in conjunction with its NAADP-mimetic counterpart, TPC2-A1-N, and rigorously validated with genetic approaches. The comparative data and experimental protocols provided in this guide offer a framework for researchers to design and execute robust experiments to further unravel the complex biology of TPC2.

Need Custom Synthesis?

BenchChem offers custom synthesis for rare earth carbides and specific isotopic labeling.

Email: info@benchchem.com or [Request Quote Online](#).

References

- [1. Fura-2 AM calcium imaging protocol | Abcam \[abcam.com\]](#)
- [2. researchgate.net \[researchgate.net\]](#)
- [3. Generation of Nonmosaic, Two-Pore Channel 2 Biallelic Knockout Pigs in One Generation by CRISPR-Cas9 Microinjection Before Oocyte Insemination - PubMed \[pubmed.ncbi.nlm.nih.gov\]](#)
- [4. Simultaneous determination of intraluminal lysosomal calcium and pH by dextran-conjugated fluorescent dyes - PubMed \[pubmed.ncbi.nlm.nih.gov\]](#)
- To cite this document: BenchChem. [Cross-validation of TPC2-A1-P Effects with Genetic Approaches: A Comparative Guide]. BenchChem, [2026]. [Online PDF]. Available at: [\[https://www.benchchem.com/product/b8115660/docs#cross-validation-of-tpc2-a1-p-effects-with-genetic-approaches-a-comparative-guide\]](https://www.benchchem.com/product/b8115660/docs#cross-validation-of-tpc2-a1-p-effects-with-genetic-approaches-a-comparative-guide)

Disclaimer & Data Validity:

The information provided in this document is for Research Use Only (RUO) and is strictly not intended for diagnostic or therapeutic procedures. While BenchChem strives to provide accurate protocols, we make no warranties, express or implied, regarding the fitness of this product for every specific experimental setup.

Technical Support: The protocols provided are for reference purposes. Unsure if this reagent suits your experiment?

Need Industrial/Bulk Grade? [Request Custom Synthesis Quote](#)

BenchChem

Our mission is to be the trusted global source of essential and advanced chemicals, empowering scientists and researchers to drive progress in science and industry.

Contact

Address: 3281 E Guasti Rd

Ontario, CA 91761, United States

Phone: (601) 213-4426

Email: info@benchchem.com

[Contact our Ph.D. Support Team for a compatibility check](#)