

Introduction to Bifunctional PEG Linkers

Author: BenchChem Technical Support Team. **Date:** April 2026

Compound of Interest

Compound Name: *Propargyl-PEG4-S-PEG4-Propargyl*
Cat. No.: *B8106175*

[Get Quote](#)

Polyethylene glycol (PEG) linkers are indispensable tools in modern bioconjugation, serving as flexible, hydrophilic spacers to connect two or more molecular entities.^[1] Their integration into therapeutics, diagnostics, and research reagents is driven by the unique physicochemical properties of the PEG chain, which can enhance the solubility, stability, and pharmacokinetic profiles of the resulting conjugates.^{[2][3]} Bifunctional PEGs, featuring reactive functional groups at both termini of the polymer chain, are particularly crucial for the precise assembly of complex biomolecular architectures, such as antibody-drug conjugates (ADCs).^{[1][3]}

These linkers can be broadly categorized into two main classes:

- **Homobifunctional Linkers:** These possess identical reactive groups at each end, making them suitable for cross-linking identical molecules or for polymerization applications.^{[2][4]}
- **Heterobifunctional Linkers:** These feature two distinct functional groups at their termini.^{[2][5]} This orthogonality allows for the sequential and controlled conjugation of two different molecules, a critical requirement in the development of targeted therapies.^[6] The use of heterobifunctional linkers minimizes the formation of undesirable homodimers and provides precise control over the final conjugate's structure.^[7]

The core advantages of incorporating a PEG spacer in bioconjugation strategies include:

- **Enhanced Hydrophilicity:** PEG linkers improve the aqueous solubility of hydrophobic drugs or proteins, reducing the risk of aggregation.[2][6]
- **Improved Pharmacokinetics:** The hydrodynamic volume of the PEG chain can shield the conjugate from renal clearance, thereby extending its circulation half-life.[8][9]
- **Reduced Immunogenicity:** The flexible and hydrophilic nature of PEG can mask epitopes on proteins, reducing their potential to elicit an immune response.[6]
- **Precise Spatial Control:** The defined length of monodisperse PEG linkers allows for exact control over the distance between the conjugated molecules, which is crucial for optimizing biological activity.[6]

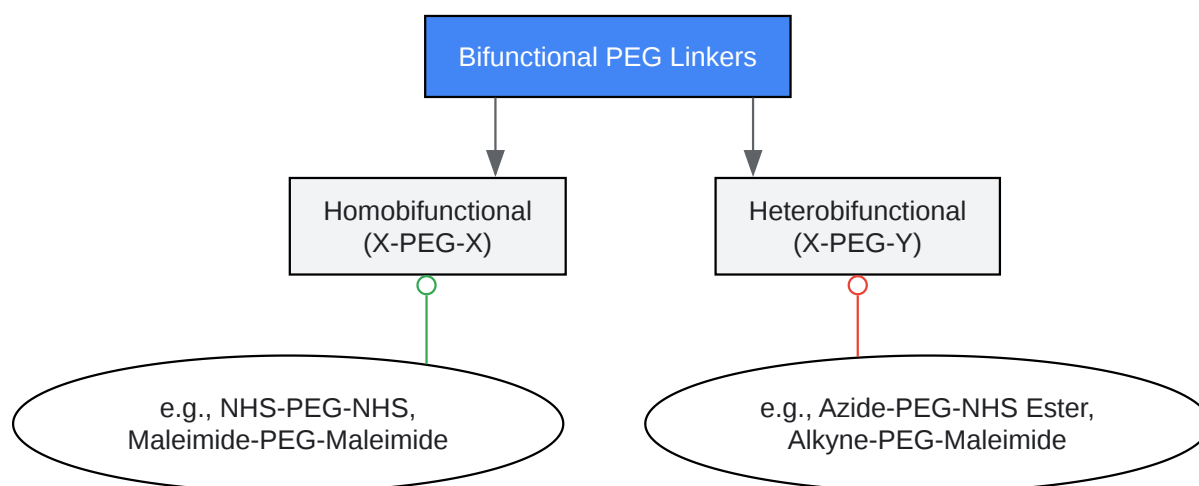

[Click to download full resolution via product page](#)

Figure 1: Classification of bifunctional PEG linkers.

Common Functional Groups and Conjugation Chemistries

The versatility of bifunctional PEG linkers stems from the wide array of reactive functional groups that can be incorporated at their termini. The choice of these groups is dictated by the available reactive sites on the target biomolecules, such as the side chains of amino acids (e.g., lysine, cysteine) or other functional moieties.

Functional Group	Target Moiety	Resulting Bond	Key Characteristics
N-Hydroxysuccinimide (NHS) Ester	Primary Amines (-NH ₂)	Amide	Highly efficient reaction at pH 7.2-8.5. Susceptible to hydrolysis in aqueous buffers.[1]
Maleimide	Thiols / Sulfhydryls (-SH)	Thioether	Highly specific reaction with thiols at pH 6.5-7.5. The resulting bond may have stability issues.[7]
Azide (-N ₃)	Alkynes (-C≡CH)	Triazole	Bio-orthogonal "Click Chemistry" reaction. Can be copper-catalyzed (CuAAC) or strain-promoted (SPAAC).[7]
Alkyne (-C≡CH)	Azides (-N ₃)	Triazole	Partner to the azide group for "Click Chemistry" conjugation.[10]
Hydrazide (-CONHNH ₂)	Carbonyls (Aldehydes, Ketones)	Hydrazone	Forms a stable C=N bond. Useful for site-specific modification of glycoproteins after oxidation.[11]
Carboxylic Acid (-COOH)	Primary Amines (-NH ₂)	Amide	Requires activation with carbodiimides (e.g., EDC) and NHS to form a stable amide bond.[7]

Orthopyridyl Disulfide (OPSS)	Thiols / Sulfhydryls (-SH)	Disulfide	Reacts with thiols to form a disulfide bond, which is cleavable by reducing agents.[12]
-------------------------------	----------------------------	-----------	---

Applications in Drug Development

Bifunctional PEG linkers are central to the design of advanced therapeutics, most notably Antibody-Drug Conjugates (ADCs). In an ADC, a potent cytotoxic drug is linked to a monoclonal antibody that targets a tumor-specific antigen, thereby enabling targeted drug delivery.[5][13]

The linker's role in an ADC is multifaceted:

- **Solubility and Stability:** The PEG component enhances the solubility of the ADC, preventing aggregation, especially with high drug-to-antibody ratios (DAR).[6]
- **Pharmacokinetics:** It helps to prolong the circulation time of the ADC, increasing its chances of reaching the tumor site.[13]
- **Controlled Release:** The linker can be designed to be stable in circulation but cleavable under specific conditions within the target cell (e.g., acidic pH of endosomes or enzymatic cleavage).[2]

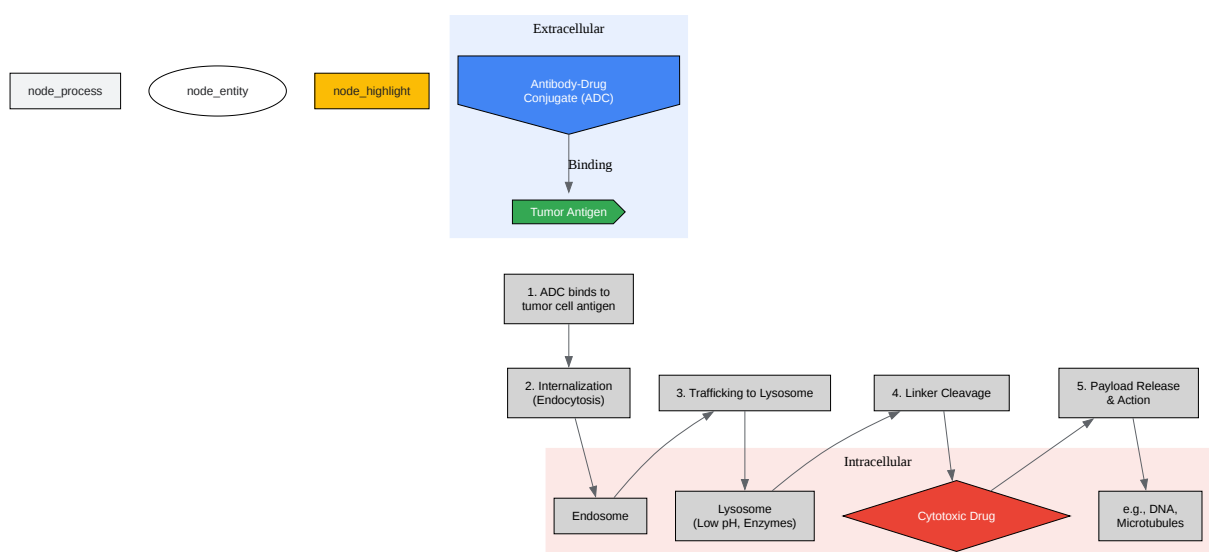

[Click to download full resolution via product page](#)

Figure 2: Generalized mechanism of action for an ADC with a cleavable linker.

Quantitative Impact of PEG Linkers

The length and nature of the PEG linker can have a profound impact on the biological properties of the conjugate. Studies have demonstrated a direct correlation between the molecular weight of the PEG chain and the pharmacokinetic profile of the bioconjugate.

Table 1: Effect of PEG Linker Length on Miniaturized ADC Properties Data synthesized from a study on affibody-based drug conjugates.[8]

Conjugate	PEG Molecular Weight (kDa)	Half-Life Extension (Fold Change vs. No PEG)	In Vitro Cytotoxicity Reduction (Fold Change vs. No PEG)
HM	0 (SMCC Linker)	1.0	1.0
HP4KM	4	2.5	4.5
HP10KM	10	11.2	22.0

These data illustrate a critical trade-off in linker design: while longer PEG chains significantly extend the conjugate's half-life, they can also increase steric hindrance, potentially reducing binding affinity or cytotoxic potency.[8]

Table 2: Impact of PEG Linker Length on Dimeric Ligand Binding Affinity Data from a study on dimeric modulators for the CXCR4 receptor.[14]

Dimeric Ligand	PEG Linker	IC ₅₀ (nM)
(DV3-PEG ₃) ₂ K	PEG ₃	22
(DV3-PEG ₅) ₂ K	PEG ₅	23
(DV3-PEG ₇) ₂ K	PEG ₇	25

In this case, increasing the PEG linker length beyond PEG₃ did not improve the binding affinity, suggesting an optimal spatial distance had been achieved.[14]

Experimental Protocols

Detailed and reproducible protocols are essential for the successful synthesis and application of bifunctional PEG linkers.

Protocol: Synthesis of a Heterobifunctional PEG (α -hydroxyl- ω -azide)

This protocol is a representative example based on common chemical routes for modifying symmetrical PEG diols.^[15]

Materials:

- Polyethylene glycol (diol, e.g., 2 kDa)
- Toluene
- Pyridine
- 4-Toluenesulfonyl chloride (TsCl)
- Sodium azide (NaN_3)
- Dichloromethane (DCM)
- Dimethylformamide (DMF)
- Diethyl ether
- Anhydrous sodium sulfate (Na_2SO_4)

Procedure:

- **Azeotropic Drying:** Dissolve PEG-diol in toluene and perform azeotropic distillation using a Dean-Stark apparatus to remove water. Dry the resulting PEG under vacuum.
- **Monotosylation:** Dissolve the dried PEG in DCM and cool to 0°C . Add pyridine, followed by the dropwise addition of TsCl (0.9-1.0 molar equivalents to PEG) dissolved in DCM. Allow the reaction to stir overnight at room temperature.

- **Work-up and Purification:** Wash the reaction mixture with dilute HCl, followed by saturated sodium bicarbonate and brine. Dry the organic layer over Na_2SO_4 , filter, and precipitate the product (PEG-monotosylate) in cold diethyl ether.
- **Azidation:** Dissolve the purified PEG-monotosylate in DMF. Add sodium azide (NaN_3 , 5-10 molar excess) and heat the reaction at 80-100°C for 12-24 hours.
- **Final Purification:** Cool the reaction mixture and precipitate the product in cold diethyl ether. Redissolve the crude product in DCM and wash with water to remove excess NaN_3 and DMF. Dry the organic layer, concentrate, and re-precipitate in cold ether to yield the final α -hydroxyl- ω -azide PEG linker.
- **Characterization:** Confirm the structure and purity using ^1H NMR and GPC/SEC.

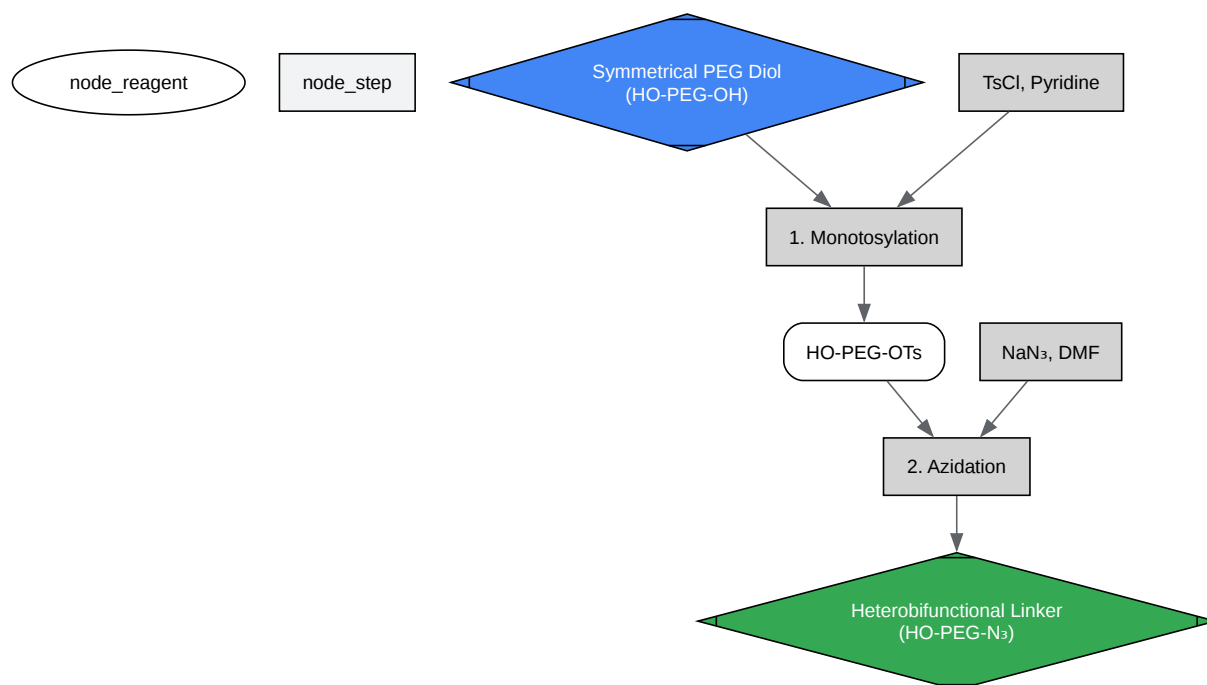

[Click to download full resolution via product page](#)

Figure 3: Workflow for the synthesis of a heterobifunctional PEG linker.

Protocol: Two-Step Conjugation for ADC Synthesis (NHS-PEG-Maleimide)

This protocol outlines a general workflow for conjugating a drug to an antibody using a heterobifunctional linker.^{[1][7][8]}

Materials:

- Monoclonal antibody (mAb) in amine-free buffer (e.g., PBS, pH 7.4)

- NHS-PEG-Maleimide linker
- Thiolated small molecule drug
- Anhydrous DMSO
- Conjugation Buffer (e.g., PBS, pH 7.4)
- Quenching reagent (e.g., Tris or glycine solution)
- Purification system (e.g., Size Exclusion Chromatography - SEC)

Procedure: Step 1: Antibody-Linker Conjugation

- **Antibody Preparation:** Ensure the antibody is at a suitable concentration (e.g., 5-10 mg/mL) in an amine-free buffer.
- **Linker Preparation:** Immediately before use, dissolve the NHS-PEG-Maleimide linker in anhydrous DMSO to a known concentration (e.g., 10 mM).
- **Conjugation Reaction:** Add a calculated molar excess (e.g., 5-10 fold) of the linker solution to the antibody solution. Incubate at room temperature for 1-2 hours with gentle mixing.
- **Purification:** Remove excess, unreacted linker from the antibody-linker conjugate (mAb-PEG-Maleimide) using SEC or a desalting column, exchanging into a buffer suitable for the next step (e.g., PBS, pH 6.5-7.0).

Step 2: Drug Conjugation

- **Drug Preparation:** Dissolve the thiolated small molecule drug in DMSO.
- **Conjugation Reaction:** Add a molar excess (e.g., 3-5 fold) of the drug solution to the purified mAb-PEG-Maleimide conjugate.
- **Incubation:** Allow the reaction to proceed for 2-4 hours at room temperature or overnight at 4°C. If necessary, purge the reaction vessel with nitrogen or argon to prevent thiol oxidation.

- Quenching: Add a quenching reagent like N-ethylmaleimide or cysteine to cap any unreacted maleimide groups on the antibody.
- Final Purification: Purify the final ADC from excess drug and other reaction components using SEC.
- Characterization: Characterize the final ADC to determine the drug-to-antibody ratio (DAR), purity, and level of aggregation using techniques such as HIC-HPLC, RP-HPLC, and SEC.

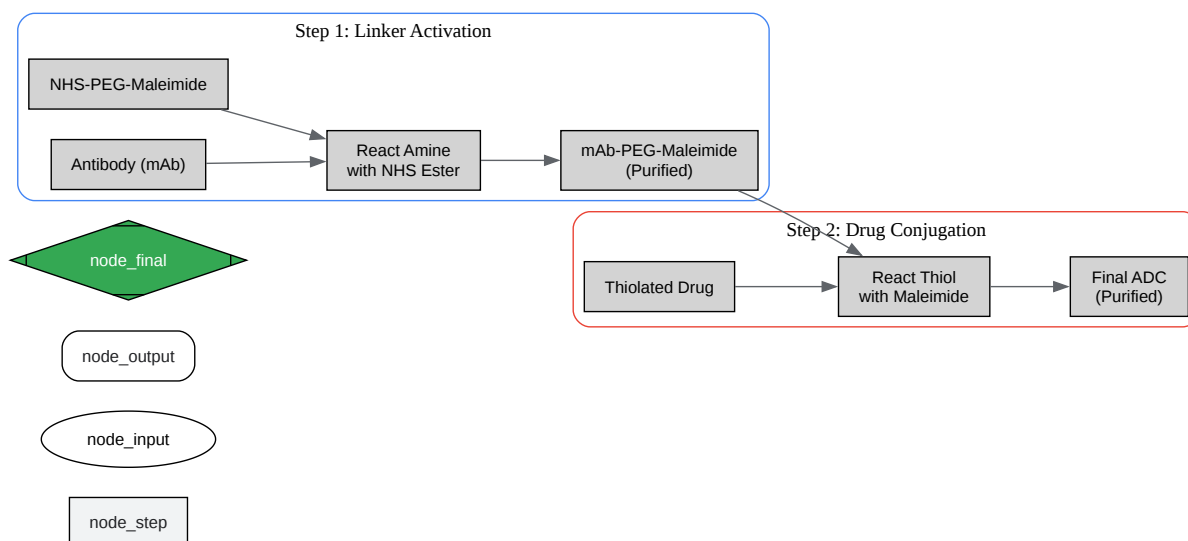

[Click to download full resolution via product page](#)

Figure 4: Experimental workflow for a two-step ADC conjugation.

Need Custom Synthesis?

BenchChem offers custom synthesis for rare earth carbides and specific isotopic labeling.

Email: info@benchchem.com or [Request Quote Online](#).

References

- [1. benchchem.com \[benchchem.com\]](#)
- [2. adc.bocsci.com \[adc.bocsci.com\]](#)
- [3. benchchem.com \[benchchem.com\]](#)
- [4. Homobifunctional Linear PEGs - CD Bioparticles \[cd-bioparticles.net\]](#)
- [5. purepeg.com \[purepeg.com\]](#)
- [6. benchchem.com \[benchchem.com\]](#)
- [7. benchchem.com \[benchchem.com\]](#)
- [8. PEG Linker Improves Antitumor Efficacy and Safety of Affibody-Based Drug Conjugates - PMC \[pmc.ncbi.nlm.nih.gov\]](#)
- [9. What Are PEG Linkers and Their Applications? - Huateng Pharmaceutical CO Ltd \[us.huatengsci.com\]](#)
- [10. researchgate.net \[researchgate.net\]](#)
- [11. interchim.fr \[interchim.fr\]](#)
- [12. Heterobifunctional Linear PEGs - CD Bioparticles \[cd-bioparticles.net\]](#)
- [13. Multi-Arm PEGs for ADCs \[jenkemusa.com\]](#)
- [14. Design, synthesis, and biological characterization of novel PEG-linked dimeric modulators for CXCR4 - PMC \[pmc.ncbi.nlm.nih.gov\]](#)
- [15. mdpi.com \[mdpi.com\]](#)
- To cite this document: BenchChem. [Introduction to Bifunctional PEG Linkers]. BenchChem, [2026]. [Online PDF]. Available at: [<https://www.benchchem.com/product/b8106175/docs#introduction-to-bifunctional-peg-linkers>]

Disclaimer & Data Validity:

The information provided in this document is for Research Use Only (RUO) and is strictly not intended for diagnostic or therapeutic procedures. While BenchChem strives to provide accurate protocols, we make no warranties, express or implied, regarding the fitness of this product for every specific experimental setup.

Technical Support: The protocols provided are for reference purposes. Unsure if this reagent suits your experiment?

Need Industrial/Bulk Grade? [Request Custom Synthesis Quote](#)

BenchChem

Our mission is to be the trusted global source of essential and advanced chemicals, empowering scientists and researchers to drive progress in science and industry.

Contact

Address: 3281 E Guasti Rd
Ontario, CA 91761, United States
Phone: (601) 213-4426
Email: info@benchchem.com

[Contact our Ph.D. Support Team for a compatibility check](#)