

Technical Support Center: Monitoring PEGylation Reaction Progress

Author: BenchChem Technical Support Team. **Date:** April 2026

Compound of Interest

Compound Name: Propargyl-PEG11-methane

Cat. No.: B8104106

[Get Quote](#)

This technical support center provides troubleshooting guides and frequently asked questions (FAQs) to help researchers, scientists, and drug development professionals monitor the progress of their PEGylation reactions effectively.

Frequently Asked Questions (FAQs)

Q1: What is PEGylation and why is it important to monitor?

A1: PEGylation is the process of covalently attaching polyethylene glycol (PEG) chains to molecules such as proteins, peptides, or small molecule drugs.^{[1][2][3]} This modification can improve the therapeutic properties of a biopharmaceutical by increasing its solubility, stability, and circulation half-life, while reducing immunogenicity.^{[3][4][5][6]} Monitoring the reaction is crucial to ensure the desired degree of PEGylation is achieved, as this directly impacts the efficacy and safety of the final product.^[7]

Q2: What are the common methods to monitor the progress of a PEGylation reaction?

A2: Several analytical techniques can be used to monitor the progress of a PEGylation reaction. The choice of method depends on the specific characteristics of the molecule being PEGylated and the PEG reagent used. Common methods include:

- Sodium Dodecyl Sulfate-Polyacrylamide Gel Electrophoresis (SDS-PAGE): A straightforward method to qualitatively visualize the increase in molecular weight of the protein as PEG chains are attached.[8]
- High-Performance Liquid Chromatography (HPLC): A quantitative method that separates the reaction mixture into its components. Size-Exclusion Chromatography (SEC-HPLC) and Reversed-Phase HPLC (RP-HPLC) are frequently used.[6][7]
- Liquid Chromatography-Mass Spectrometry (LC-MS): A highly specific technique that confirms the molecular weight of the PEGylated product, allowing for the determination of the number of attached PEG chains.[8][9][10]
- UV-Vis Spectroscopy: Can be used to quantify PEGylation if the PEG reagent or linker has a chromophore.[8]
- Colorimetric Assays: For example, the barium-iodide assay can quantify the amount of PEG present in a sample.[8]

Troubleshooting Guides

Issue 1: No or Low PEGylation Efficiency

- Possible Cause: Suboptimal reaction conditions (pH, temperature, reaction time).
- Recommended Solution:
 - pH: For amine-specific PEGylation (e.g., using NHS esters), the pH should typically be in the range of 7-9.[11][12] For thiol-specific PEGylation (e.g., using maleimide), a pH range of 6.5-7.5 is recommended.[2]
 - Temperature and Time: These parameters should be optimized for each specific reaction. Start with manufacturer-recommended protocols and adjust as needed. Monitoring the reaction over time can help determine the optimal reaction duration.
- Possible Cause: Inactive PEG reagent.
- Recommended Solution: Ensure the PEG reagent has been stored correctly and has not expired. Use a fresh batch of reagent if there are any doubts about its activity.

- Possible Cause: Low molar ratio of PEG to the target molecule.
- Recommended Solution: Increasing the molar excess of the PEG reagent can drive the reaction towards a higher degree of PEGylation.[13] However, be aware that a large excess can lead to the formation of multi-PEGylated species.

Issue 2: Formation of Multiple PEGylated Products (Heterogeneity)

- Possible Cause: The target molecule has multiple reactive sites (e.g., multiple lysine residues for amine-reactive PEGylation).
- Recommended Solution:
 - To favor mono-PEGylation, use a lower molar excess of the PEG reagent and a shorter reaction time.[13]
 - Site-specific PEGylation strategies can be employed if a homogeneous product is required.[3]
- Possible Cause: Side reactions occurring.
- Recommended Solution: Ensure the reaction pH is within the optimal range to minimize side reactions.[13]

Issue 3: Difficulty in Purifying the Final PEGylated Product

- Possible Cause: Similar physicochemical properties between the desired product and impurities (e.g., unreacted protein, excess PEG, multi-PEGylated species).
- Recommended Solution:
 - Size-Exclusion Chromatography (SEC): Can effectively separate molecules based on size, which is useful for removing unreacted protein and smaller PEG reagents from the larger PEGylated product.[14]
 - Ion-Exchange Chromatography (IEX): Can separate molecules based on charge, which can be effective in separating different PEGylated species.[7]

- Reversed-Phase Chromatography (RPC): Separates based on hydrophobicity and can also be used for purification.[7]

Experimental Protocols

1. Monitoring PEGylation by SDS-PAGE

This protocol provides a basic method to visualize the progress of a PEGylation reaction.

- Materials:
 - Reaction samples at different time points (e.g., 0, 15, 30, 60, 120 minutes)
 - SDS-PAGE loading buffer
 - Pre-cast or self-cast polyacrylamide gels
 - SDS-PAGE running buffer
 - Protein molecular weight standards
 - Coomassie Blue stain or other suitable protein stain
- Procedure:
 - Mix aliquots of the reaction mixture taken at different time points with SDS-PAGE loading buffer.
 - Heat the samples at 95°C for 5 minutes.
 - Load the samples and a molecular weight marker onto the polyacrylamide gel.
 - Run the gel according to the manufacturer's instructions.
 - Stain the gel with Coomassie Blue to visualize the protein bands.
 - De-stain the gel and analyze the results. An increase in the molecular weight of the target protein over time indicates successful PEGylation.[8]

2. Monitoring PEGylation by SEC-HPLC

This protocol outlines a general procedure for monitoring a PEGylation reaction using Size-Exclusion Chromatography.

- Materials:
 - HPLC system with a UV detector
 - SEC column suitable for the size range of your protein and PEGylated product
 - Mobile phase (e.g., phosphate-buffered saline)
 - Reaction samples at different time points
- Procedure:
 - Equilibrate the SEC column with the mobile phase until a stable baseline is achieved.
 - Inject a sample of the reaction mixture onto the column.
 - Run the HPLC method, monitoring the eluent at a suitable wavelength (e.g., 280 nm for proteins).
 - Analyze the resulting chromatogram. The un-PEGylated protein will elute at a specific retention time. As the reaction progresses, new peaks corresponding to mono-, di-, and multi-PEGylated species will appear at earlier retention times due to their increased size. [\[11\]](#)[\[15\]](#)
 - The area under each peak can be used to quantify the relative amounts of each species in the reaction mixture.

Data Presentation

Table 1: Example Data from SEC-HPLC Monitoring of a PEGylation Reaction

Reaction Time (minutes)	Unmodified Protein (%)	Mono-PEGylated Protein (%)	Di-PEGylated Protein (%)
0	100	0	0
30	45	50	5
60	15	70	15
120	5	65	30

Visualizations

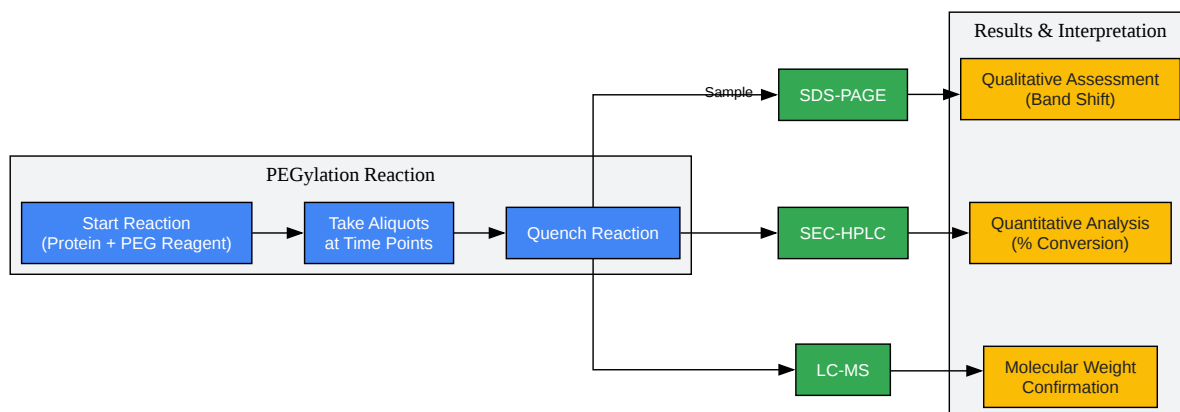

[Click to download full resolution via product page](#)

Caption: Workflow for monitoring a PEGylation reaction.

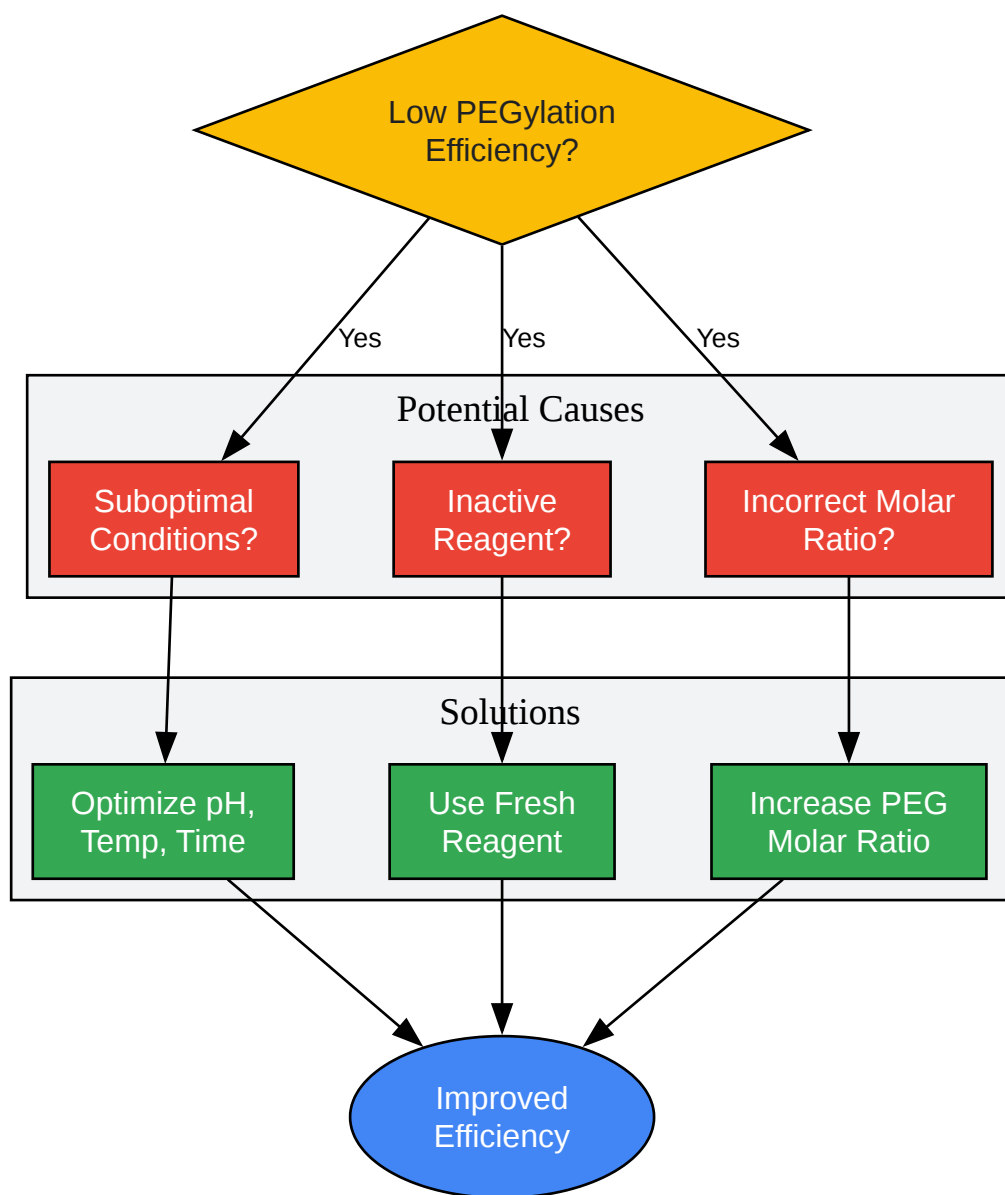

[Click to download full resolution via product page](#)

Caption: Troubleshooting low PEGylation efficiency.

Need Custom Synthesis?

BenchChem offers custom synthesis for rare earth carbides and specific isotopic labeling.

Email: info@benchchem.com or [Request Quote Online](#).

References

- [1. PEG-modified biopharmaceuticals - PubMed \[pubmed.ncbi.nlm.nih.gov\]](#)
- [2. PEGylation and PEGylation Reagents | BroadPharm \[broadpharm.com\]](#)
- [3. europeanpharmaceuticalreview.com \[europeanpharmaceuticalreview.com\]](#)
- [4. chromatographyonline.com \[chromatographyonline.com\]](#)
- [5. biopharmaspec.com \[biopharmaspec.com\]](#)
- [6. Protein PEGylation Analysis - Creative Proteomics \[creative-proteomics.com\]](#)
- [7. lcms.cz \[lcms.cz\]](#)
- [8. creativepegworks.com \[creativepegworks.com\]](#)
- [9. Characterization of PEGylated biopharmaceutical products by LC/MS and LC/MS/MS - PubMed \[pubmed.ncbi.nlm.nih.gov\]](#)
- [10. Characterization of PEGylated Biopharmaceutical Products by LC/MS and LC/MS/MS | Springer Nature Experiments \[experiments.springernature.com\]](#)
- [11. tools.thermofisher.com \[tools.thermofisher.com\]](#)
- [12. idosi.org \[idosi.org\]](#)
- [13. benchchem.com \[benchchem.com\]](#)
- [14. biopharminternational.com \[biopharminternational.com\]](#)
- [15. researchgate.net \[researchgate.net\]](#)
- To cite this document: BenchChem. [Technical Support Center: Monitoring PEGylation Reaction Progress]. BenchChem, [2026]. [Online PDF]. Available at: [\[https://www.benchchem.com/product/b8104106/docs#technical-support-center-monitoring-pegylation-reaction-progress\]](https://www.benchchem.com/product/b8104106/docs#technical-support-center-monitoring-pegylation-reaction-progress)

Disclaimer & Data Validity:

The information provided in this document is for Research Use Only (RUO) and is strictly not intended for diagnostic or therapeutic procedures. While BenchChem strives to provide accurate protocols, we make no warranties, express or implied, regarding the fitness of this product for every specific experimental setup.

Technical Support: The protocols provided are for reference purposes. Unsure if this reagent suits your experiment?

Need Industrial/Bulk Grade? [Request Custom Synthesis Quote](#)

BenchChem

Our mission is to be the trusted global source of essential and advanced chemicals, empowering scientists and researchers to drive progress in science and industry.

Contact

Address: 3281 E Guasti Rd
Ontario, CA 91761, United States
Phone: (601) 213-4426
Email: info@benchchem.com

[Contact our Ph.D. Support Team for a compatibility check](#)