

Application Notes and Protocols for the Reaction of Propargyl Groups with Azides

Author: BenchChem Technical Support Team. **Date:** April 2026

Compound of Interest

Compound Name: Propargyl-PEG11-methane

Cat. No.: B8104106

[Get Quote](#)

For Researchers, Scientists, and Drug Development Professionals

These application notes provide a comprehensive guide to the two primary methods for reacting propargyl groups with azides: the Copper(I)-Catalyzed Azide-Alkyne Cycloaddition (CuAAC) and the Strain-Promoted Azide-Alkyne Cycloaddition (SPAAC). This document outlines the underlying principles, offers detailed experimental protocols, presents quantitative data for reaction optimization, and provides troubleshooting guidance for these powerful bioorthogonal ligation techniques.

Copper(I)-Catalyzed Azide-Alkyne Cycloaddition (CuAAC)

The CuAAC reaction is a highly efficient and versatile method for forming a stable 1,2,3-triazole linkage between a terminal alkyne (containing a propargyl group) and an azide.^{[1][2][3][4]} This reaction is widely used in bioconjugation, drug discovery, and materials science due to its reliability, high yields, and stereospecificity.^{[2][3]}

Mechanism of Action

The CuAAC reaction proceeds via a copper(I)-catalyzed mechanism that dramatically accelerates the rate of the cycloaddition compared to the uncatalyzed thermal reaction.[1] The key steps involve the formation of a copper acetylide intermediate, which then reacts with the azide to form the triazole product.[1] The use of a copper(I) catalyst ensures the specific formation of the 1,4-disubstituted triazole regioisomer.

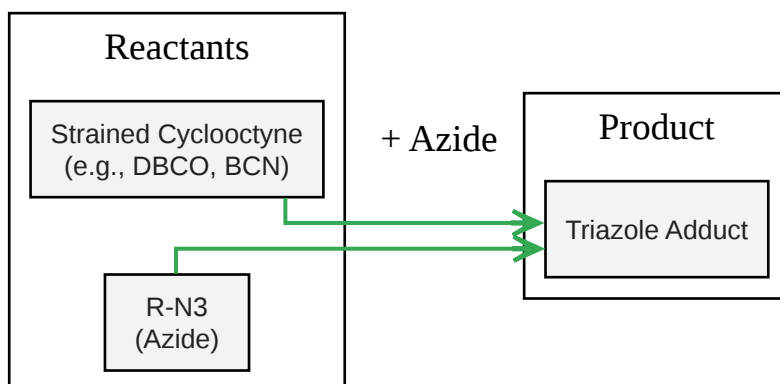
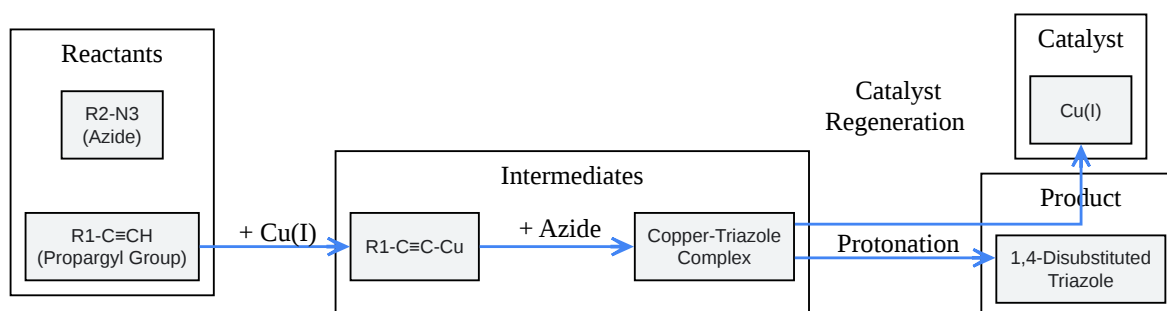

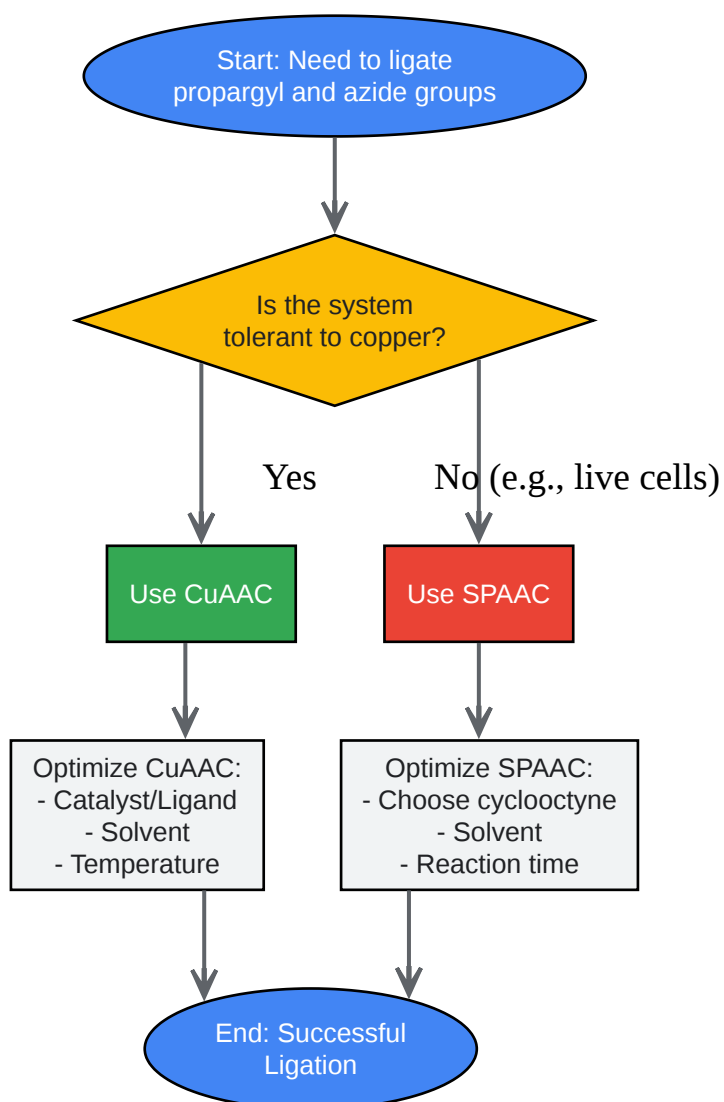

[Click to download full resolution via product page](#)

Need Custom Synthesis?

BenchChem offers custom synthesis for rare earth carbides and specific isotopic labeling.

Email: info@benchchem.com or [Request Quote Online](#).

References

- 1. benchchem.com [benchchem.com]
- 2. Conjugation Based on Click Chemistry - Creative Biolabs [creative-biolabs.com]

- [3. axispharm.com \[axispharm.com\]](https://www.axispharm.com)
- [4. researchgate.net \[researchgate.net\]](https://www.researchgate.net)
- To cite this document: BenchChem. [Application Notes and Protocols for the Reaction of Propargyl Groups with Azides]. BenchChem, [2026]. [Online PDF]. Available at: [\[https://www.benchchem.com/product/b8104106/docs#application-notes-and-protocols-for-the-reaction-of-propargyl-groups-with-azides\]](https://www.benchchem.com/product/b8104106/docs#application-notes-and-protocols-for-the-reaction-of-propargyl-groups-with-azides)

Disclaimer & Data Validity:

The information provided in this document is for Research Use Only (RUO) and is strictly not intended for diagnostic or therapeutic procedures. While BenchChem strives to provide accurate protocols, we make no warranties, express or implied, regarding the fitness of this product for every specific experimental setup.

Technical Support: The protocols provided are for reference purposes. Unsure if this reagent suits your experiment?

Need Industrial/Bulk Grade? [Request Custom Synthesis Quote](#)

BenchChem

Our mission is to be the trusted global source of essential and advanced chemicals, empowering scientists and researchers to drive progress in science and industry.

Contact

Address: 3281 E Guasti Rd
Ontario, CA 91761, United States
Phone: (601) 213-4426
Email: info@benchchem.com

[Contact our Ph.D. Support Team for a compatibility check](#)