

# Application Notes and Protocols for AZD2423 In Vitro Assays

**Author:** BenchChem Technical Support Team. **Date:** April 2026

## Compound of Interest

Compound Name: AZD2423  
CAS No.: 1449698-98-9  
Cat. No.: B8103996

[Get Quote](#)

For Researchers, Scientists, and Drug Development Professionals

## Introduction

**AZD2423** is a potent and selective non-competitive, negative allosteric modulator of the C-C chemokine receptor 2 (CCR2).[1] CCR2 and its primary ligand, monocyte chemoattractant protein-1 (MCP-1/CCL2), play a crucial role in the recruitment of monocytes and macrophages to sites of inflammation. This pathway is implicated in a variety of inflammatory and neuropathic pain conditions. These application notes provide detailed protocols for key in vitro assays to characterize the activity of **AZD2423**.

## Data Presentation

### Summary of AZD2423 In Vitro Activity

Assay Type	Cell Line/System	Ligand/Stimulus	Endpoint	IC50 Value
Calcium Flux	CCR2-expressing cells	MCP-1	Inhibition of Ca <sup>2+</sup> mobilization	1.2 nM <sup>[1]</sup>
Chemotaxis	THP-1 cells	MCP-1	Inhibition of cell migration	4 nM <sup>[1]</sup>
Calcium Mobilization	THP-1 cells	MCP-1	Inhibition of Ca <sup>2+</sup> mobilization	4 nM <sup>[1]</sup>
Receptor Binding	-	-	High-affinity binding	2.6 nM

## Signaling Pathway

The following diagram illustrates the canonical CCR2 signaling pathway and the proposed mechanism of action for **AZD2423** as a negative allosteric modulator.

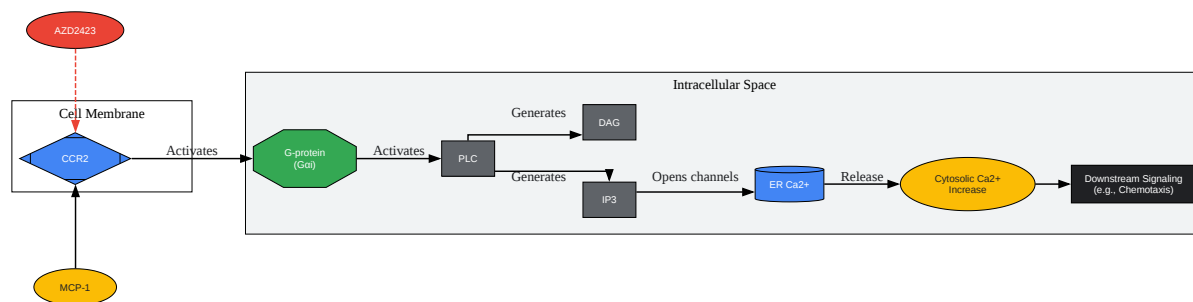

[Click to download full resolution via product page](#)

**Caption:** CCR2 signaling and **AZD2423** mechanism.

## Experimental Protocols

### Calcium Flux Assay

This protocol is designed to measure the inhibitory effect of **AZD2423** on MCP-1-induced intracellular calcium mobilization in a CCR2-expressing cell line, such as THP-1.

Experimental Workflow:

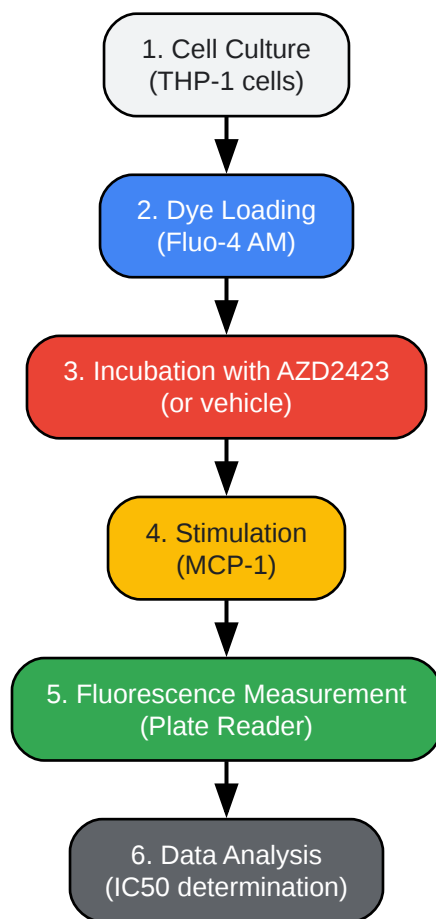

[Click to download full resolution via product page](#)

**Caption:** Calcium flux assay workflow.

Materials:

- THP-1 cells (ATCC TIB-202)
- RPMI-1640 medium with 10% FBS, 2 mM L-glutamine, 10 mM HEPES, 1 mM sodium pyruvate, and 0.05 mM 2-mercaptoethanol
- Recombinant Human MCP-1/CCL2 (carrier-free)
- **AZD2423**
- Fluo-4 AM calcium indicator dye
- Pluronic F-127

- Hanks' Balanced Salt Solution (HBSS) with 20 mM HEPES
- 96-well black, clear-bottom microplates

Protocol:

- Cell Preparation:
  - Culture THP-1 cells in complete RPMI-1640 medium.
  - On the day of the assay, harvest cells and wash with HBSS.
  - Resuspend cells in HBSS at a density of  $1 \times 10^6$  cells/mL.
  - Plate 100  $\mu$ L of the cell suspension per well in a 96-well plate.
- Dye Loading:
  - Prepare a 2X Fluo-4 AM loading solution in HBSS containing 2  $\mu$ M Fluo-4 AM and 0.04% Pluronic F-127.
  - Add 100  $\mu$ L of the 2X loading solution to each well containing cells.
  - Incubate the plate for 60 minutes at 37°C in the dark.
- Compound Incubation:
  - Prepare serial dilutions of **AZD2423** in HBSS.
  - After the dye-loading incubation, gently wash the cells twice with HBSS.
  - Add 100  $\mu$ L of the **AZD2423** dilutions (or vehicle control) to the respective wells.
  - Incubate for 15-30 minutes at room temperature.
- Stimulation and Measurement:
  - Prepare a 5X stock of MCP-1 in HBSS (e.g., 50 nM for a final concentration of 10 nM).

- Place the microplate in a fluorescence plate reader (e.g., FLIPR, FlexStation) equipped with an automated liquid handling system.
- Set the reader to measure fluorescence at Ex/Em = 490/525 nm.
- Establish a baseline fluorescence reading for 10-20 seconds.
- Add 25  $\mu$ L of the 5X MCP-1 solution to each well to initiate the calcium response.
- Continue to record the fluorescence intensity for at least 2-3 minutes.
- Data Analysis:
  - Calculate the change in fluorescence ( $\Delta F$ ) by subtracting the baseline fluorescence from the peak fluorescence for each well.
  - Normalize the data to the vehicle control (0% inhibition) and a maximal inhibition control (100% inhibition).
  - Plot the normalized response against the log concentration of **AZD2423** and fit the data to a four-parameter logistic equation to determine the IC50 value.

## Chemotaxis Assay (Transwell Migration)

This assay measures the ability of **AZD2423** to inhibit the migration of THP-1 cells towards a gradient of MCP-1.

Experimental Workflow:

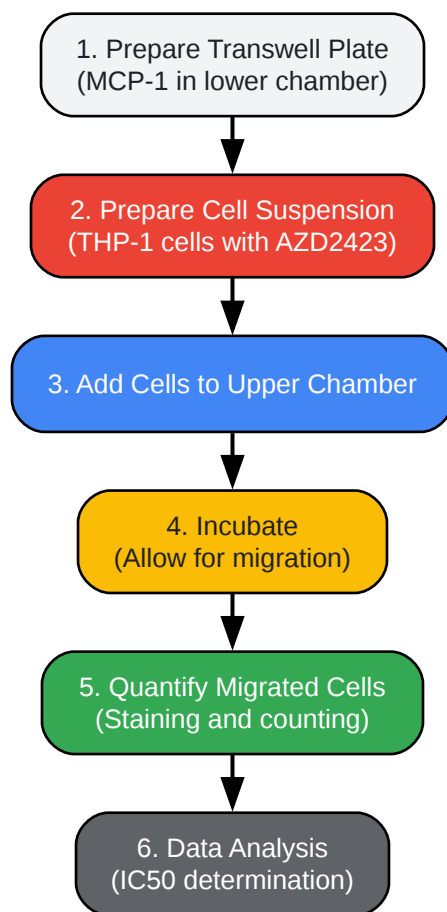

[Click to download full resolution via product page](#)

**Caption:** Chemotaxis assay workflow.

Materials:

- THP-1 cells
- Complete RPMI-1640 medium
- Recombinant Human MCP-1/CCL2
- **AZD2423**
- Transwell inserts (e.g., 24-well format with 5 µm pore size polycarbonate membrane)
- Calcein AM or other suitable fluorescent dye for cell labeling

- Assay buffer (e.g., HBSS with 0.1% BSA)

Protocol:

- Preparation of Transwell Plate:
  - Add assay buffer containing MCP-1 (e.g., 10-50 ng/mL) to the lower chambers of the 24-well plate.
  - Add assay buffer without MCP-1 to the negative control wells.
- Cell Preparation and Compound Treatment:
  - Harvest THP-1 cells and resuspend in assay buffer at a concentration of  $1-2 \times 10^6$  cells/mL.
  - Label the cells with Calcein AM according to the manufacturer's instructions.
  - Prepare serial dilutions of **AZD2423** in the cell suspension.
  - Incubate the cells with **AZD2423** (or vehicle) for 15-30 minutes at room temperature.
- Cell Seeding:
  - Place the Transwell inserts into the wells of the 24-well plate.
  - Add 100  $\mu$ L of the treated THP-1 cell suspension to the upper chamber of each insert.
- Incubation:
  - Incubate the plate at 37°C in a 5% CO<sub>2</sub> incubator for 2-4 hours to allow for cell migration.
- Quantification of Migrated Cells:
  - Carefully remove the Transwell inserts from the plate.
  - Wipe the top surface of the membrane with a cotton swab to remove non-migrated cells.

- Measure the fluorescence of the migrated cells in the lower chamber using a fluorescence plate reader.
- Alternatively, fix and stain the migrated cells on the bottom of the membrane and count them under a microscope.
- Data Analysis:
  - Subtract the background fluorescence (wells with no chemoattractant) from all readings.
  - Normalize the data to the vehicle control (0% inhibition) and a no-migration control (100% inhibition).
  - Plot the normalized migration against the log concentration of **AZD2423** and fit the data to a four-parameter logistic equation to determine the IC50 value.

#### *Need Custom Synthesis?*

*BenchChem offers custom synthesis for rare earth carbides and specific isotopic labeling.*

*Email: [info@benchchem.com](mailto:info@benchchem.com) or [Request Quote Online](#).*

## References

- [1. medchemexpress.com \[medchemexpress.com\]](https://www.medchemexpress.com)
- To cite this document: BenchChem. [Application Notes and Protocols for AZD2423 In Vitro Assays]. BenchChem, [2026]. [Online PDF]. Available at: [\[https://www.benchchem.com/product/b8103996/docs#application-notes-and-protocols-for-azd2423-in-vitro-assays\]](https://www.benchchem.com/product/b8103996/docs#application-notes-and-protocols-for-azd2423-in-vitro-assays)

### Disclaimer & Data Validity:

The information provided in this document is for Research Use Only (RUO) and is strictly not intended for diagnostic or therapeutic procedures. While BenchChem strives to provide accurate protocols, we make no warranties, express or implied, regarding the fitness of this product for every specific experimental setup.

**Technical Support:** The protocols provided are for reference purposes. Unsure if this reagent suits your experiment?

**Need Industrial/Bulk Grade?** [Request Custom Synthesis Quote](#)

## BenchChem

Our mission is to be the trusted global source of essential and advanced chemicals, empowering scientists and researchers to drive progress in science and industry.

### Contact

Address: 3281 E Guasti Rd  
Ontario, CA 91761, United States  
Phone: (601) 213-4426  
Email: [info@benchchem.com](mailto:info@benchchem.com)

[Contact our Ph.D. Support Team for a compatibility check](#)