

# A Comparative Guide to the Catalytic Activity of Cerium Oxide Nanostructures

**Author:** BenchChem Technical Support Team. **Date:** April 2026

## Compound of Interest

Compound Name: Cerous carbonate hydrate

Cat. No.: B8101794

Get Quote

In the dynamic field of heterogeneous catalysis, cerium oxide ( $\text{CeO}_2$ , or ceria) has emerged as a cornerstone material due to its remarkable redox properties and oxygen storage capacity.[1] The catalytic prowess of ceria is intimately linked to its ability to cycle between  $\text{Ce}^{3+}$  and  $\text{Ce}^{4+}$  oxidation states, a process facilitated by the formation of oxygen vacancies in its crystal lattice. [1][2][3] As research delves into the nanoscale, it has become evident that the morphology of ceria nanostructures—specifically nanocubes, nanorods, and nanoparticles—profoundly influences their catalytic performance.[4][5] This guide provides an in-depth comparison of these nanostructures, offering insights into their synthesis, mechanistic differences, and catalytic efficacy, supported by experimental data.

## The Decisive Role of Nanostructure in Catalytic Function

The shape of a ceria nanocrystal is not merely a geometric attribute; it dictates the exposed crystal facets, which in turn determines the concentration and accessibility of active sites, particularly oxygen vacancies.[4][6] These vacancies are crucial for the catalytic cycle in many oxidation reactions.[2][7] Different morphologies preferentially expose different crystal planes, leading to significant variations in catalytic activity.[8]

- Nanorods are characterized by a higher proportion of {110} and {100} facets.[\[6\]](#)[\[8\]](#)
- Nanocubes primarily expose the {100} facets.[\[5\]](#)[\[6\]](#)[\[8\]](#)
- Nano-octahedra and spherical nanoparticles tend to expose the most stable {111} facet.[\[2\]](#)[\[6\]](#)  
[\[8\]](#)

The arrangement of atoms on these facets influences the energy required to form an oxygen vacancy, with the {110} and {100} planes generally exhibiting a higher reactivity compared to the more stable {111} plane.[\[4\]](#)[\[5\]](#)

## Visualizing the Catalytic Cascade

The catalytic cycle for CO oxidation over a ceria nanostructure, a benchmark reaction, typically follows the Mars-van Krevelen mechanism.[\[5\]](#)[\[9\]](#) This process involves the oxidation of CO by lattice oxygen from the ceria surface, creating an oxygen vacancy. This vacancy is then replenished by gas-phase oxygen, completing the cycle. The efficiency of this process is highly dependent on the nanostructure's ability to readily form and fill these oxygen vacancies.

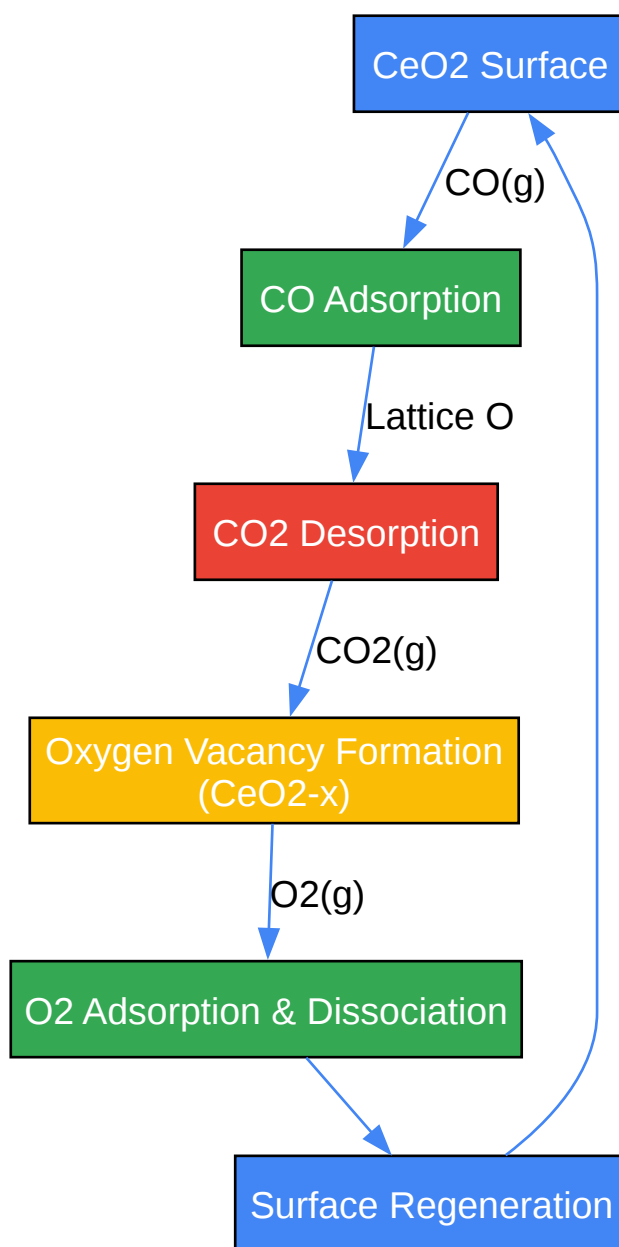

Figure 1: Mars-van Krevelen mechanism for CO oxidation on Ceria.

[Click to download full resolution via product page](#)

Caption: Mars-van Krevelen mechanism for CO oxidation on Ceria.

## Comparative Analysis of Catalytic Performance

Experimental evidence consistently demonstrates a strong correlation between the morphology of ceria nanostructures and their catalytic activity. A notable study compared the performance of palladium supported on ceria nanorods, nanocubes, and nano-octahedra for the selective

oxidation of benzyl alcohol. The results clearly indicated the superior performance of the nanorod-supported catalyst.[6]

Nanostructure	Predominant Facets	Benzyl Alcohol Conversion (%) <sup>[6]</sup>	Key Performance Factors
Nanorods	{110}, {100}	74	High oxygen vacancy concentration, optimal metal-support interaction. <sup>[6]</sup>
Nano-octahedra	{111}	35	Lower oxygen vacancy concentration compared to nanorods. <sup>[6]</sup>
Nanocubes	{100}	28	Weaker metal-support interaction in this specific reaction. <sup>[6]</sup>

Table 1: Comparison of catalytic activity for Pd/CeO<sub>2</sub> nanostructures in benzyl alcohol oxidation.<sup>[6]</sup>

Similarly, in the context of CO oxidation, ceria nanorods and nanocubes generally exhibit higher activity than spherical nanoparticles due to the exposure of more reactive crystal planes.<sup>[5]</sup> The higher concentration of coordinatively unsaturated cerium ions on the {100} and {110} surfaces facilitates the formation of oxygen vacancies, which are the active sites for CO oxidation.<sup>[5]</sup>

## Mechanistic Insights: The "Why" Behind the Activity

The enhanced catalytic activity of nanorods and nanocubes can be attributed to several key factors:

- Oxygen Vacancy Formation Energy:** The energy required to create an oxygen vacancy is lower on the more open {110} and {100} facets compared to the densely packed {111} facet.<sup>[4]</sup> This leads to a higher concentration of active sites on nanorods and nanocubes.

- Redox Properties: The presence of a higher concentration of  $\text{Ce}^{3+}$  ions, associated with oxygen vacancies, enhances the redox properties of the catalyst, facilitating the catalytic cycle.[10][11]
- Metal-Support Interactions: When used as a support for noble metals like palladium or platinum, the morphology of the ceria influences the metal-support interaction.[12][13] Stronger interactions can promote the dispersion of the metal nanoparticles and enhance the overall catalytic activity.[8]

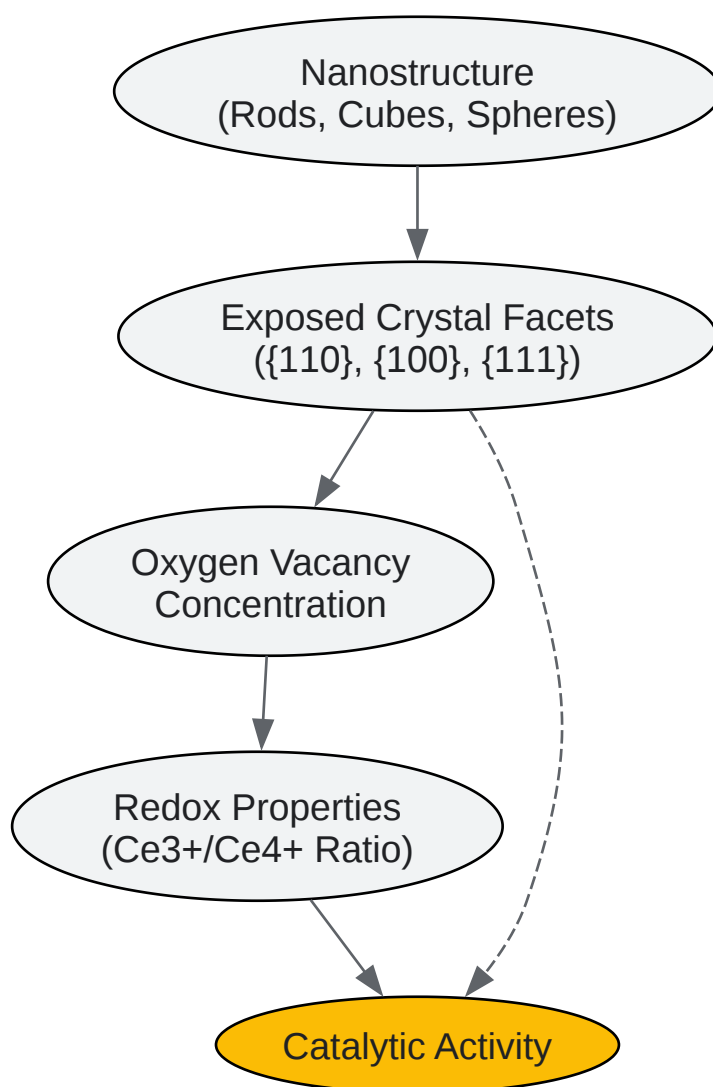

Figure 2: Relationship between  $\text{CeO}_2$  nanostructure and catalytic activity.

[Click to download full resolution via product page](#)

Caption: Relationship between  $\text{CeO}_2$  nanostructure and catalytic activity.

## Experimental Protocols

To ensure the reproducibility and validity of comparative studies, standardized and well-documented experimental protocols are essential.

### Protocol 1: Synthesis of Cerium Oxide Nanostructures

This section outlines representative hydrothermal methods for synthesizing ceria nanocubes and nanorods. These methods are chosen for their ability to yield well-defined morphologies.[\[6\]](#)  
[\[8\]](#)[\[14\]](#)

#### A. Synthesis of Ceria Nanocubes[\[14\]](#)[\[15\]](#)

- Dissolve a specified amount of cerium(III) nitrate hexahydrate in deionized water.
- Add a sodium hydroxide solution dropwise under vigorous stirring to achieve a specific pH, typically in the basic range.
- Transfer the resulting suspension to a Teflon-lined stainless-steel autoclave.
- Heat the autoclave in an oven at a controlled temperature (e.g., 180°C) for a defined period (e.g., 24 hours).[\[16\]](#)
- After cooling to room temperature, collect the precipitate by centrifugation.
- Wash the product repeatedly with deionized water and ethanol to remove any unreacted precursors and byproducts.
- Dry the final product in an oven at a moderate temperature (e.g., 60-80°C).

#### B. Synthesis of Ceria Nanorods[\[6\]](#)[\[17\]](#)

- Prepare an aqueous solution of cerium(III) nitrate hexahydrate.
- Separately, prepare a concentrated solution of sodium hydroxide.
- Under vigorous stirring, rapidly add the sodium hydroxide solution to the cerium nitrate solution.

- Transfer the resulting mixture to a Teflon-lined autoclave.
- Maintain the autoclave at a specific temperature (e.g., 100-120°C) for a designated time (e.g., 24 hours).
- Follow the same collection, washing, and drying procedures as for the nanocubes.

### C. Synthesis of Ceria Nanoparticles (Co-precipitation)[18][19]

- Prepare an aqueous solution of cerium(III) nitrate hexahydrate.
- Prepare a precipitating agent solution, such as ammonium hydroxide or potassium carbonate.[18]
- Add the precipitating agent dropwise to the cerium nitrate solution under constant stirring, maintaining a constant pH.[18]
- Age the resulting precipitate at a specific temperature.
- Collect, wash, and dry the nanoparticles as described above.
- Calcination at a higher temperature (e.g., 600°C) is often performed to improve crystallinity. [18]

## Protocol 2: Evaluation of Catalytic Activity

A standardized method for assessing the catalytic performance is crucial for objective comparison. CO oxidation is a commonly used model reaction.[5][20]

### A. Catalyst Preparation and Pre-treatment

- Load a fixed amount of the ceria nanostructure catalyst into a fixed-bed reactor.
- Pre-treat the catalyst by heating it to a specific temperature (e.g., 120°C) under an inert gas flow (e.g., Argon) for a set duration (e.g., 1 hour) to remove any adsorbed impurities.[20]

### B. Catalytic Reaction

- Introduce a feed gas mixture with a defined composition (e.g., 3 vol% CO, 3 vol% O<sub>2</sub>, and 94 vol% Ar) into the reactor at a constant flow rate.[20]
- Ramp the reactor temperature at a controlled rate (e.g., 5°C/min) over the desired temperature range (e.g., 120-420°C).[20]
- Continuously monitor the composition of the effluent gas using an online gas chromatograph (GC) equipped with a suitable detector (e.g., TCD or FID).

### C. Data Analysis

- Calculate the CO conversion at each temperature point using the following formula: CO Conversion (%) =  $([\text{CO}]_{\text{in}} - [\text{CO}]_{\text{out}}) / [\text{CO}]_{\text{in}} * 100$
- Plot the CO conversion as a function of temperature to obtain the light-off curve.
- The temperature at which 50% CO conversion is achieved (T<sub>50</sub>) is a common metric for comparing the catalytic activity of different materials.[20] A lower T<sub>50</sub> indicates higher catalytic activity.

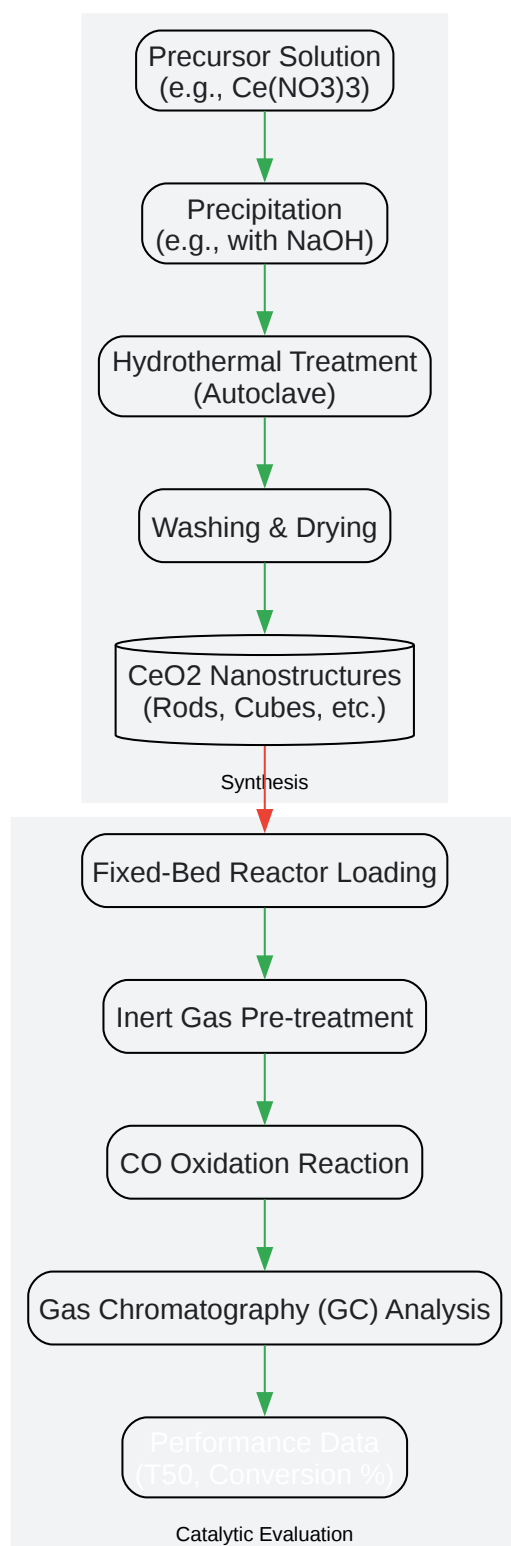

Figure 3: Workflow for synthesis and catalytic evaluation.

[Click to download full resolution via product page](#)

Caption: Workflow for synthesis and catalytic evaluation.

## Conclusion

The catalytic activity of cerium oxide nanostructures is unequivocally dependent on their morphology. Nanorods and nanocubes, with their higher proportion of reactive {110} and {100} facets, generally outperform spherical nanoparticles that predominantly expose the more stable {111} planes. This enhanced activity is primarily due to a higher concentration of easily formed oxygen vacancies, which are the key active sites in many oxidation reactions. For researchers and professionals in drug development and catalysis, a deep understanding of this structure-activity relationship is paramount for the rational design of next-generation, high-performance catalysts. By carefully controlling the synthesis conditions to favor the formation of specific nanostructures, it is possible to tune the catalytic properties of ceria to meet the demands of various applications.

## References

- Synthesis of Cerium Oxide (CeO<sub>2</sub>) nanoparticles using simple CO-precipitation method. (2016). *Revista Mexicana de Física*. Available at: [\[Link\]](#)
- Advancing the Understanding of Oxygen Vacancies in Ceria: Insights into Their Formation, Behavior, and Catalytic Roles. (2025). *JACS Au*. Available at: [\[Link\]](#)
- Revealing the Crystal Facet Effect of Ceria in Pd/CeO<sub>2</sub> Catalysts toward the Selective Oxidation of Benzyl Alcohol. (2023). *ACS Catalysis*. Available at: [\[Link\]](#)
- Critical Roles of Surface Oxygen Vacancy in Heterogeneous Catalysis over Ceria-based Materials: A Selected Review. (2021). *Chemistry Letters*. Available at: [\[Link\]](#)
- Ceria Catalysts at Nanoscale: How Do Crystal Shapes Shape Catalysis? (n.d.). *UPCommons*. Available at: [\[Link\]](#)
- Evolution of Oxygen Vacancy Sites in Ceria-Based High-Entropy Oxides and Their Role in N<sub>2</sub> Activation. (n.d.). *PMC*. Available at: [\[Link\]](#)
- Cerium Oxide Nanozymes: Exploring Synthesis, Catalytic Activity, and Biomedical Potential. (2025). *Advanced Materials*. Available at: [\[Link\]](#)

- Synthesis and Characterization of Cerium Oxide Nanoparticles: Effect of Cerium Precursor to Gelatin Ratio. (2023). MDPI. Available at: [\[Link\]](#)
- Synthesis of Cerium Oxide Nanoparticles Using Various Methods: Implications for Biomedical Applications. (n.d.). PMC. Available at: [\[Link\]](#)
- Synthesis of CeO<sub>2</sub> Nanoparticles by Various Methods. (2021). Arabian Journal of Chemical and Environmental Research. Available at: [\[Link\]](#)
- SYNTHESIS AND CHARACTER OF CERIUM OXIDE (CeO ) NANOPARTICLES BY THE PRECIPITATION METHOD. (n.d.). CORE. Available at: [\[Link\]](#)
- Revealing the Crystal Facet Effect of Ceria in Pd/CeO<sub>2</sub> Catalysts toward the Selective Oxidation of Benzyl Alcohol. (2023). ACS Publications. Available at: [\[Link\]](#)
- The design and optimization of heterogeneous catalysts using computational methods. (2023). Reaction Chemistry & Engineering. Available at: [\[Link\]](#)
- Catalytic activity of cerium oxide nanoparticles. (2016). Proceedings of the SPIE. Available at: [\[Link\]](#)
- Effect of oxygen vacancies on ceria catalyst for selective catalytic reduction of NO with NH<sub>3</sub>. (2020). Applied Surface Science. Available at: [\[Link\]](#)
- Crystal Plane Effect of Ceria on Supported Copper Oxide Cluster Catalyst for CO Oxidation: Importance of Metal–Support Interaction. (2017). ACS Catalysis. Available at: [\[Link\]](#)
- Cerium oxide nanostructures: properties, biomedical applications and surface coatings. (n.d.). Inorganic and Nano-Metal Chemistry. Available at: [\[Link\]](#)
- Study on the CO Oxidation over Ceria-Based Nanocatalysts. (2016). PMC. Available at: [\[Link\]](#)
- Promoting surface oxygen vacancies on ceria via light pretreatment to enhance catalytic ozonation. (n.d.). Catalysis Science & Technology. Available at: [\[Link\]](#)

- Spontaneous Self-Assembly of Cerium Oxide Nanoparticles to Nanorods through Supraaggregate Formation. (2005). The Journal of Physical Chemistry B. Available at: [\[Link\]](#)
- Adsorption and Oxidation of CO on Ceria Nanoparticles Exposing Single-Atom Pd and Ag: A DFT Modelling. (2021). Catalysts. Available at: [\[Link\]](#)
- Ceria crystal facet impact for methane C–H activation in Pd/CeO<sub>2</sub> catalysts. (n.d.). Catalysis Science & Technology. Available at: [\[Link\]](#)
- Synthesis and Catalytic Activity of Nanostructured Cerium Oxide. (n.d.). ResearchGate. Available at: [\[Link\]](#)
- What Changes on the Inverse Catalyst? Insight From CO Oxidation on Au-Supported Ceria Nanoparticles Using Ab Initio. (n.d.). ChemRxiv. Available at: [\[Link\]](#)
- Catalytic properties and biomedical applications of cerium oxide nanoparticles. (n.d.). KAUST Repository. Available at: [\[Link\]](#)
- Carbon Monoxide Oxidation on Ceria-Supported Nanoclusters. (2023). ACS Applied Materials & Interfaces. Available at: [\[Link\]](#)
- Microwave-assisted preparation of cerium dioxide nanocubes. (n.d.). ResearchGate. Available at: [\[Link\]](#)
- Improved CO Oxidation via Surface Stabilization of Ceria Nanoparticles Induced by Rare-Earth Metal Dopants. (n.d.). ACS Publications. Available at: [\[Link\]](#)
- Research and Developments of Heterogeneous Catalytic Technologies. (n.d.). PMC. Available at: [\[Link\]](#)
- Assessment of the Catalytic Performance of a Heterogeneous Fe<sub>2</sub>C Catalyst in the Formation of Multicarbon Products from Carbon Dioxide. (2023). ACS Publications. Available at: [\[Link\]](#)
- Controlled Synthesis and Self-Assembly of CeO<sub>2</sub> Nanocubes. (2006). Journal of the American Chemical Society. Available at: [\[Link\]](#)

- Synthesis and Characterization of Nano Cerium Oxide Using Hydrothermal Technique. (2021). ResearchGate. Available at: [\[Link\]](#)
- UNDERSTANDING THE STRUCTURE-PERFORMANCE RELATIONSHIP OF HETEROGENEOUS CATALYSTS FOR ENERGY PRODUCTION. (2021). Purdue University Graduate School. Available at: [\[Link\]](#)
- Synthesis of cerium oxide nanorods. (2016). Google Patents.
- How to Measure the Reaction Performance of Heterogeneous Catalytic Reactions Reliably. (n.d.). ResearchGate. Available at: [\[Link\]](#)

### Need Custom Synthesis?

BenchChem offers custom synthesis for rare earth carbides and specific isotopic labeling.

Email: [info@benchchem.com](mailto:info@benchchem.com) or [Request Quote Online](#).

## Sources

- [1. researchgate.net \[researchgate.net\]](https://www.researchgate.net)
- [2. pubs.acs.org \[pubs.acs.org\]](https://pubs.acs.org)
- [3. Evolution of Oxygen Vacancy Sites in Ceria-Based High-Entropy Oxides and Their Role in N2 Activation - PMC \[pmc.ncbi.nlm.nih.gov\]](https://pubmed.ncbi.nlm.nih.gov/31111111/)
- [4. upcommons.upc.edu \[upcommons.upc.edu\]](https://www.upcommons.org)
- [5. Study on the CO Oxidation over Ceria-Based Nanocatalysts - PMC \[pmc.ncbi.nlm.nih.gov\]](https://pubmed.ncbi.nlm.nih.gov/31111111/)
- [6. pubs.acs.org \[pubs.acs.org\]](https://pubs.acs.org)
- [7. academic.oup.com \[academic.oup.com\]](https://academic.oup.com)
- [8. pubs.acs.org \[pubs.acs.org\]](https://pubs.acs.org)
- [9. diposit.ub.edu \[diposit.ub.edu\]](https://diposit.ub.edu)
- [10. Cerium Oxide Nanozymes: Exploring Synthesis, Catalytic Activity, and Biomedical Potential - PubMed \[pubmed.ncbi.nlm.nih.gov\]](https://pubmed.ncbi.nlm.nih.gov/31111111/)
- [11. elar.ufrj.br \[elar.ufrj.br\]](https://elar.ufrj.br)
- [12. siruianogroup.com \[siruianogroup.com\]](https://siruianogroup.com)

- 13. Ceria crystal facet impact for methane C–H activation in Pd/CeO<sub>2</sub> catalysts - Catalysis Science & Technology (RSC Publishing) [pubs.rsc.org]
- 14. pmc.ncbi.nlm.nih.gov [pmc.ncbi.nlm.nih.gov]
- 15. pubs.acs.org [pubs.acs.org]
- 16. mocoed.es [mocoed.es]
- 17. US9738541B2 - Synthesis of cerium oxide nanorods - Google Patents [patents.google.com]
- 18. Synthesis of Cerium Oxide (CeO<sub>2</sub>) nanoparticles using simple CO-precipitation method [scielo.org.mx]
- 19. files01.core.ac.uk [files01.core.ac.uk]
- 20. pubs.acs.org [pubs.acs.org]
- To cite this document: BenchChem. [A Comparative Guide to the Catalytic Activity of Cerium Oxide Nanostructures]. BenchChem, [2026]. [Online PDF]. Available at: [https://www.benchchem.com/product/b8101794/docs#a-comparative-guide-to-the-catalytic-activity-of-cerium-oxide-nanostructures]

---

#### Disclaimer & Data Validity:

The information provided in this document is for Research Use Only (RUO) and is strictly not intended for diagnostic or therapeutic procedures. While BenchChem strives to provide accurate protocols, we make no warranties, express or implied, regarding the fitness of this product for every specific experimental setup.

**Technical Support:** The protocols provided are for reference purposes. Unsure if this reagent suits your experiment?

**Need Industrial/Bulk Grade?** [Request Custom Synthesis Quote](#)

# BenchChem

Our mission is to be the trusted global source of essential and advanced chemicals, empowering scientists and researchers to drive progress in science and industry.

## Contact

Address: 3281 E Guasti Rd

Ontario, CA 91761, United States

Phone: (601) 213-4426

Email: [info@benchchem.com](mailto:info@benchchem.com)

[Contact our Ph.D. Support Team for a compatibility check](#)