

Application Note: 2-Methoxyethyl Chloroacetate in Protecting Group Strategies and Enzymatic Resolution

Author: BenchChem Technical Support Team. **Date:** May 2026

Compound of Interest

Compound Name: 2-Methoxyethyl Chloroacetate

CAS No.: 13361-36-9

Cat. No.: B081098

[Get Quote](#)

Abstract

2-Methoxyethyl chloroacetate is a bifunctional reagent primarily utilized in organic synthesis for the introduction of the Chloroacetyl (ClAc) protecting group via enzymatic transesterification and as an electrophile for N-alkylation in heterocyclic chemistry. Unlike standard acyl donors (e.g., vinyl chloroacetate), this reagent offers unique solubility profiles and equilibrium thermodynamics suitable for sensitive kinetic resolutions. This guide details the mechanistic basis, experimental protocols, and safety considerations for its use, explicitly distinguishing it from the 2-methoxyethoxymethyl (MEM) ether protecting group reagents.

Technical Profile & Chemical Identity

Property	Specification
IUPAC Name	2-Methoxyethyl 2-chloroacetate
CAS Number	3278-89-5
Formula	C ₅ H ₉ ClO ₃
MW	152.58 g/mol
Structure	Cl-CH ₂ -C(=O)-O-CH ₂ -CH ₂ -O-CH ₃
Primary Function	Acyl Donor (Chloroacetylation), Alkylating Agent
Key Advantage	Water-miscible leaving group (2-methoxyethanol); Tunable enzymatic kinetics

Critical Distinction: Reagent Specificity

Do not confuse with MEM-Chloride (MEM-Cl).

- MEM-Cl (2-Methoxyethoxymethyl chloride): Used to protect alcohols as MEM ethers.[1]
- **2-Methoxyethyl Chloroacetate**: Used to protect alcohols/amines as Chloroacetates or to introduce the methoxyethoxycarbonylmethyl motif.

Mechanism of Action

Mode A: Enzymatic Chloroacetylation (Protecting Group Introduction)

In biocatalysis, **2-methoxyethyl chloroacetate** acts as an acyl donor. Lipases (e.g., *Candida antarctica* Lipase B, CAL-B) catalyze the transfer of the chloroacetyl group to a nucleophilic substrate (alcohol or amine).

- Why use it? Unlike vinyl esters, which release unstable acetaldehyde (enzyme deactivator), **2-methoxyethyl chloroacetate** releases 2-methoxyethanol. This leaving group is stable, non-reactive toward lysine residues on enzymes, and easily removed via aqueous wash due to its high water solubility.

Mode B: Nucleophilic Substitution (N-Alkylation)

The reagent contains an

-halo carbonyl moiety, making it a potent electrophile for SN2 reactions. It is used to alkylate acidic nitrogens (e.g., saccharin, amides) to attach the -CH₂COOCH₂CH₂OMe linker.

Graphviz Pathway Visualization

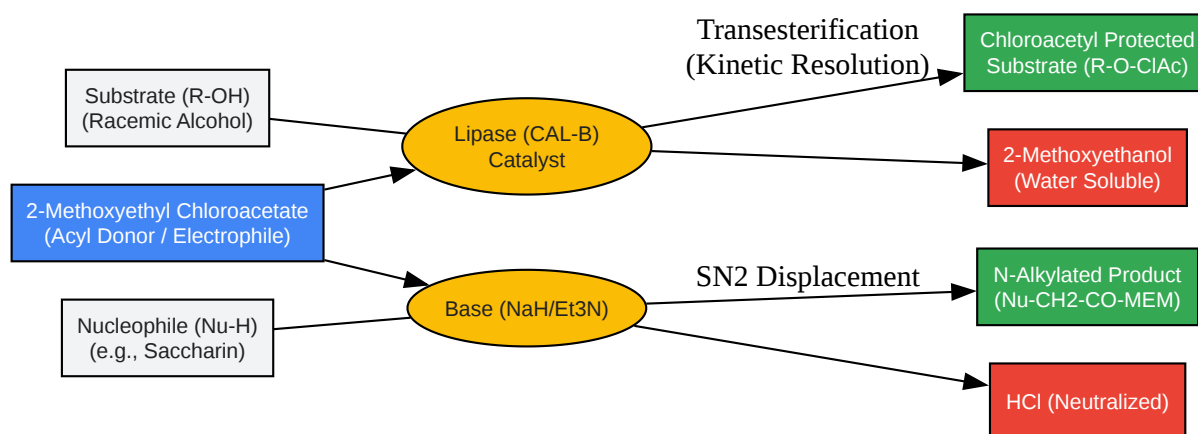

[Click to download full resolution via product page](#)

Caption: Dual reactivity pathways: Enzymatic transesterification (top) vs. Chemical alkylation (bottom).

Experimental Protocols

Protocol A: Enzymatic Introduction of Chloroacetyl Protecting Group

Application: Kinetic resolution of secondary alcohols or mild protection of labile substrates.

Reagents:

- Substrate: Racemic Alcohol (10 mmol)

- Reagent: **2-Methoxyethyl chloroacetate** (5-10 mmol, 0.5-1.0 eq depending on resolution vs protection)
- Catalyst: CAL-B (Novozym 435), 20 mg/mmol
- Solvent: Toluene or DIPE (Dry)

Step-by-Step Procedure:

- Preparation: Dissolve the racemic alcohol (10 mmol) in anhydrous Toluene (50 mL).
- Addition: Add **2-Methoxyethyl chloroacetate** (5 mmol for resolution, 12 mmol for full protection).
- Initiation: Add immobilized Lipase (200 mg).
- Incubation: Incubate at 30–40°C with orbital shaking (200 rpm). Monitor conversion via GC or HPLC.
 - Note: For kinetic resolution, stop reaction at 50% conversion.
- Termination: Filter off the enzyme beads.
- Workup: Wash the organic filtrate with water (3 x 20 mL) to remove the released 2-methoxyethanol.
- Purification: Concentrate the organic phase. Separate the Chloroacetyl ester from the unreacted alcohol via silica gel chromatography.

Protocol B: Deprotection of Chloroacetyl Groups

Principle: The Chloroacetyl (ClAc) group is orthogonal to acid/base labile groups and is cleaved by nucleophiles.

Reagents:

- Thiourea (1.2 eq)
- Solvent: Ethanol/Pyridine (1:1) or DMF[2]

Procedure:

- Dissolve the ClAc-protected substrate in Ethanol.
- Add Thiourea (1.2 equivalents).
- Heat to reflux for 1–2 hours. The reaction forms a pseudothiohydantoin byproduct.
- Cool and partition between water and ethyl acetate. The product (alcohol/amine) resides in the organic layer; the byproduct is water-soluble.

Protocol C: Synthesis of N-Alkylated Scaffolds (Piroxicam Intermediate Type)

Application: Attaching the methoxyethoxycarbonylmethyl linker.

Procedure:

- Salt Formation: Suspend the heterocycle (e.g., Saccharin, 10 mmol) in DMF. Add NaH (11 mmol, 60% dispersion) at 0°C. Stir until evolution of H₂ ceases.
- Alkylation: Add **2-Methoxyethyl chloroacetate** (11 mmol) dropwise.
- Reaction: Warm to room temperature and stir for 4–6 hours.
- Quench: Pour into ice water. The product often precipitates or can be extracted with DCM.

Scope and Limitations

Parameter	Performance Notes
Chemoselectivity	High. Lipases prefer primary > secondary alcohols. Does not react with phenols under enzymatic conditions.
Stability	The reagent is stable at room temperature but moisture-sensitive (hydrolysis to chloroacetic acid).
Solubility	Excellent in polar organic solvents. The byproduct (2-methoxyethanol) simplifies aqueous workup compared to methyl/ethyl esters.
Toxicity	High Hazard. Chloroacetates are strong alkylators (blistering agents). 2-Methoxyethanol is a reproductive toxin. Use double-gloving and fume hood.

References

- Use of chloroacetate esters in lipase-catalyzed resolution.
- Piroxicam Synthesis (Alkylation Application)
 - Synthetic method and intermediate for piroxicam.[3] (US Patent 4289879A). Describes the reaction of saccharin sodium salt with **2-methoxyethyl chloroacetate**.
- General Protecting Group Methodology: Greene, T.W., Wuts, P.G.M. Protective Groups in Organic Synthesis. Wiley-Interscience. (Standard reference for Chloroacetyl cleavage conditions).
- Reagent Data
 - Sigma-Aldrich/Merck Technical Data Sheet for 2-Methoxyethyl chloroacet

Disclaimer: This protocol is for research purposes only. Always consult the Safety Data Sheet (SDS) before handling chloroacetylating agents.

Need Custom Synthesis?

BenchChem offers custom synthesis for rare earth carbides and specific isotopic labeling.

Email: info@benchchem.com or [Request Quote Online](#).

Sources

- [1. 2-Methoxyethoxymethyl chloride - Wikipedia \[en.wikipedia.org\]](#)
- [2. researchgate.net \[researchgate.net\]](#)
- [3. EP0049099A2 - Synthetic method and intermediate for piroxicam - Google Patents \[patents.google.com\]](#)
- To cite this document: BenchChem. [Application Note: 2-Methoxyethyl Chloroacetate in Protecting Group Strategies and Enzymatic Resolution]. BenchChem, [2026]. [Online PDF]. Available at: [<https://www.benchchem.com/product/b081098/docs#application-note-2-methoxyethyl-chloroacetate-in-protecting-group-strategies-and-enzymatic-resolution>]

Disclaimer & Data Validity:

The information provided in this document is for Research Use Only (RUO) and is strictly not intended for diagnostic or therapeutic procedures. While BenchChem strives to provide accurate protocols, we make no warranties, express or implied, regarding the fitness of this product for every specific experimental setup.

Technical Support: The protocols provided are for reference purposes. Unsure if this reagent suits your experiment?

Need Industrial/Bulk Grade? [Request Custom Synthesis Quote](#)

BenchChem

Our mission is to be the trusted global source of essential and advanced chemicals, empowering scientists and researchers to drive progress in science and industry.

Contact

Address: 3281 E Guasti Rd

Ontario, CA 91761, United States

Phone: (601) 213-4426

Email: info@benchchem.com

[Contact our Ph.D. Support Team for a compatibility check](#)