

Technical Support Center: Phenylglycine Epimerization in SPPS

Author: BenchChem Technical Support Team. **Date:** April 2026

Compound of Interest

Compound Name: *(r)-a-(Fmoc-amino)-3-hydroxy-benzeneacetic acid*

Cat. No.: B8096289

[Get Quote](#)

Prepared by the Office of the Senior Application Scientist

Welcome to the technical support guide for managing the stereochemical integrity of phenylglycine (Phg) residues during Solid-Phase Peptide Synthesis (SPPS). Phenylglycine and its derivatives are invaluable building blocks in medicinal chemistry, often found in antimicrobial peptides and protease inhibitors. However, their synthesis is frequently complicated by a high propensity for epimerization, a side reaction that can compromise the purity, structure, and biological activity of the final peptide.

This guide is designed for researchers, chemists, and drug development professionals. It provides in-depth, evidence-based answers to common challenges, troubleshooting strategies for when things go wrong, and validated protocols to ensure your success.

Section 1: The "Why" - Understanding the Mechanism of Phenylglycine Epimerization

A foundational understanding of the underlying chemical principles is the first step toward effective troubleshooting and prevention.

Q1: Why is the phenylglycine residue uniquely susceptible to epimerization during SPPS?

A: The susceptibility of phenylglycine to epimerization stems from the electronic properties of its side chain. Unlike proteinogenic aromatic amino acids like phenylalanine, which has a flexible $-\text{CH}_2-$ spacer, the phenyl ring in Phg is directly attached to the α -carbon. This has a critical consequence:

The α -proton (the hydrogen attached to the chiral center) becomes significantly more acidic. The adjacent phenyl ring acts as an electron-withdrawing group, stabilizing the carbanion intermediate that forms when a base abstracts this proton.^[1] This stabilization occurs through resonance, delocalizing the negative charge across the aromatic system. Because this planar, achiral intermediate is readily formed, subsequent re-protonation can occur from either face, leading to a mixture of L- and D-isomers (epimerization).

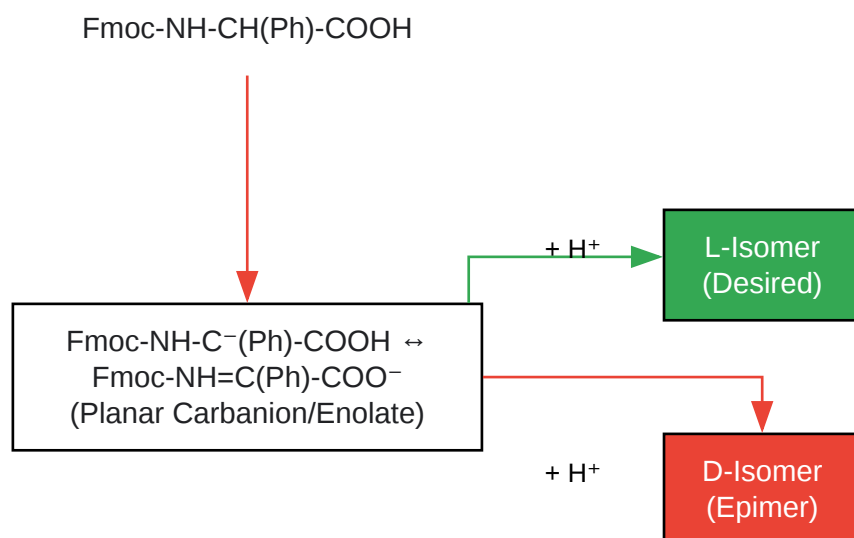

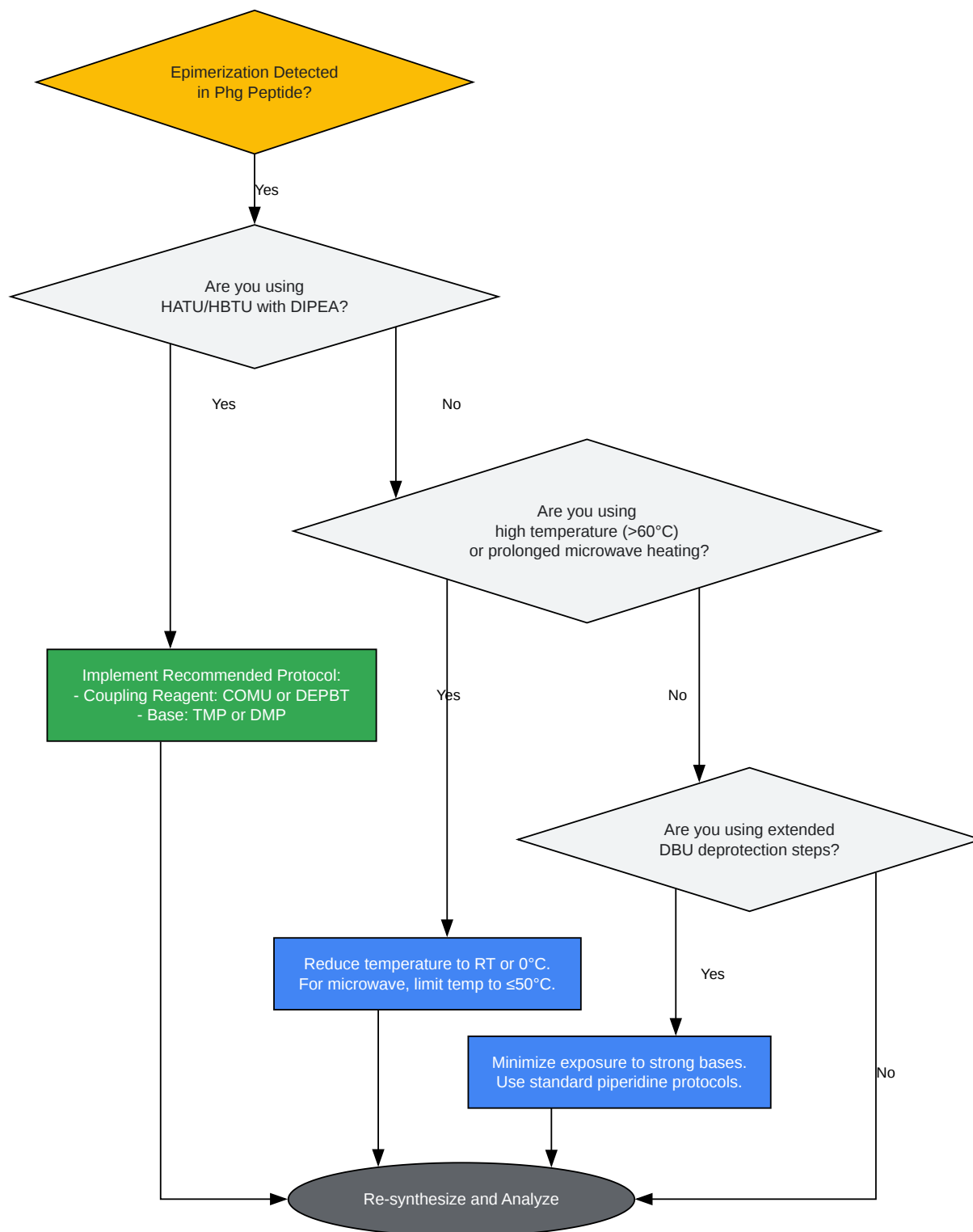

[Click to download full resolution via product page](#)

Caption: Troubleshooting workflow for Phg epimerization.

Q4: Does reaction temperature or pre-activation time affect epimerization?

A: Yes, both are important factors.

- Temperature: Higher temperatures accelerate all reaction rates, including the rate of proton abstraction and epimerization. [2] If you are experiencing issues, performing the coupling of the Phg residue at a lower temperature (e.g., 0°C) can be beneficial. For microwave-assisted SPPS, it is crucial to carefully control the temperature, as excessive heating can exacerbate epimerization. [3][4][5]* Pre-activation Time: Allowing the Fmoc-Phg-OH to sit in the basic activation mixture for an extended period before adding it to the resin can significantly increase epimerization. [6] The activated species is highly susceptible to base-mediated epimerization. Therefore, pre-activation should be kept to a minimum (1-2 minutes) or, ideally, the coupling reagents should be added directly to the resin vessel containing the amino acid (in-situ activation). [2]

Section 3: Validated Protocols & Best Practices

To ensure success from the outset, follow these validated protocols for incorporating phenylglycine and analyzing the outcome.

Protocol 1: Recommended Coupling Protocol for Fmoc-Phg-OH using COMU/TMP

This protocol is designed to minimize epimerization during the critical coupling step.

Materials:

- Fmoc-deprotected peptide-resin
- Fmoc-L-Phg-OH (3 eq.)
- COMU (3 eq.)
- TMP (6 eq.)
- Anhydrous N,N-Dimethylformamide (DMF)

Procedure:

- **Resin Preparation:** Swell the resin in DMF. Perform standard Fmoc deprotection of the N-terminal amino acid (e.g., 20% piperidine in DMF, 2 x 10 min). Wash the resin thoroughly with DMF (6-8 times) to remove all residual piperidine.
- **Amino Acid Solution:** In a separate vessel, dissolve Fmoc-L-Phg-OH (3 eq.) and COMU (3 eq.) in a minimal amount of anhydrous DMF.
- **Coupling Reaction (In-situ):** a. Add the Fmoc-L-Phg-OH/COMU solution to the drained, washed resin. b. Immediately add TMP (6 eq.) to the reaction vessel. c. Agitate the reaction mixture at room temperature for 1-2 hours.
- **Monitoring:** Perform a Kaiser test to confirm reaction completion. A negative (yellow) result indicates a successful coupling.
- **Washing:** Once the reaction is complete, drain the reaction vessel and wash the resin thoroughly with DMF (5-6 times) to remove excess reagents and byproducts.
- **Continuation:** Proceed with the Fmoc deprotection for the next cycle.

Protocol 2: Analytical Workflow for Quantifying Epimerization by RP-HPLC

This protocol provides a general method for cleaving the peptide and analyzing the crude product to determine the ratio of desired product to its diastereomer.

Procedure:

- **Peptide Cleavage:** After completing the synthesis, wash the peptide-resin with DCM and dry it under vacuum. Cleave the peptide from the resin using a standard cleavage cocktail (e.g., 95% TFA, 2.5% TIS, 2.5% H₂O) for 2-3 hours at room temperature.
- **Peptide Precipitation:** Precipitate the crude peptide in cold diethyl ether. Centrifuge to pellet the peptide, decant the ether, and repeat the ether wash twice. Dry the peptide pellet under vacuum.

- **Sample Preparation:** Dissolve a small amount of the crude peptide in a suitable solvent (e.g., 50% Acetonitrile/H₂O with 0.1% TFA) to a concentration of approximately 1 mg/mL.
- **HPLC Analysis:** a. Column: Use a standard C18 analytical RP-HPLC column. b. Mobile Phase A: 0.1% TFA in H₂O. c. Mobile Phase B: 0.1% TFA in Acetonitrile. d. Gradient: Run a linear gradient appropriate for your peptide's hydrophobicity (e.g., 5% to 65% B over 30 minutes). e. Detection: Monitor the elution profile at 220 nm.
- **Data Interpretation:** The desired peptide and its diastereomer will typically appear as two closely eluting peaks. Integrate the peak areas of both species to calculate the percentage of epimerization. Mass spectrometry should be used to confirm that both peaks have the identical mass corresponding to the target peptide. [3][4]

Section 4: Frequently Asked Questions (FAQs)

Q: Are phenylglycine derivatives, like 4-hydroxyphenylglycine (Hpg), also prone to epimerization? A: Yes, though the electronic nature of the substituent on the phenyl ring can influence the rate. Electron-donating groups (like -OH) can slightly decrease the rate of epimerization by destabilizing the carbanion intermediate, while electron-withdrawing groups (like -NO₂) can dramatically increase it. However, the same precautions should be taken for all phenylglycine-type residues.

Q: Is the resin-bound peptide at risk of epimerizing during subsequent, long coupling steps? A: The risk is significantly lower for an internal Phg residue compared to the activated Fmoc-Phg-OH being coupled. [7]The α -proton of a residue within a peptide chain is less acidic. However, prolonged exposure to very strong bases (e.g., 1% DBU in DMF overnight) can induce some epimerization on the resin. [7]Under standard SPPS conditions, this is generally not a major concern.

Q: My HPLC shows two peaks of identical mass. How can I be certain it's epimerization at the Phg residue and not at another amino acid? A: While other amino acids like Cys and His are also known to be susceptible to racemization, Phg is one of the most prone. [2]To definitively prove the site of epimerization, you can synthesize an analogue peptide where the Phg is replaced by Alanine. If this control peptide elutes as a single peak under identical synthesis and analysis conditions, it strongly implicates the Phg residue as the site of epimerization. [3][4]

References

- Liang, X., et al. (2017). Phenylglycine racemization in Fmoc-based solid-phase peptide synthesis. Elsevier. Available at: [\[Link\]](#)
- Duengo, S., et al. (2023). Epimerisation in Peptide Synthesis. PMC. Available at: [\[Link\]](#)
- Erawy, M. A. A., et al. (2012). Racemisation of N-Fmoc phenylglycine under mild microwave-SPPS and conventional stepwise SPPS conditions: attempts to develop strategies for overcoming this. PubMed. Available at: [\[Link\]](#)
- Erawy, M. A. A., et al. (2012). Racemisation of >N>-Fmoc phenylglycine under mild microwave-SPPS and conventional stepwise SPPS conditions: Attempts to develop strategies for overcoming this. The University of Manchester Research Explorer. Available at: [\[Link\]](#)
- AAPPTEC. (n.d.). Aggregation, Racemization and Side Reactions in Peptide Synthesis. AAPPTEC. Available at: [\[Link\]](#)
- Erawy, M. A. A., et al. (2012). Racemisation of N-Fmoc phenylglycine under mild microwave-SPPS and conventional stepwise SPPS conditions: Attempts to develop strategies for overcoming this. ResearchGate. Available at: [\[Link\]](#)
- Urban, J., et al. (2017). Enhanced Epimerization of Glycosylated Amino Acids During Solid Phase Peptide Synthesis. PMC. Available at: [\[Link\]](#)
- Kallscheuer, N., et al. (2015). Structural aspects of phenylglycines, their biosynthesis and occurrence in peptide natural products. RSC Publishing. Available at: [\[Link\]](#)
- CEM Corporation. (n.d.). Unparalleled Solid Phase Peptide Synthesis. CEM Corporation. Available at: [\[Link\]](#)
- Duengo, S., et al. (2023). Epimerisation in Peptide Synthesis. MDPI. Available at: [\[Link\]](#)
- Mesa Labs. (n.d.). SPPS Tips For Success Handout. Mesa Labs. Available at: [\[Link\]](#)
- Andrews, E. (2022). SYNTHETIC AND ANALYTICAL METHODS FOR METAL TARGETING PEPTIDES FOR THE. UNH Scholars Repository. Available at: [\[Link\]](#)

- El-Faham, A., & Albericio, F. (2011). Peptide Coupling Reagents, More than a Letter Soup. Chemical Reviews. Available at: [\[Link\]](#)

Need Custom Synthesis?

BenchChem offers custom synthesis for rare earth carbides and specific isotopic labeling.

Email: info@benchchem.com or [Request Quote Online](#).

Sources

- [1. Epimerisation in Peptide Synthesis - PMC \[pmc.ncbi.nlm.nih.gov\]](#)
- [2. cem.hu \[cem.hu\]](#)
- [3. research.manchester.ac.uk \[research.manchester.ac.uk\]](#)
- [4. researchgate.net \[researchgate.net\]](#)
- [5. peptide.com \[peptide.com\]](#)
- [6. benchchem.com \[benchchem.com\]](#)
- [7. luxembourg-bio.com \[luxembourg-bio.com\]](#)
- To cite this document: BenchChem. [Technical Support Center: Phenylglycine Epimerization in SPPS]. BenchChem, [2026]. [Online PDF]. Available at: [\[https://www.benchchem.com/product/b8096289/docs#technical-support-center-phenylglycine-epimerization-in-spps\]](https://www.benchchem.com/product/b8096289/docs#technical-support-center-phenylglycine-epimerization-in-spps)

Disclaimer & Data Validity:

The information provided in this document is for Research Use Only (RUO) and is strictly not intended for diagnostic or therapeutic procedures. While BenchChem strives to provide accurate protocols, we make no warranties, express or implied, regarding the fitness of this product for every specific experimental setup.

Technical Support: The protocols provided are for reference purposes. Unsure if this reagent suits your experiment?

Need Industrial/Bulk Grade? [Request Custom Synthesis Quote](#)

BenchChem

Our mission is to be the trusted global source of essential and advanced chemicals, empowering scientists and researchers to drive progress in science and industry.

Contact

Address: 3281 E Guasti Rd

Ontario, CA 91761, United States

Phone: (601) 213-4426

Email: info@benchchem.com

[Contact our Ph.D. Support Team for a compatibility check](#)