

Column chromatography techniques for separating quinolinium salt isomers

Author: BenchChem Technical Support Team. **Date:** April 2026

Compound of Interest

Compound Name: *3-Bromo-1-methylquinolin-1-ium;bromide*

Cat. No.: *B8093915*

[Get Quote](#)

Technical Support Center: Purification of Quinolinium Salt Isomers

Current Status: Operational Topic: Column Chromatography & Purification Strategies for Quinolinium Salts Support Level: Tier 3 (Senior Application Scientist)

Introduction: The "Sticky" Physics of Quinolinium Salts

User Query: "Why is my quinolinium salt sticking to the baseline or streaking across the entire column?"

Technical Insight: Quinolinium salts are permanently charged, cationic species. Standard silica gel (

) is acidic (

) due to surface silanol groups (

). When you load a cationic quinolinium salt onto untreated silica, it undergoes a strong ion-exchange interaction with the deprotonated silanols (

), effectively "gluing" your compound to the stationary phase.

To separate these isomers, you must suppress this ionic interaction and rely on polarity/shape selectivity. This guide details the Buffered Silica Method, Reverse-Phase Strategies, and the Counter-Ion Metathesis technique.

Module 1: Troubleshooting Tailing & Retention (Normal Phase)

Q: My compound streaks from the baseline to the solvent front. How do I fix this peak shape?

A: You must deactivate the silica surface using mobile phase modifiers.

Standard solvents (Hexane/EtOAc or DCM/MeOH) are insufficient because they do not compete for the active silanol sites. You need a "sacrificial" base or a high-ionic-strength buffer.

Protocol A: The "Buffered Silica" Method (Recommended)

This method creates a constant ionic environment, sharpening peaks significantly.

- Preparation: Prepare a stock solution of Ammonium Acetate () saturated in Methanol.
- Mobile Phase: Add this stock to your DCM (Dichloromethane) to achieve a final concentration of roughly 10-20 mM in the mobile phase.
 - Example: 90% DCM / 9% MeOH / 1% Saturated in MeOH.
- Mechanism: The ammonium ions () compete with your quinolinium cation for the silanol sites, while the acetate buffers the acidity.

Protocol B: The "Sacrificial Base" Method

Use this if you cannot use buffers due to solubility issues.

- Modifier: Add 1% Triethylamine (TEA) or 1% Ammonium Hydroxide () to both the column equilibration solvent and the elution solvent.

- Warning: TEA is difficult to remove from high-boiling salts.

is volatile but can degrade silica over long runs.

Data Comparison: Modifier Efficiency

Modifier Strategy	Peak Shape (Symmetry Factor)	Resolution (Rs)	Post-Run Workup
None (DCM/MeOH)	< 0.5 (Severe Tailing)	Poor (Co-elution)	N/A
1% TEA	0.9 - 1.1 (Sharp)	Good	High Vac / HCl Wash (Tedious)
10mM NH4OAc	1.0 (Excellent)	Excellent	Simple Evaporation

Module 2: Separating Regioisomers (6- vs 8-Substituted)

Q: I have a mixture of 6-bromo and 8-bromo quinolinium salts. They co-elute on silica. How do I separate them?

A: Silica is insufficient for regioisomers. Switch to Reversed-Phase (C18) or Phenyl-Hexyl phases.

Regioisomers often have identical polarity but different 3D shapes. Silica separates primarily by polarity. C18 (Octadecyl) separates by hydrophobicity and shape (steric hindrance).

The "Shape Selectivity" Workflow

- Stationary Phase: C18 (Reversed Phase) is the standard.[1] For difficult aromatic isomers, use a Phenyl-Hexyl column, which exploits interactions with the quinoline ring.
- Mobile Phase: Water / Acetonitrile (MeCN) with 0.1% Trifluoroacetic Acid (TFA).
 - Why TFA? It acts as an ion-pairing agent. The trifluoroacetate anion pairs with the quinolinium cation, making it more lipophilic and improving retention on the non-polar C18 chain.
- Gradient: Run a shallow gradient (e.g., 5% to 30% MeCN over 20 CVs).

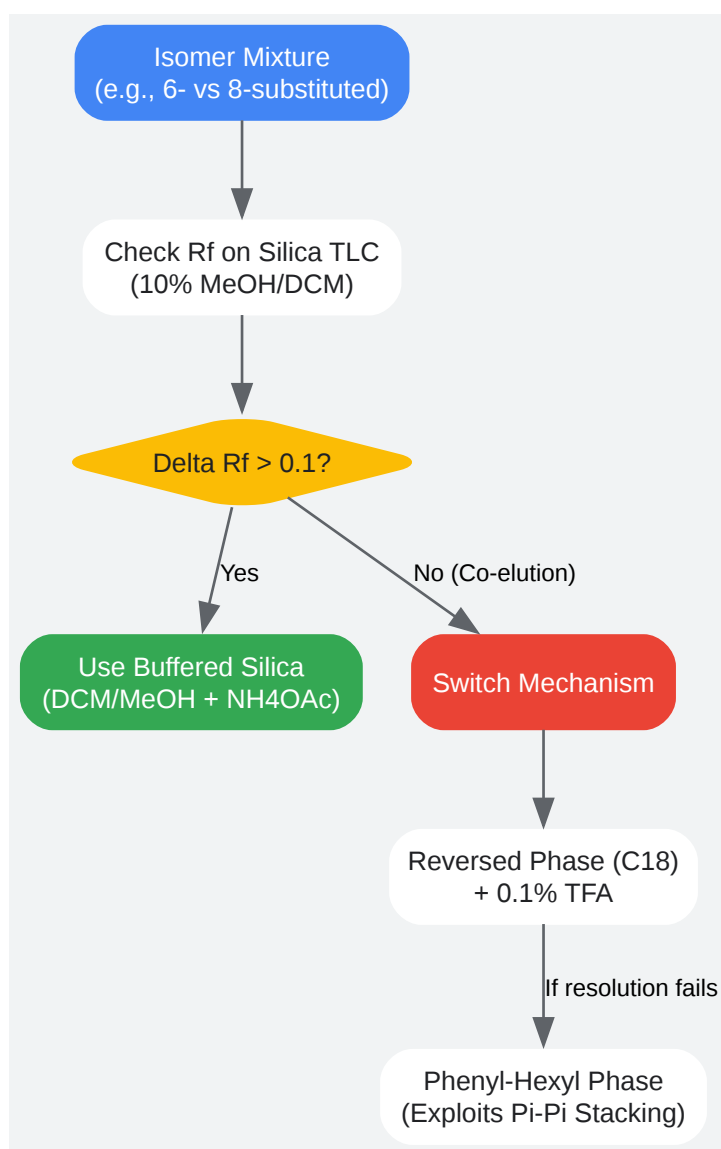

[Click to download full resolution via product page](#)

Caption: Decision tree for selecting the correct stationary phase based on isomer resolution.

Module 3: The "Nuclear Option" (Counter-Ion Metathesis)

Q: My salt is too polar for silica but not soluble enough for C18. What now?

A: Change the physics of the molecule by swapping the counter-ion.

Quinolinium halides (Cl, Br, I) are extremely polar. By swapping the halide for a bulky, lipophilic anion (like Hexafluorophosphate,

), you can make the salt soluble in organic solvents (DCM, EtOAc) and purifiable on standard silica without aggressive tailing.

Protocol: The Anion Swap Technique

- Metathesis: Dissolve your crude halide salt in minimal water. Add a saturated aqueous solution of

(Potassium Hexafluorophosphate) or

.
- Precipitation: The lipophilic quinolinium-salt will precipitate out of the water. Filter and dry.^[2]
- Purification: The new salt is now soluble in DCM/Acetone. Purify via standard flash chromatography (Silica).
- Restoration (Optional): If the halide is required for the final product, perform an ion-exchange using an Amberlite IRA-400 (Cl⁻ form) resin to swap the

back to

.

Module 4: Sample Loading (The Solubility Paradox)

Q: My sample precipitates at the top of the column when I inject it.

A: You are experiencing "Solvent Shock." Use Solid Loading.

Quinolinium salts often require Methanol or DMSO to dissolve, but these are "strong" solvents that ruin the chromatography if injected directly (causing band broadening).

Protocol: Solid (Dry) Loading

- Dissolution: Dissolve the crude mixture in the minimal amount of MeOH or Acetone required.
- Adsorption: Add Celite 545 (diatomaceous earth) or Silica Gel to the flask. Ratio: 2g solid support per 1g crude sample.
- Evaporation: Rotovap to dryness. You should have a free-flowing powder.
- Loading: Pour this powder into a solid load cartridge (or on top of the column bed) and pack it down.
- Elution: Start your gradient. The compound will elute as a tight band because it is not "chasing" a slug of strong solvent.

References

- Vertex AI Search. (2025). Separation of Quaternary Ammonium Compounds Using a Bonded Polymeric Zwitterionic Stationary Phase. LCGC International. [Link](#)
- Teledyne ISCO. (2023). Sample Loading Techniques for Large Scale Flash Chromatography. Teledyne ISCO Technical Notes. [Link](#)
- Sielc Technologies. (2024). Separation of Quinoline on Newcrom R1 HPLC column. Sielc Application Notes. [Link](#)
- BenchChem. (2025).[3] Purification Strategies for 2-Aminoquinoline Derivatives. Technical Support Center. [Link](#)

- Musil, P. et al. (2012). Preparation of Quinolinium Salts Differing in the Length of the Alkyl Side Chain. *Molecules*, 17, 6391.[4] [Link\[4\]](#)

Need Custom Synthesis?

BenchChem offers custom synthesis for rare earth carbides and specific isotopic labeling.

Email: info@benchchem.com or [Request Quote Online](#).

Sources

- 1. Don't get salty about your separations. Develop flash and prep HPLC applications to purify a range of compounds. | [Buchi.com](https://www.buchi.com) [[buchi.com](https://www.buchi.com)]
- 2. Preparation of Quinolinium Salts Differing in the Length of the Alkyl Side Chain - PMC [[pmc.ncbi.nlm.nih.gov](https://pubmed.ncbi.nlm.nih.gov/)]
- 3. pdf.benchchem.com [pdf.benchchem.com]
- 4. [researchgate.net](https://www.researchgate.net) [[researchgate.net](https://www.researchgate.net)]
- To cite this document: BenchChem. [Column chromatography techniques for separating quinolinium salt isomers]. BenchChem, [2026]. [Online PDF]. Available at: [<https://www.benchchem.com/product/b8093915/docs#column-chromatography-techniques-for-separating-quinolinium-salt-isomers>]

Disclaimer & Data Validity:

The information provided in this document is for Research Use Only (RUO) and is strictly not intended for diagnostic or therapeutic procedures. While BenchChem strives to provide accurate protocols, we make no warranties, express or implied, regarding the fitness of this product for every specific experimental setup.

Technical Support: The protocols provided are for reference purposes. Unsure if this reagent suits your experiment?

Need Industrial/Bulk Grade? [Request Custom Synthesis Quote](#)

BenchChem

Our mission is to be the trusted global source of essential and advanced chemicals, empowering scientists and researchers to drive progress in science and industry.

Contact

Address: 3281 E Guasti Rd

Ontario, CA 91761, United States

Phone: (601) 213-4426

Email: info@benchchem.com

[Contact our Ph.D. Support Team for a compatibility check](#)