

Biological activity potential of benzothiazole-6-yl scaffolds

Author: BenchChem Technical Support Team. **Date:** April 2026

Compound of Interest

Compound Name: *Tert-butyl 2-(benzo[d]thiazol-6-yl)acetate*

Cat. No.: B8090643

[Get Quote](#)

Title: The Pharmacophore Frontier: Unlocking the Biological Potential of Benzothiazole-6-yl Scaffolds[1]

Executive Summary

The benzothiazole moiety stands as a "privileged scaffold" in medicinal chemistry—a molecular framework capable of binding to diverse biological targets with high affinity. While the C-2 position has traditionally dominated structure-activity relationship (SAR) studies due to synthetic accessibility, the C-6 position (benzothiazole-6-yl) has emerged as a critical vector for modulating pharmacokinetics, metabolic stability, and target specificity.[1]

This technical guide dissects the benzothiazole-6-yl scaffold, shifting focus from general heterocyclic chemistry to the specific electronic and steric advantages provided by substitution at the 6-position.[1] We analyze its role in oncology (EGFR/kinase inhibition), infectious disease (DNA gyrase targeting), and neuroprotection, supported by rigorous experimental protocols and mechanistic visualizations.

Part 1: Structural Chemistry & SAR Logic

The "Magic" of Position 6

In the benzothiazole fused ring system, position 6 is para to the nitrogen atom and meta to the sulfur. This unique geometric and electronic positioning offers three distinct advantages for drug design:

- **Metabolic Blockade:** The C-6 position is a primary site for oxidative metabolism (hydroxylation) by Cytochrome P450 enzymes.^[1] Substituting this position (e.g., with -F, -Cl, -OCF₃) blocks this metabolic soft spot, significantly extending the drug's half-life ().
- **Electronic Tuning:** Substituents at C-6 communicate electronically with the N-3 nitrogen, which is often the key hydrogen bond acceptor in kinase active sites.^[1]
 - **Electron-Withdrawing Groups (EWG)** (e.g., -NO₂, -CF₃) decrease the basicity of N-3, potentially strengthening hydrogen bonds with backbone amides in the ATP-binding pocket of kinases.^[1]
 - **Electron-Donating Groups (EDG)** (e.g., -OCH₃, -NH₂) increase electron density, useful for targets requiring charge-transfer interactions.^[1]
- **Lipophilic Vector:** The C-6 vector points into the "solvent-accessible" or "hydrophobic back pocket" of many enzyme active sites (like EGFR), allowing for bulkier substitutions without disrupting the core binding mode.^[1]

Visualization: SAR Optimization Logic

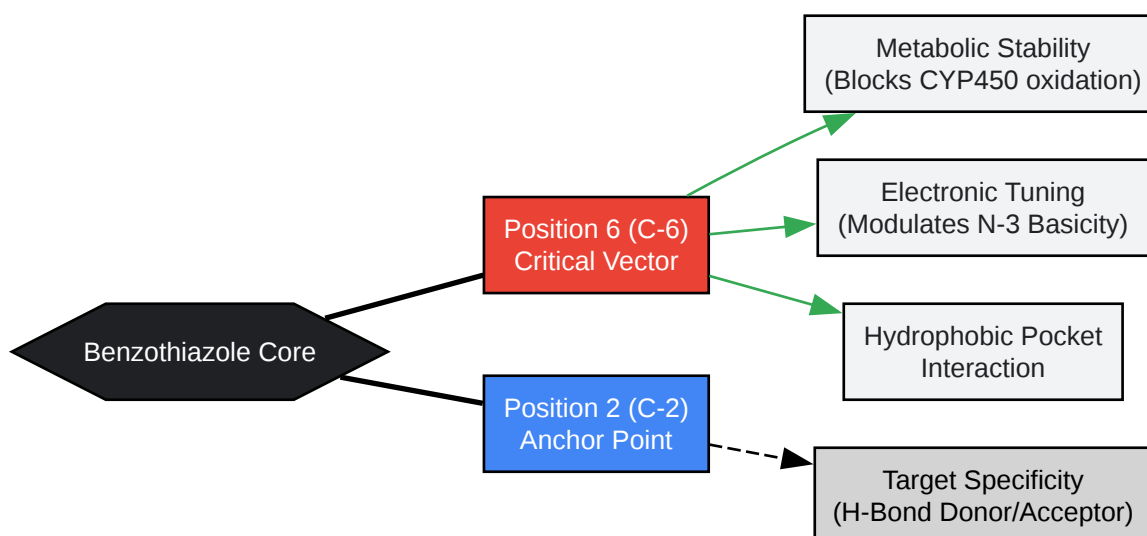

[Click to download full resolution via product page](#)

Figure 1: Strategic importance of the C-6 position in benzothiazole drug design. Unlike C-2 (often used for linking), C-6 dictates physicochemical properties and metabolic fate.[1]

Part 2: Therapeutic Applications & Mechanisms

Oncology: EGFR Tyrosine Kinase Inhibition

The most potent application of benzothiazole-6-yl derivatives is in the inhibition of Epidermal Growth Factor Receptor (EGFR).[1] The scaffold acts as a bioisostere of the adenine ring of ATP.

- Mechanism: The benzothiazole nitrogen (N-3) accepts a hydrogen bond from the hinge region of the kinase (specifically Met793 in EGFR), while the C-6 substituent extends into the hydrophobic pocket, displacing water and locking the enzyme in an inactive conformation.[1]
- Key Insight: 6-substituted derivatives (e.g., 6-chloro or 6-nitro) often show nanomolar IC50 values against non-small cell lung cancer (NSCLC) lines (A549, HCT-116) by preventing autophosphorylation of tyrosine residues.[1]

Visualization: EGFR Signaling Blockade

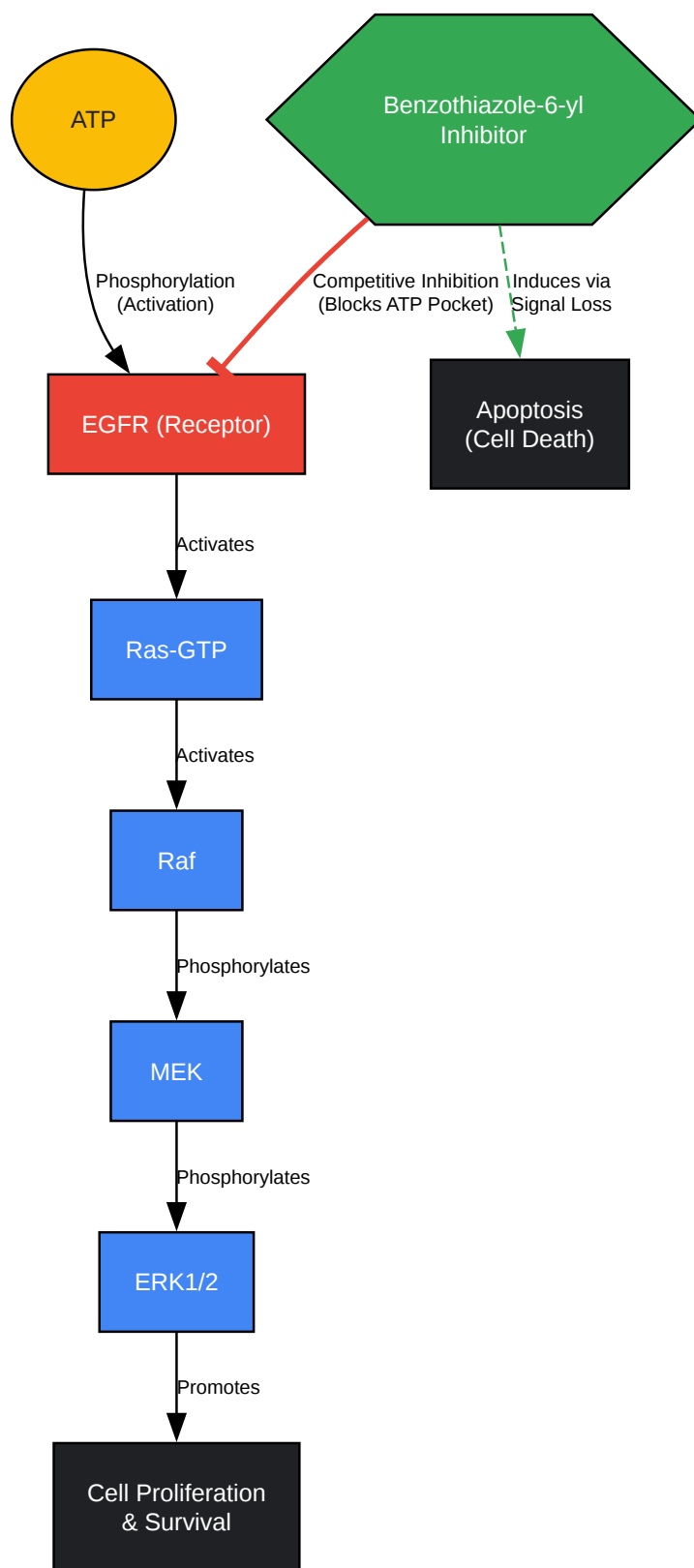

[Click to download full resolution via product page](#)

Figure 2: Mechanism of Action.[1] The benzothiazole-6-yl scaffold competes with ATP, shutting down the RAS/RAF/MEK/ERK cascade and forcing the cancer cell into apoptosis.

Infectious Disease: DNA Gyrase Inhibition

Benzothiazole-6-yl derivatives exhibit broad-spectrum antimicrobial activity, particularly against Gram-negative bacteria like *P. aeruginosa*.^[1]

- Target: DNA Gyrase (Subunit B).^[1]
- Mechanism: The scaffold stabilizes the cleavable complex between DNA and gyrase, preventing DNA religation and leading to the accumulation of double-strand breaks.
- SAR Note: Electron-withdrawing groups at C-6 (e.g., -F, -Cl) are crucial here. They enhance the lipophilicity required to penetrate the bacterial cell wall and improve binding affinity to the ATPase domain of gyrase.

Part 3: Experimental Protocols

Protocol A: Synthesis of 6-Substituted-2-Arylbenzothiazoles

Rationale: This protocol uses the oxidative condensation of 2-aminothiophenols with aldehydes.^[1] It is preferred over the Jacobson cyclization for its milder conditions and higher yields.

Materials:

- 2-Amino-5-chlorobenzenethiol (for 6-chloro derivative)^[1]
- Substituted Benzaldehyde (e.g., 4-methoxybenzaldehyde)^[1]
- Sodium Metabisulfite (

)^[1]
- DMSO (Solvent)^{[1][2]}

Step-by-Step Workflow:

- Reactant Prep: Dissolve 1.0 mmol of 2-amino-5-chlorobenzenethiol and 1.0 mmol of 4-methoxybenzaldehyde in 5 mL of DMSO.
- Catalyst Addition: Add 1.2 mmol of Sodium Metabisulfite.
- Reflux: Heat the mixture at 120°C for 2-4 hours. Monitor via TLC (Hexane:Ethyl Acetate 7:3).
[1]
- Quenching: Pour the reaction mixture into crushed ice/water.
- Isolation: Filter the precipitate, wash with cold water, and recrystallize from ethanol.
- Validation: Confirm structure via

-NMR. Look for the disappearance of the aldehyde proton (~10 ppm) and the thiol proton.[1]

Protocol B: In Vitro EGFR Kinase Inhibition Assay

Rationale: To quantify the potency (IC50) of the synthesized scaffold against the target enzyme.[1][3]

Reagents:

- Recombinant EGFR kinase domain.
- Poly(Glu,Tyr) 4:1 substrate.[1]
- ATP (10
M).[1]
- -ATP (Radioactive tracer) or ADP-Glo reagent (Luminescence).[1]

Methodology:

- Preparation: Dilute compounds in DMSO to varying concentrations (0.1 nM to 10
M).

- Incubation: Mix EGFR enzyme, peptide substrate, and compound in kinase buffer (50 mM HEPES, pH 7.5, 10 mM
). Incubate for 10 mins at 25°C.
- Initiation: Add ATP mixture to start the reaction.[4] Incubate for 30 mins.
- Termination: Stop reaction with 0.5% phosphoric acid (radioactive) or ADP-Glo termination buffer.
- Detection: Measure luminescence or scintillation counts.
- Analysis: Plot % Inhibition vs. Log[Concentration] to determine IC50 using non-linear regression.

Part 4: Quantitative Data Summary

Table 1: Comparative Biological Activity of 6-Substituted Benzothiazoles

Substitution (C-6)	Target	Cell Line / Organism	Activity (IC50 / MIC)	Key Property
-H (Unsubstituted)	EGFR Kinase	A549 (Lung)	12.5 M	Baseline activity; metabolically labile.[1]
-Cl (Chloro)	EGFR Kinase	A549 (Lung)	0.8 M	Enhanced lipophilicity; metabolic block. [1]
-OCF3 (Riluzole-like)	Glutamate	Neuroblastoma	2.1 M	CNS penetration; neuroprotective. [1]
-NO2 (Nitro)	DNA Gyrase	E. coli	4 g/mL	Strong H-bond acceptor; antimicrobial.[1]
-NH2 (Amino)	Tubulin	MCF-7 (Breast)	1.5 M	H-bond donor; pro-apoptotic.[1]

References

- Kaur, H. et al. (2024).[1][5] Scope of Benzothiazole Scaffold: A Review. International Journal of Biology, Pharmacy and Allied Sciences. [Link](#)
- Irfan, A. et al. (2020).[1][6] Benzothiazole derivatives as anticancer agents. Journal of Enzyme Inhibition and Medicinal Chemistry. [Link\[1\]](#)
- BenchChem. (2025).[4][7] Literature review of 6-substituted benzothiazole compounds. [Link\[1\]](#)
- Mishra, S. et al. (2023).[1][8] Recent insights into antibacterial potential of benzothiazole derivatives. Future Medicinal Chemistry. [Link](#)

- Refaat, H. et al. (2025). EGFR tyrosine kinase targeted compounds: in vitro antitumor activity. Journal of Applied Pharmaceutical Science. [Link](#)

Need Custom Synthesis?

BenchChem offers custom synthesis for rare earth carbides and specific isotopic labeling.

Email: info@benchchem.com or [Request Quote Online](#).

Sources

- 1. derpharmachemica.com [derpharmachemica.com]
- 2. pubs.acs.org [pubs.acs.org]
- 3. researchgate.net [researchgate.net]
- 4. pdf.benchchem.com [pdf.benchchem.com]
- 5. ijbpas.com [ijbpas.com]
- 6. researchgate.net [researchgate.net]
- 7. pdf.benchchem.com [pdf.benchchem.com]
- 8. Recent insights into antibacterial potential of benzothiazole derivatives - PMC [[pmc.ncbi.nlm.nih.gov](https://pubmed.ncbi.nlm.nih.gov)]
- To cite this document: BenchChem. [Biological activity potential of benzothiazole-6-yl scaffolds]. BenchChem, [2026]. [Online PDF]. Available at: [<https://www.benchchem.com/product/b8090643/docs#biological-activity-potential-of-benzothiazole-6-yl-scaffolds>]

Disclaimer & Data Validity:

The information provided in this document is for Research Use Only (RUO) and is strictly not intended for diagnostic or therapeutic procedures. While BenchChem strives to provide accurate protocols, we make no warranties, express or implied, regarding the fitness of this product for every specific experimental setup.

Technical Support: The protocols provided are for reference purposes. Unsure if this reagent suits your experiment?

Need Industrial/Bulk Grade? [Request Custom Synthesis Quote](#)

BenchChem

Our mission is to be the trusted global source of essential and advanced chemicals, empowering scientists and researchers to drive progress in science and industry.

Contact

Address: 3281 E Guasti Rd
Ontario, CA 91761, United States
Phone: (601) 213-4426
Email: info@benchchem.com

[Contact our Ph.D. Support Team for a compatibility check](#)