

2,4-Dibromo-5-chloropyrimidine: Technical Guide & Synthetic Utility

Author: BenchChem Technical Support Team. **Date:** April 2026

Compound of Interest

Compound Name: 2,4-Dibromo-5-chloropyrimidine

Cat. No.: B8089866

[Get Quote](#)

Chemical Identity & Physicochemical Profile

2,4-Dibromo-5-chloropyrimidine is a tri-halogenated pyrimidine scaffold.[1] Its value lies in the differential reactivity of its three halogen substituents, allowing for sequential, regioselective functionalization.[2] This "chemical programmability" makes it a critical building block for Structure-Activity Relationship (SAR) studies in drug discovery.

Core Data Table

Property	Detail
IUPAC Name	2,4-Dibromo-5-chloropyrimidine
CAS Number	1266480-96-9
Molecular Formula	C ₄ HBr ₂ ClN ₂
Molecular Weight	272.33 g/mol
Appearance	Off-white to pale yellow solid
Solubility	Soluble in DCM, DMSO, DMF; sparingly soluble in water
Storage	2–8°C, inert atmosphere (Argon/Nitrogen), moisture-sensitive

Structural Visualization

The molecule features a pyrimidine ring with bromine atoms at positions 2 and 4, and a chlorine atom at position 5.

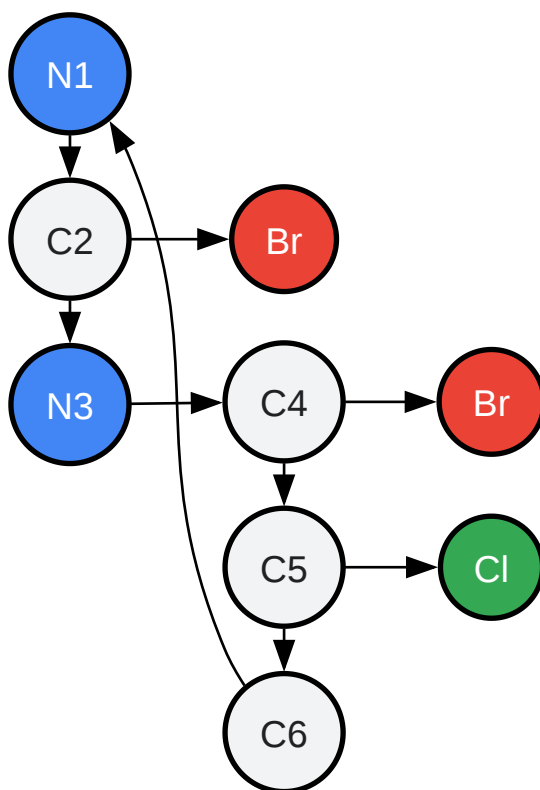

[Click to download full resolution via product page](#)

Figure 1: Connectivity of **2,4-Dibromo-5-chloropyrimidine** showing halogen substitution pattern.[1]

Synthesis Protocol

The synthesis of **2,4-Dibromo-5-chloropyrimidine** is typically achieved via the bromination of 5-chlorouracil. This route ensures the chlorine is pre-installed at the correct position before the ring is activated with bromine.

Step 1: Chlorination of Uracil

Objective: Install the chlorine atom at the C5 position.[3]

- Reagents: Uracil, N-Chlorosuccinimide (NCS), Acetic Acid.
- Mechanism: Electrophilic aromatic substitution. The C5 position of uracil is nucleophilic.
- Protocol:
 - Suspend Uracil (1.0 eq) in glacial acetic acid.
 - Heat to 50–60°C.
 - Add NCS (1.1 eq) portion-wise over 30 minutes.
 - Reflux for 2–4 hours.
 - Cool to room temperature; the product, 5-chlorouracil, precipitates.[4] Filter and wash with water.[3]

Step 2: Bromination to 2,4-Dibromo-5-chloropyrimidine

Objective: Convert the carbonyl oxygens at C2 and C4 into reactive bromine leaving groups.

- Reagents: 5-Chlorouracil, Phosphorus Oxybromide (POBr_3), N,N-Diethylaniline (catalyst).
- Protocol:

- Setup: Use a dry round-bottom flask with a reflux condenser and drying tube (moisture sensitive).
- Mix: Combine 5-chlorouracil (1.0 eq) with POBr₃ (3.0–4.0 eq).
- Catalysis: Add N,N-Diethylaniline (1.0 eq) dropwise.
- Reaction: Heat the neat mixture to 110–120°C for 4–6 hours. The solid slurry will melt and homogenize.
- Quench (Critical Safety): Cool to 0°C. Pour the reaction mixture slowly onto crushed ice with vigorous stirring. Caution: Exothermic hydrolysis of excess POBr₃ generates HBr gas.
- Extraction: Extract the aqueous mixture with Dichloromethane (DCM) (3x).
- Purification: Wash organic layer with saturated NaHCO₃, brine, dry over Na₂SO₄, and concentrate. Purify via flash column chromatography (Hexanes/EtOAc).

Reactivity & Regioselectivity

The utility of this scaffold is defined by the hierarchy of reactivity between the C4-Br, C2-Br, and C5-Cl sites.

Regioselectivity Rules (S_NAr)

In Nucleophilic Aromatic Substitution (S_NAr), the reactivity order is:

- C4-Br (Most Reactive): The C4 position is para-like to N1 and ortho-like to N3, making it highly electron-deficient. The adjacent C5-Cl (electron-withdrawing) further activates C4.
- C2-Br (Intermediate): Less reactive than C4 due to steric hindrance and electronic distribution, but can be displaced under harsher conditions or after C4 substitution.
- C5-Cl (Least Reactive): The C5-Cl bond is extremely stable against S_NAr. It is typically retained to modulate metabolic stability or serves as a handle for Palladium-catalyzed cross-coupling (Suzuki/Stille) after the bromines have been substituted.

Experimental Workflow: Sequential Functionalization

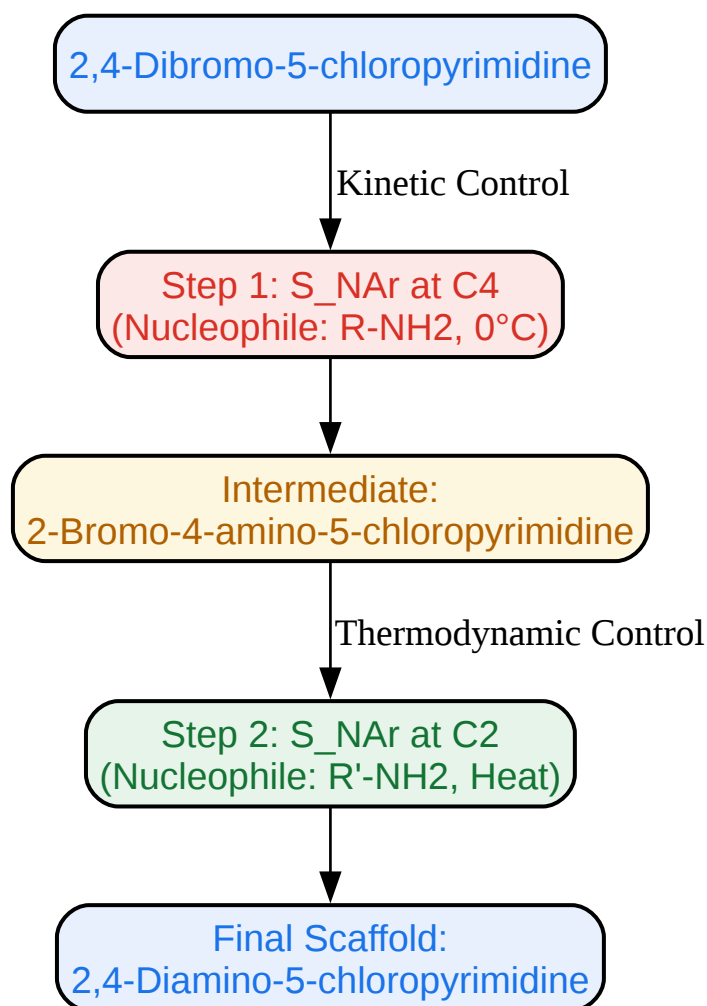

[Click to download full resolution via product page](#)

Figure 2: Sequential displacement strategy for generating unsymmetrical pyrimidine libraries.

Applications in Drug Discovery

Kinase Inhibitor Scaffolds

This intermediate is a bioisostere for the purine ring of ATP.

- C4-Position: Typically substituted with an aniline or heterocycle that binds to the "hinge region" of the kinase ATP-binding pocket.
- C5-Chlorine: The chlorine atom is lipophilic and electron-withdrawing. It often fills a small hydrophobic pocket (gatekeeper residue) in the enzyme active site, improving potency and selectivity compared to the hydrogen-substituted analog.

- C2-Position: Used to attach solubilizing groups (e.g., piperazines, morpholines) that extend towards the solvent front, improving pharmacokinetic properties (ADME).

Case Study Logic: Library Generation

To synthesize a library of 50 potential EGFR inhibitors:

- Batch 1: React **2,4-dibromo-5-chloropyrimidine** with 10 different anilines at C4 (0°C, THF).
- Batch 2: Isolate the 10 intermediates.
- Batch 3: React each intermediate with 5 different solubilizing amines at C2 (80°C, Dioxane).
- Result: 50 unique compounds with a fixed 5-Cl core.

Safety & Handling (SDS Summary)

Hazard Class	Statement	Precaution
Skin Corr. 1B	Causes severe skin burns	Wear nitrile gloves (double gloving recommended) and lab coat.
Eye Dam. 1	Causes serious eye damage	Wear chemical safety goggles. Use a face shield if handling >1g.
Acute Tox.	Harmful if swallowed/inhaled	Handle only in a functioning fume hood.
Reactivity	Reacts violently with water	Keep dry. Quench reactions cautiously.

First Aid:

- Eye Contact: Rinse immediately with water for 15 minutes.[5] Consult an ophthalmologist.
- Skin Contact: Wash off immediately with soap and plenty of water. Remove contaminated clothing.[6]

References

- National Center for Biotechnology Information (2025). PubChem Compound Summary for CID 130114675, **2,4-Dibromo-5-chloropyrimidine**. Retrieved from [[Link](#)]

Need Custom Synthesis?

BenchChem offers custom synthesis for rare earth carbides and specific isotopic labeling.

Email: info@benchchem.com or [Request Quote Online](#).

Sources

- 1. [scribd.com](https://www.scribd.com) [[scribd.com](https://www.scribd.com)]
- 2. pdf.benchchem.com [pdf.benchchem.com]
- 3. pdf.benchchem.com [pdf.benchchem.com]
- 4. pdf.benchchem.com [pdf.benchchem.com]
- 5. [angenechemical.com](https://www.angenechemical.com) [[angenechemical.com](https://www.angenechemical.com)]
- 6. [afgsci.com](https://www.afgsci.com) [[afgsci.com](https://www.afgsci.com)]
- To cite this document: BenchChem. [2,4-Dibromo-5-chloropyrimidine: Technical Guide & Synthetic Utility]. BenchChem, [2026]. [Online PDF]. Available at: [<https://www.benchchem.com/product/b8089866/docs#2-4-dibromo-5-chloropyrimidine-technical-guide-synthetic-utility>]

Disclaimer & Data Validity:

The information provided in this document is for Research Use Only (RUO) and is strictly not intended for diagnostic or therapeutic procedures. While BenchChem strives to provide accurate protocols, we make no warranties, express or implied, regarding the fitness of this product for every specific experimental setup.

Technical Support: The protocols provided are for reference purposes. Unsure if this reagent suits your experiment?

Need Industrial/Bulk Grade? [Request Custom Synthesis Quote](#)

BenchChem

Our mission is to be the trusted global source of essential and advanced chemicals, empowering scientists and researchers to drive progress in science and industry.

Contact

Address: 3281 E Guasti Rd

Ontario, CA 91761, United States

Phone: (601) 213-4426

Email: info@benchchem.com

[Contact our Ph.D. Support Team for a compatibility check](#)