

Liquid Crystal Behavior of Cholesteryl Palmitoleate Esters

Author: BenchChem Technical Support Team. **Date:** April 2026

Compound of Interest

Compound Name: *Cholesteryl palmitoleate*

CAS No.: 1797-71-3

Cat. No.: B8088718

[Get Quote](#)

Technical Guide & Characterization Protocol

Executive Summary

Cholesteryl palmitoleate (CP), the ester of cholesterol and *cis*-9-hexadecenoic acid (C16:1), represents a critical class of unsaturated cholesteryl esters (CEs). Unlike its saturated counterparts (e.g., cholesteryl palmitate), CP exhibits a distinct mesomorphic profile characterized by a monotropic smectic phase and an enantiotropic cholesteric phase. Its unsaturation at the

position introduces a "kink" in the acyl chain, significantly lowering phase transition temperatures and increasing membrane fluidity. This property is increasingly leveraged in Lipid Nanoparticle (LNP) engineering to modulate payload release kinetics and enhance endosomal escape.

Chemical & Structural Identity

- IUPAC Name: 3

-cholest-5-en-3-yl (9Z)-hexadec-9-enoate

- Molecular Formula:
- Molecular Weight: 623.0 g/mol
- Crystal System: Monoclinic, Space Group

[1]

- Structural Feature: The cis-double bond at C9 of the fatty acid chain disrupts the dense packing observed in saturated CEs, leading to a Monolayer Type I crystal packing arrangement.

Mesomorphic Behavior & Phase Transitions

Cholesteryl palmitoleate behaves as a thermotropic liquid crystal. Its phase transitions are sensitive to thermal history, exhibiting both stable (enantiotropic) and metastable (monotropic) phases.

Phase Transition Data

The following data consolidates differential scanning calorimetry (DSC) and polarizing optical microscopy (POM) observations.

Transition Type	Phase Change	Temperature (K)	Temperature (°C)	Enthalpy (, kJ/mol)	Nature
Melting	Crystal Isotropic Liquid	350.4 K	77.25 °C	56.2	Enantiotropic
Mesophase (Cooling)	Isotropic Cholesteric	355.0 K	81.85 °C	1.3	Enantiotropic *
Mesophase (Cooling)	Cholesteric Smectic A	349.9 K	76.75 °C	0.4	Monotropic
Crystallization	Smectic Crystal	< 300 K	< 27 °C	-	Supercooling dependent

Technical Note on Enantiotropy: Strictly speaking, if

, the smectic phase is monotropic (observable only upon supercooling the isotropic melt). The cholesteric phase exists in a narrow range just above the melting point or upon cooling. The "Isotropic

Cholesteric" transition at 81.85°C suggests a stable cholesteric window above the melting point (77.25°C), making the Cholesteric phase enantiotropic and the Smectic phase monotropic.

Visualizing the Phase Logic

The following diagram illustrates the thermodynamic pathways accessible during heating and cooling cycles.

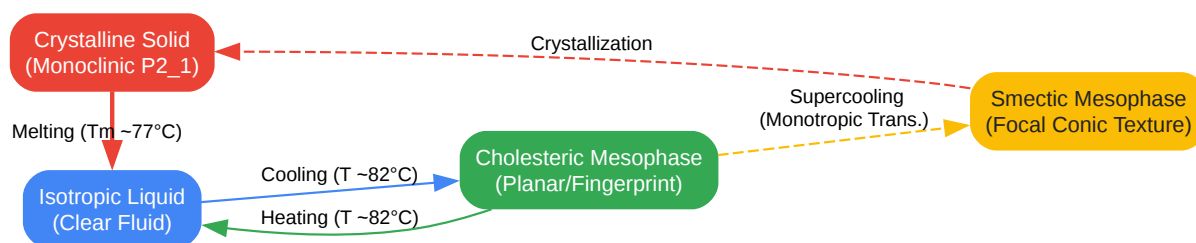

[Click to download full resolution via product page](#)

Figure 1: Thermotropic phase transition pathways of **Cholesteryl Palmitoleate**. Note the monotropic nature of the Smectic phase, accessible primarily through supercooling.

Optical Textures (POM)

When viewed under a Polarizing Optical Microscope (crossed polarizers):

- Cholesteric Phase: Exhibits a "Planar" texture (Grandjean) appearing as a uniform color that shifts with temperature, or "Fingerprint" textures if the helical axis is parallel to the glass slides.
- Smectic Phase: Upon further cooling, the texture transforms into "Focal Conic" fans or "Batonnets," indicative of the layered Smectic A arrangement.

Biopharmaceutical Applications

The primary utility of CP lies in its ability to modulate the packing density of lipid bilayers and cores.

Lipid Nanoparticles (LNPs)

In LNP formulations (e.g., for mRNA delivery), the lipid core's fluidity dictates the payload release rate.

- Mechanism: Saturated esters (e.g., Cholesteryl Stearate) crystallize into rigid cores, potentially trapping the payload. CP, with its cis-unsaturation, retains a liquid crystalline disorder at body temperature ().
- Benefit: This disorder facilitates fusion with the endosomal membrane, enhancing cytosolic release of mRNA.

Atherosclerosis Modeling

CP is a major component of the "lipid droplets" found in foam cells.

- Pathology: The transition from liquid crystalline to solid crystalline CP within macrophages can trigger inflammation. Researchers use CP to model the physical state of plaques; maintaining CP in a liquid crystal state (via temperature or hydration) is often correlated with metabolically active, rather than necrotic, plaques.

Experimental Protocols

Synthesis of Cholesteryl Palmitoleate

Objective: Synthesize high-purity CP avoiding oxidation of the alkene group.

Reagents:

- Cholesterol (Recrystallized from ethanol)
- Palmitoleoyl Chloride (cis-9-hexadecenoyl chloride)
- Triethylamine (TEA) (Acid scavenger)
- Dichloromethane (DCM) (Anhydrous)
- Inert Gas (N₂ or Ar)

Workflow Diagram:

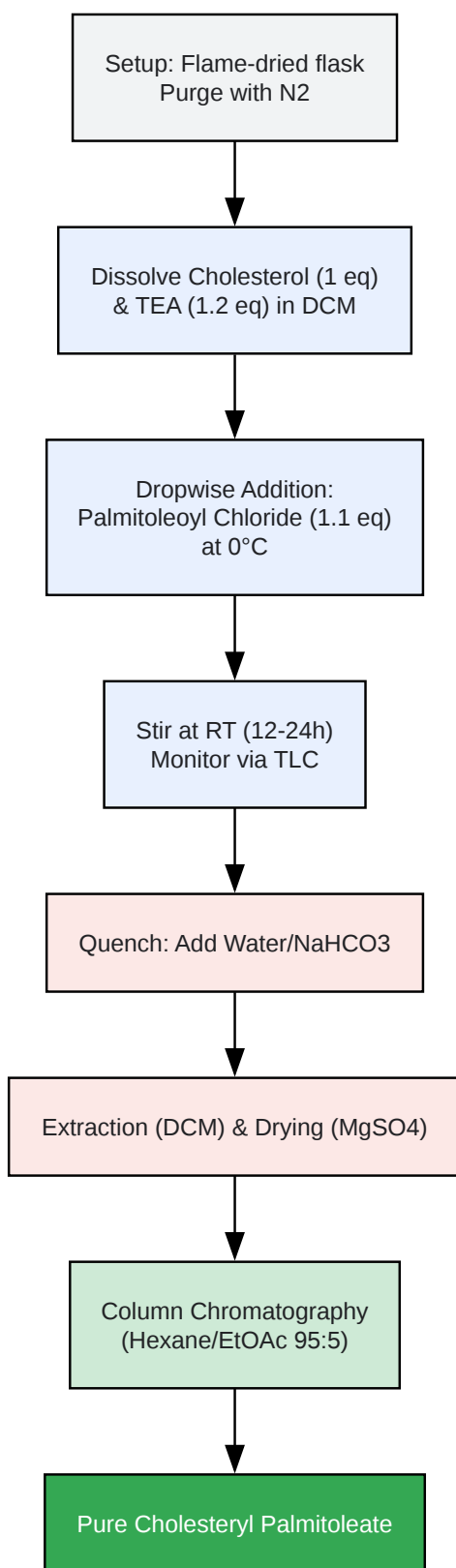

[Click to download full resolution via product page](#)

Figure 2: Acid chloride esterification workflow under inert conditions to prevent lipid oxidation.

Characterization via DSC

Objective: Determine precise

and mesophase transitions.

- Sample Prep: Weigh 2-5 mg of CP into an aluminum pan; crimp seal.
- Reference: Empty crimped aluminum pan.
- Protocol:
 - Equilibrate: Hold at 20°C for 5 min.
 - Heat: Ramp 10°C/min to 100°C (Observe Melting).
 - Cool: Ramp 5°C/min to 20°C (Observe Mesophase formation).
 - Re-Heat: Ramp 10°C/min to 100°C.
- Analysis: The cooling curve is critical for identifying the monotropic Smectic transition, which will appear as a small exotherm below the Cholesteric exotherm.

References

- Kishimoto, H., Iwasaki, M., et al. (1986).[2] Thermodynamic properties of cholesteryl esters. [3][4][5]Journal of the Chemical Society, Faraday Transactions.
- Barrall, E. M., Porter, R. S., & Johnson, J. F. (1967). Heats of Transition for Some Cholesteryl Esters by Differential Scanning Calorimetry.[3][4][6]Journal of Physical Chemistry.
- Small, D. M. (1984). Lateral Chain Packing in Cholesteryl Esters.Journal of Lipid Research. [Link](#)
- Ginsburg, G. S., et al. (1984). Conformational changes of **cholesteryl palmitoleate** in the crystal structure at low temperature.[1]Journal of Lipid Research. [Link](#)

- Lundberg, B. (1975). Thermal properties of systems containing cholesteryl esters.[3][4][5][6][7][8][9]Acta Chemica Scandinavica.

Need Custom Synthesis?

BenchChem offers custom synthesis for rare earth carbides and specific isotopic labeling.

Email: info@benchchem.com or [Request Quote Online](#).

Sources

- 1. Conformational changes of cholesteryl palmitoleate in the crystal structure at low temperature - PubMed [pubmed.ncbi.nlm.nih.gov]
- 2. Cholesteryl palmitate [webbook.nist.gov]
- 3. Physical properties of cholesteryl esters - PubMed [pubmed.ncbi.nlm.nih.gov]
- 4. pdf.benchchem.com [pdf.benchchem.com]
- 5. lib.osau.edu.ua [lib.osau.edu.ua]
- 6. mriquestions.com [mriquestions.com]
- 7. mint.uthm.edu.my [mint.uthm.edu.my]
- 8. researchgate.net [researchgate.net]
- 9. jetp.ras.ru [jetp.ras.ru]
- To cite this document: BenchChem. [Liquid Crystal Behavior of Cholesteryl Palmitoleate Esters]. BenchChem, [2026]. [Online PDF]. Available at: [<https://www.benchchem.com/product/b8088718/docs#liquid-crystal-behavior-of-cholesteryl-palmitoleate-esters>]

Disclaimer & Data Validity:

The information provided in this document is for Research Use Only (RUO) and is strictly not intended for diagnostic or therapeutic procedures. While BenchChem strives to provide accurate protocols, we make no warranties, express or implied, regarding the fitness of this product for every specific experimental setup.

Technical Support: The protocols provided are for reference purposes. Unsure if this reagent suits your experiment?

Need Industrial/Bulk Grade? [Request Custom Synthesis Quote](#)

BenchChem

Our mission is to be the trusted global source of essential and advanced chemicals, empowering scientists and researchers to drive progress in science and industry.

Contact

Address: 3281 E Guasti Rd
Ontario, CA 91761, United States
Phone: (601) 213-4426
Email: info@benchchem.com

[Contact our Ph.D. Support Team for a compatibility check](#)