

comparative studies of PROTACs using different amine linkers on lenalidomide

Author: BenchChem Technical Support Team. **Date:** April 2026

Compound of Interest

Compound Name: *Lenalidomide-C4-NH2 hydrochloride*
Cat. No.: *B8085341*

[Get Quote](#)

A Comparative Guide to Amine Linkers in Lenalidomide-Based PROTACs

For Researchers, Scientists, and Drug Development Professionals

Proteolysis-targeting chimeras (PROTACs) have revolutionized targeted protein degradation by harnessing the cell's ubiquitin-proteasome system. In the design of these heterobifunctional molecules, the linker connecting the target-binding warhead and the E3 ligase ligand is a critical determinant of efficacy. This guide provides a comparative analysis of different linker strategies for PROTACs that utilize lenalidomide to recruit the Cereblon (CRBN) E3 ligase, with a focus on the impact of amine-containing linkers.

The Crucial Role of the Linker in PROTAC Function

The linker is not merely a spacer but plays a pivotal role in the formation of a productive ternary complex between the target protein, the PROTAC, and the E3 ligase.^[1] Its length, composition, rigidity, and attachment point can significantly influence the efficacy, selectivity, and pharmacokinetic properties of the resulting PROTAC.^{[1][2]} Key characteristics of linkers that

are frequently optimized include their chemical nature (e.g., polyethylene glycol (PEG) or alkyl chains), length, and hydrophilicity.[1]

Comparative Analysis of Linker Performance

The choice of linker can dramatically impact the degradation efficiency, which is typically measured by the half-maximal degradation concentration (DC50) and the maximum level of degradation (Dmax).[1] While a universally optimal linker does not exist, general principles have emerged from various studies. The following table summarizes representative data from studies comparing different linkers in lenalidomide-based PROTACs targeting the same protein, offering a quantitative perspective on how linker modifications can affect degradation.

PROTAC	Target Protein	E3 Ligase Ligand	Linker Type	Degradation DC50	Max Degradation (Dmax)	Key Feature
dBET1	BRD4	Pomalidomide	PEG-based	~1.8 nM	>98%	Highly potent degrader of BET proteins.[3]
ARV-110	Androgen Receptor (AR)	Proprietary CRBN Ligand	Proprietary	~1 nM (in AR-sensitive cells)	>95%	First oral PROTAC to enter clinical trials.[3]
TBK1 Degradation (21 atom linker)	TBK1	Not Specified	Alkyl and ether units	3 nM	96%	Potency decreased with a 29-atom linker. [2][4]
TBK1 Degradation (29 atom linker)	TBK1	Not Specified	Alkyl and ether units	292 nM	76%	Demonstrates the importance of optimal linker length.[2][4]

Note: Data is compiled from multiple sources and assays; direct comparison should be made with caution.[3]

Linker Composition: PEG vs. Alkyl Chains

Polyethylene glycol (PEG) and alkyl chains are the most prevalent motifs in PROTAC linkers.[1]

- PEG Linkers: These are generally more hydrophilic and can enhance the aqueous solubility and cell permeability of the PROTAC molecule.[1][3] The ether oxygens in the PEG chain can also form hydrogen bonds, potentially influencing the conformation of the ternary complex.[1]
- Alkyl Linkers: These are more hydrophobic and rigid compared to PEG linkers of a similar length.[1] While simple alkyl chains are common, they can increase the lipophilicity of the molecule, which may reduce solubility.[3]

The Impact of Linker Length

The length of the linker is a critical parameter that requires optimization for each target protein and ligand pair.[1] A linker that is too short may cause steric clashes and hinder the formation of a stable ternary complex, whereas an excessively long linker can lead to reduced potency due to entropic penalties.[1] For instance, in a series of PROTACs targeting TBK1, linkers between 12 and 29 atoms all showed submicromolar degradation potency, with a 21-atom linker being the most potent.[2][4]

Signaling Pathways and Experimental Workflows

To facilitate a deeper understanding of the underlying mechanisms and experimental procedures, the following diagrams illustrate the PROTAC-mediated protein degradation pathway and a typical workflow for evaluating PROTAC efficacy.

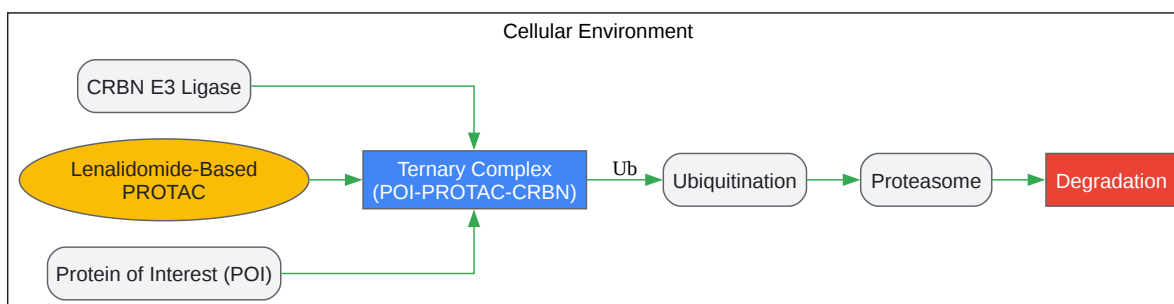

[Click to download full resolution via product page](#)

Caption: Mechanism of Action for a Lenalidomide-Based PROTAC.

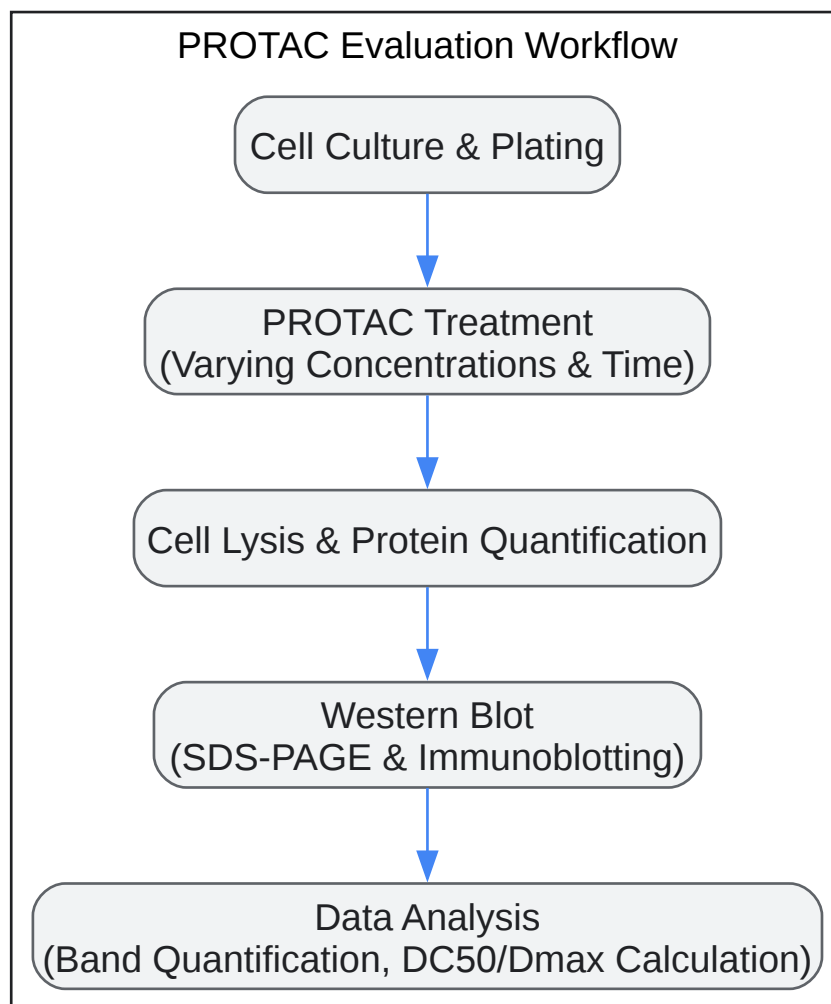

[Click to download full resolution via product page](#)

Need Custom Synthesis?

BenchChem offers custom synthesis for rare earth carbides and specific isotopic labeling.

Email: info@benchchem.com or [Request Quote Online](#).

References

- [1. benchchem.com \[benchchem.com\]](#)
- [2. Current strategies for the design of PROTAC linkers: a critical review - PMC \[pmc.ncbi.nlm.nih.gov\]](#)
- [3. benchchem.com \[benchchem.com\]](#)
- [4. explorationpub.com \[explorationpub.com\]](#)
- To cite this document: BenchChem. [comparative studies of PROTACs using different amine linkers on lenalidomide]. BenchChem, [2026]. [Online PDF]. Available at: [<https://www.benchchem.com/product/b8085341/docs#comparative-studies-of-protacs-using-different-amine-linkers-on-lenalidomide>]

Disclaimer & Data Validity:

The information provided in this document is for Research Use Only (RUO) and is strictly not intended for diagnostic or therapeutic procedures. While BenchChem strives to provide accurate protocols, we make no warranties, express or implied, regarding the fitness of this product for every specific experimental setup.

Technical Support: The protocols provided are for reference purposes. Unsure if this reagent suits your experiment?

Need Industrial/Bulk Grade? [Request Custom Synthesis Quote](#)

BenchChem

Our mission is to be the trusted global source of essential and advanced chemicals, empowering scientists and researchers to drive progress in science and industry.

Contact

Address: 3281 E Guasti Rd

Ontario, CA 91761, United States

Phone: (601) 213-4426

Email: info@benchchem.com

Contact our Ph.D. Support Team for a compatibility check