

Preparing CX-6258 Hydrochloride Hydrate Stock Solutions: Application Notes and Protocols

Author: BenchChem Technical Support Team. **Date:** April 2026

Compound of Interest

Compound Name: CX-6258 hydrochloride hydrate

Cat. No.: B8082075

[Get Quote](#)

For Researchers, Scientists, and Drug Development Professionals

Abstract

This document provides detailed protocols for the preparation, storage, and handling of stock solutions of **CX-6258 hydrochloride hydrate**, a potent and selective pan-Pim kinase inhibitor. Adherence to these guidelines is crucial for ensuring the stability, activity, and reproducibility of experimental results. This guide also includes a summary of the compound's key properties and a diagram of the Pim kinase signaling pathway it inhibits.

Introduction to CX-6258 Hydrochloride Hydrate

CX-6258 is a small molecule inhibitor targeting the Pim family of serine/threonine kinases (Pim-1, Pim-2, and Pim-3) with high potency.^{[1][2][3][4]} These kinases are key regulators of cell survival, proliferation, and apoptosis, and their overexpression is implicated in various cancers.^[5] CX-6258 inhibits these kinases in an ATP-competitive manner, leading to the suppression of tumor growth.^[6] Its hydrochloride hydrate form is a common salt used for research and development.

Physicochemical and Biological Properties

A comprehensive summary of the quantitative data for **CX-6258 hydrochloride hydrate** is presented in the table below for easy reference and comparison.

Property	Value
Molecular Formula	C ₂₆ H ₂₄ ClN ₃ O ₃ · HCl · H ₂ O
Molecular Weight	516.42 g/mol [2][3]
CAS Number	1353858-99-7[2][3]
Appearance	Yellow to orange solid[2]
IC ₅₀ Values	Pim-1: 5 nM, Pim-2: 25 nM, Pim-3: 16 nM[1][2] [7][8]
Solubility (In Vitro)	DMSO: ≥ 50 mg/mL (100.32 mM); it is advised to use fresh DMSO as moisture can reduce solubility.[7] Water: 7.14 mg/mL (13.83 mM); requires sonication and heating to 60°C.[2] Ethanol: 1-2 mg/mL[7]
Storage (Powder)	3 years at -20°C, 2 years at 4°C[7][8]
Storage (Stock Solution)	1 year at -80°C in solvent, 1 month at -20°C in solvent. It is recommended to aliquot to avoid repeated freeze-thaw cycles.[1][7]

Experimental Protocols

Preparation of a 10 mM DMSO Stock Solution

This protocol describes the preparation of a 10 mM stock solution of **CX-6258 hydrochloride hydrate** in Dimethyl Sulfoxide (DMSO).

Materials:

- **CX-6258 hydrochloride hydrate** powder

- Anhydrous/fresh Dimethyl Sulfoxide (DMSO)
- Sterile microcentrifuge tubes or vials
- Calibrated micropipettes
- Vortex mixer
- Sonicator (optional)

Procedure:

- Aseptic Technique: Perform all steps in a sterile environment (e.g., a laminar flow hood) to prevent contamination.
- Calculate Required Mass: Use the following formula to determine the mass of **CX-6258 hydrochloride hydrate** needed: $\text{Mass (mg)} = \text{Desired Volume (mL)} \times 10 \text{ mM} \times 516.42 \text{ (g/mol)} / 1000$ For 1 mL of a 10 mM stock, 5.16 mg of CX-6258 is required.
- Weighing: Carefully weigh the calculated amount of **CX-6258 hydrochloride hydrate** powder.
- Dissolution: Add the appropriate volume of fresh, anhydrous DMSO to the powder. Using DMSO that has absorbed moisture can significantly decrease solubility.[7]
- Mixing: Vortex the solution thoroughly until the powder is completely dissolved. If necessary, brief sonication in a water bath can aid dissolution.
- Aliquoting: Dispense the stock solution into smaller, single-use aliquots in sterile microcentrifuge tubes. This minimizes the number of freeze-thaw cycles the main stock undergoes.
- Storage: Store the aliquots at -80°C for long-term storage (up to 1 year) or at -20°C for short-term storage (up to 1 month).[1][7]

Preparation of Working Solutions for Cell-Based Assays

For most in vitro cell culture experiments, the DMSO stock solution will need to be further diluted in cell culture medium to the final desired concentration.

Procedure:

- Thawing: Thaw a single aliquot of the 10 mM CX-6258 stock solution at room temperature.
- Serial Dilution: Perform serial dilutions of the stock solution in sterile cell culture medium to achieve the desired final concentration.
 - Important: The final concentration of DMSO in the cell culture medium should be kept low (typically $\leq 0.1\%$) to avoid solvent-induced cytotoxicity.
- Application: Add the final working solution to your cell cultures and proceed with the experiment.

Visualization of Signaling Pathway and Workflow

The following diagrams illustrate the Pim kinase signaling pathway targeted by CX-6258 and the general experimental workflow for preparing and using the stock solution.

Pim Kinase Signaling Pathway and Inhibition by CX-6258

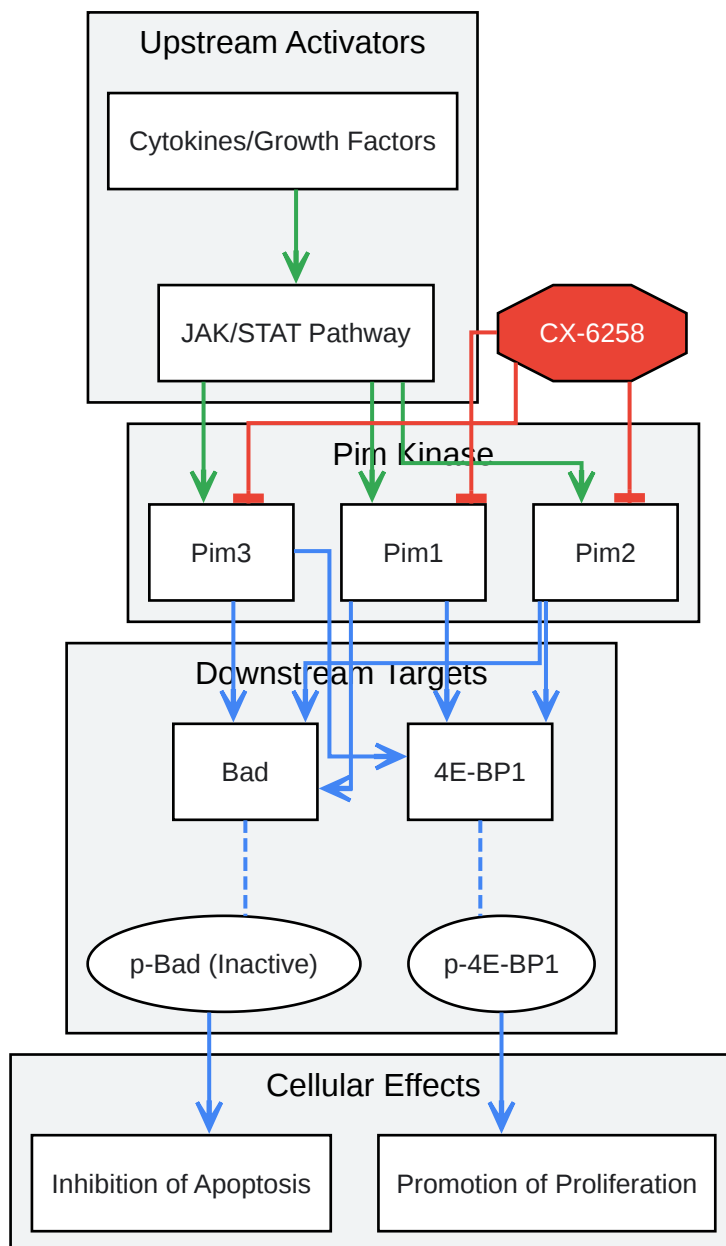

[Click to download full resolution via product page](#)

Caption: CX-6258 inhibits Pim kinases, preventing phosphorylation of Bad and 4E-BP1.

CX-6258 Stock Solution Preparation Workflow

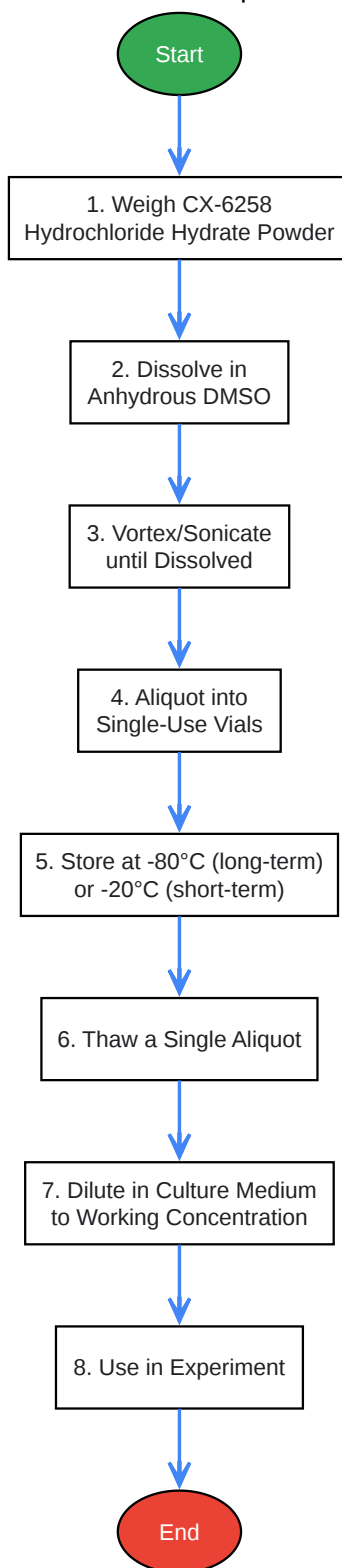

[Click to download full resolution via product page](#)

Caption: Workflow for preparing and using **CX-6258 hydrochloride hydrate** stock solutions.

Need Custom Synthesis?

BenchChem offers custom synthesis for rare earth carbides and specific isotopic labeling.

Email: info@benchchem.com or [Request Quote Online](#).

References

- [1. medchemexpress.com \[medchemexpress.com\]](https://www.medchemexpress.com)
- [2. medchemexpress.com \[medchemexpress.com\]](https://www.medchemexpress.com)
- [3. CX-6258 hydrochloride hydrate | Pim inhibitor | Probechem Biochemicals \[probechem.com\]](https://www.probechem.com)
- [4. CX-6258 hydrochloride hydrate | TargetMol \[targetmol.com\]](https://www.targetmol.com)
- [5. Discovery of CX-6258. A Potent, Selective, and Orally Efficacious pan-Pim Kinases Inhibitor - PMC \[pmc.ncbi.nlm.nih.gov\]](https://pubmed.ncbi.nlm.nih.gov)
- [6. merckmillipore.com \[merckmillipore.com\]](https://www.merckmillipore.com)
- [7. selleckchem.com \[selleckchem.com\]](https://www.selleckchem.com)
- [8. file.medchemexpress.com \[file.medchemexpress.com\]](https://www.file.medchemexpress.com)
- To cite this document: BenchChem. [Preparing CX-6258 Hydrochloride Hydrate Stock Solutions: Application Notes and Protocols]. BenchChem, [2026]. [Online PDF]. Available at: [\[https://www.benchchem.com/product/b8082075/docs#preparing-cx-6258-hydrochloride-hydrate-stock-solutions-application-notes-and-protocols\]](https://www.benchchem.com/product/b8082075/docs#preparing-cx-6258-hydrochloride-hydrate-stock-solutions-application-notes-and-protocols)

Disclaimer & Data Validity:

The information provided in this document is for Research Use Only (RUO) and is strictly not intended for diagnostic or therapeutic procedures. While BenchChem strives to provide accurate protocols, we make no warranties, express or implied, regarding the fitness of this product for every specific experimental setup.

Technical Support: The protocols provided are for reference purposes. Unsure if this reagent suits your experiment?

Need Industrial/Bulk Grade? [Request Custom Synthesis Quote](#)

BenchChem

Our mission is to be the trusted global source of essential and advanced chemicals, empowering scientists and researchers to drive progress in science and industry.

Contact

Address: 3281 E Guasti Rd
Ontario, CA 91761, United States
Phone: (601) 213-4426
Email: info@benchchem.com

[Contact our Ph.D. Support Team for a compatibility check](#)