

# A Comparative Analysis of A-770041's Impact on Downstream Signaling Pathways

**Author:** BenchChem Technical Support Team. **Date:** April 2026

## Compound of Interest

Compound Name:	A-770041
CAS No.:	1140478-96-1
Cat. No.:	B8082437

[Get Quote](#)

An objective guide for researchers on the performance and specificity of **A-770041** in comparison to other kinase inhibitors.

**A-770041** is a potent and selective, orally bioavailable small-molecule inhibitor of Lymphocyte-specific protein tyrosine kinase (Lck), a member of the Src family of tyrosine kinases.<sup>[1][2][3]</sup> Lck plays a critical role in the initiation of T-cell receptor (TCR) signaling, which is essential for T-cell development, activation, and proliferation.<sup>[1][4]</sup> Consequently, inhibition of Lck is a key therapeutic strategy for managing T-cell-mediated autoimmune diseases and organ transplant rejection.<sup>[1][5]</sup> This guide provides a detailed comparison of **A-770041**'s effects on downstream signaling pathways versus other relevant inhibitors, supported by experimental data and protocols.

## Mechanism of Action: A-770041's Role in the Lck Signaling Pathway

Upon engagement of the T-cell receptor (TCR), Lck is activated and phosphorylates the immunoreceptor tyrosine-based activation motifs (ITAMs) within the CD3 complex. This action initiates a cascade of downstream signaling events, including the recruitment and activation of

ZAP-70, which in turn activates key pathways like the PLC $\gamma$ 1-Calcium influx, Ras-MAPK (Erk1/2), and PI3K/Akt pathways.[4] These pathways converge to activate transcription factors, notably NF- $\kappa$ B, leading to the production of crucial cytokines such as Interleukin-2 (IL-2) and Transforming growth factor-beta (TGF- $\beta$ ), which drive T-cell proliferation and differentiation.[1][4][6][7]

**A-770041** selectively binds to the ATP-binding site of Lck, inhibiting its kinase activity and thereby blocking the entire downstream signaling cascade.

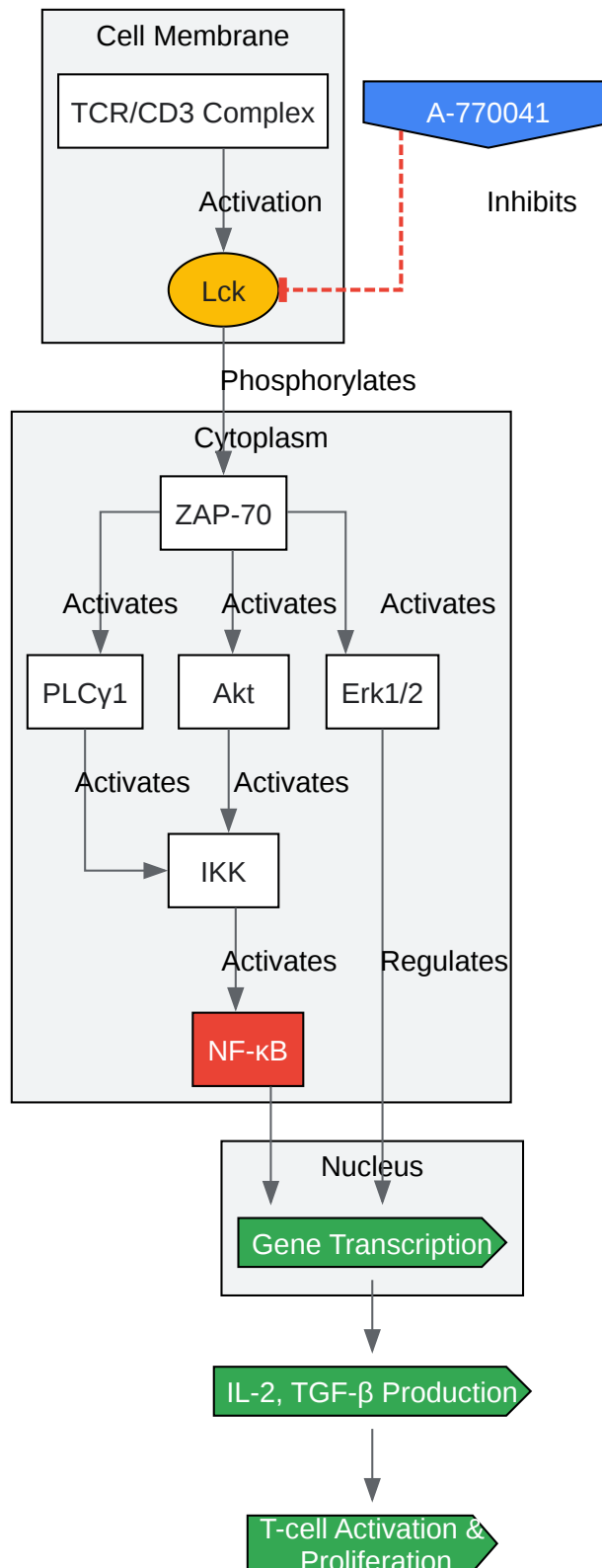

[Click to download full resolution via product page](#)

**Caption:** Lck signaling pathway and the inhibitory action of **A-770041**.

## Quantitative Inhibitor Profile

**A-770041** demonstrates high selectivity for Lck over other Src family kinases, a critical feature for minimizing off-target effects.

Inhibitor	Target(s)	IC50 / EC50	Selectivity	Reference
A-770041	Lck	147 nM (IC50)	300-fold vs. Fyn; 60-fold vs. Src	[1][2]
Fyn	44.1 μM (IC50)	-	[2]	
Src	9.1 μM (IC50)	-	[2]	
IL-2 Production (in vitro)	~80 nM (EC50)	-	[1]	
IL-2 Production (in vivo)	78 nM (EC50)	-	[1]	
Nintedanib	Lck	22 nM (IC50)	Also targets VEGFR, PDGFR, FGFR	[6][7]
VEGFR, PDGFR, FGFR	Potent inhibitor	Broad spectrum	[6][7]	
Cyclosporin A	Calcineurin	-	Different mechanism	[1]

## Comparative Analysis: A-770041 vs. Other Inhibitors

### A-770041 vs. Nintedanib: Specific vs. Multi-Targeted Kinase Inhibition

Nintedanib is a multi-targeted tyrosine kinase inhibitor approved for treating idiopathic pulmonary fibrosis (IPF) that, in addition to targeting receptor tyrosine kinases like PDGFR and VEGFR, also potently inhibits Lck.[6][7] A direct comparison reveals differences in their effects on Lck phosphorylation in T-cells.

## Experimental Data: Inhibition of Lck Phosphorylation

Inhibitor	Concentration for Effect	Cell Type	Result	Reference
A-770041	≥100 nM	Murine CD4+ T-cells	Effective inhibition of Lck phosphorylation	[6][7]
Nintedanib	≥30 nM	Murine CD4+ T-cells	Effective inhibition of Lck phosphorylation	[6][7]

While Nintedanib shows a lower effective concentration for Lck phosphorylation in this specific assay, **A-770041**'s high selectivity for Lck ensures that the observed downstream effects are primarily due to the inhibition of this specific kinase, avoiding the confounding effects of inhibiting other pathways like PDGFR or VEGFR.[6][7] This makes **A-770041** a more precise tool for studying Lck-specific functions. For instance, studies using **A-770041** have specifically demonstrated that Lck inhibition attenuates lung fibrosis by suppressing TGF- $\beta$  production in regulatory T-cells.[6][7]

## Experimental Protocol: Lck Phosphorylation Assay

This protocol outlines the method used to compare the inhibitory effects of **A-770041** and Nintedanib on Lck phosphorylation.[6][7]

- Cell Isolation: CD4+ T-cells are isolated from murine spleens using Magnetic Activated Cell Sorting (MACS).
- Cell Stimulation: Isolated T-cells are stimulated with anti-CD3/CD28 antibodies to activate the TCR signaling pathway.
- Inhibitor Incubation: Stimulated cells are incubated with varying concentrations of Nintedanib (0–300 nM) or **A-770041** (0–1000 nM) for 5 minutes.
- Analysis: The phosphorylation status of Lck is analyzed using an automated capillary-based immunoassay system (Simple Wes™).

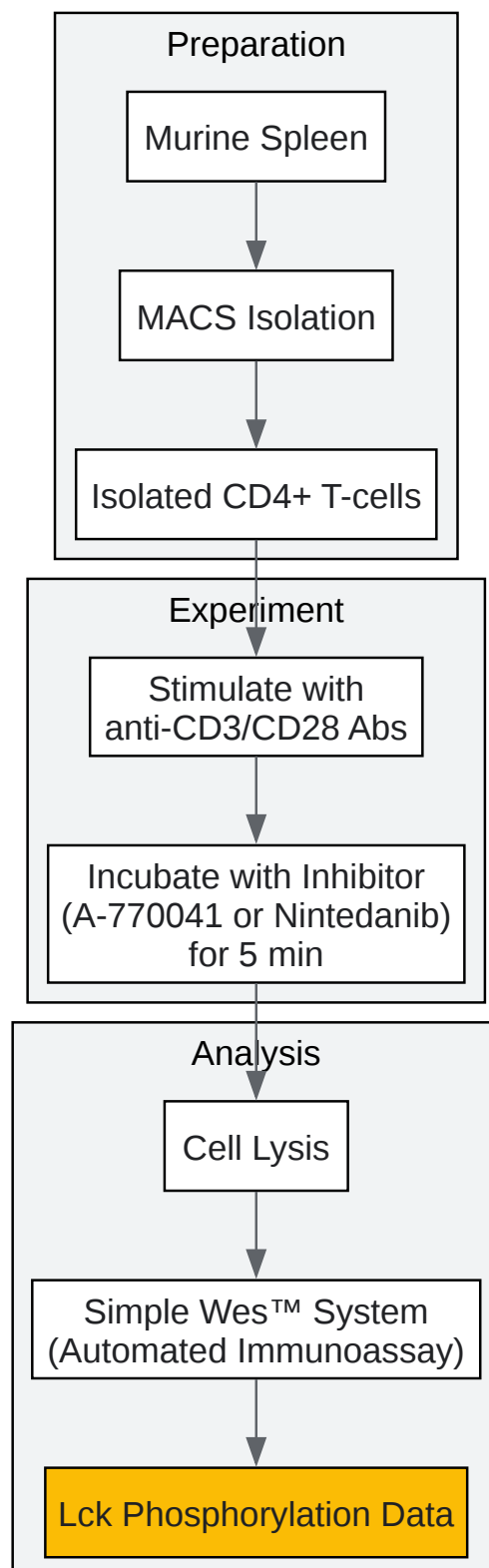

[Click to download full resolution via product page](#)

**Caption:** Experimental workflow for the Lck phosphorylation assay.

## A-770041 vs. Cyclosporin A: Targeted Kinase Inhibition vs. Broad Immunosuppression

Cyclosporin A is a widely used immunosuppressant that acts by inhibiting calcineurin, a different downstream component of the T-cell activation pathway. A comparison in a preclinical model of organ rejection highlights the efficacy and potentially different side-effect profiles of these two approaches.

### Experimental Data: Rat Heart Allograft Rejection Model

In a study involving the transplantation of hearts across a major histocompatibility barrier in rats, both **A-770041** and Cyclosporin A were effective at preventing organ rejection.[\[1\]](#)

Inhibitor	Dosage	Outcome	Key Observation	Reference
A-770041	20 mg/kg/day	Prevented rejection for >65 days	Minimal microvascular changes; less myocyte mineralization	<a href="#">[1]</a>
Cyclosporin A	10 mg/day	Prevented rejection for >65 days	Minimal microvascular changes; observed myocyte mineralization	<a href="#">[1]</a>

The key differentiator was that grafts from animals treated with **A-770041** showed less mineralization in myocytes compared to those treated with Cyclosporin A.[\[1\]](#) This suggests that the targeted inhibition of Lck by **A-770041** may offer a more favorable safety profile compared to the broader immunosuppressive mechanism of calcineurin inhibitors.

### Experimental Protocol: Heterotopic Heart Transplant Model

This protocol describes the in vivo model used to assess the efficacy of **A-770041** in preventing organ rejection.[1]

- Model: Heterotopic heart transplantation is performed in rats, with hearts from Brown Norway donors transplanted into Lewis recipients (a major histocompatibility barrier).
- Treatment Groups:
  - Vehicle control group.
  - **A-770041** group (e.g., 20 mg/kg/day).
  - Cyclosporin A group (10 mg/day).
- Monitoring: Graft survival is monitored daily.
- Histology: At the end of the study, grafts are harvested for histological analysis to assess microvascular changes, mononuclear infiltrates, and myocyte mineralization.

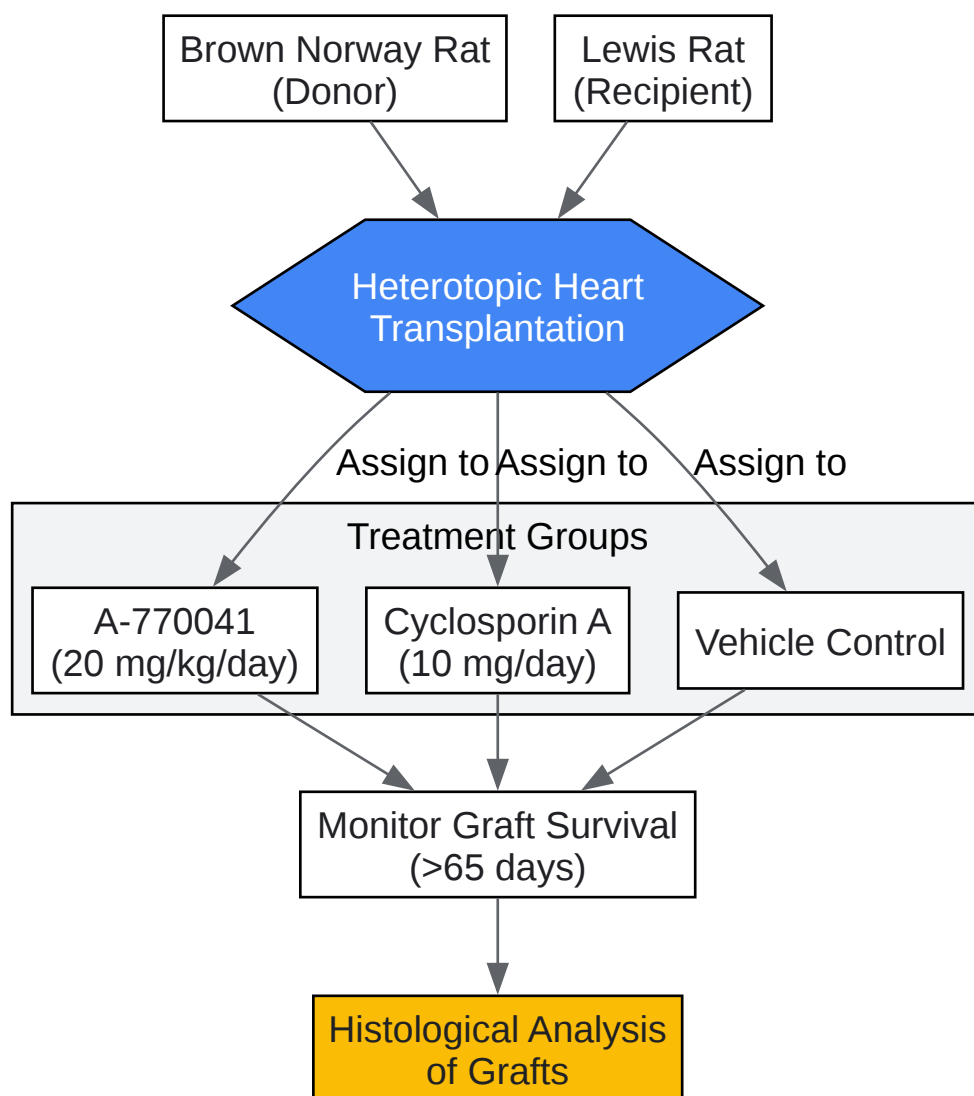

[Click to download full resolution via product page](#)

**Caption:** Workflow for the in vivo heart allograft rejection model.

## Conclusion

**A-770041** is a highly selective Lck inhibitor that effectively blocks T-cell activation and proliferation by targeting the apex of the TCR signaling cascade. Comparative data demonstrates its utility as a precise molecular probe for dissecting Lck-dependent pathways. When compared with multi-kinase inhibitors like Nintedanib, **A-770041** offers superior specificity, ensuring that observed effects are attributable to Lck inhibition. In preclinical models of organ transplantation, it shows efficacy comparable to standard immunosuppressants like Cyclosporin A but with a potentially improved side-effect profile, highlighting the therapeutic potential of targeted Lck inhibition.

### Need Custom Synthesis?

BenchChem offers custom synthesis for rare earth carbides and specific isotopic labeling.

Email: [info@benchchem.com](mailto:info@benchchem.com) or [Request Quote Online](#).

## References

- [1. A-770041, a novel and selective small-molecule inhibitor of Lck, prevents heart allograft rejection - PubMed \[pubmed.ncbi.nlm.nih.gov\]](#)
- [2. medchemexpress.com \[medchemexpress.com\]](#)
- [3. Discovery of A-770041, a src-family selective orally active Lck inhibitor that prevents organ allograft rejection - PubMed \[pubmed.ncbi.nlm.nih.gov\]](#)
- [4. New insights into the Lck-NF-κB signaling pathway - PMC \[pmc.ncbi.nlm.nih.gov\]](#)
- [5. researchgate.net \[researchgate.net\]](#)
- [6. The lymphocyte-specific protein tyrosine kinase-specific inhibitor A-770041 attenuates lung fibrosis via the suppression of TGF-β production in regulatory T-cells - PMC \[pmc.ncbi.nlm.nih.gov\]](#)
- [7. The lymphocyte-specific protein tyrosine kinase-specific inhibitor A-770041 attenuates lung fibrosis via the suppression of TGF-β production in regulatory T-cells | PLOS One \[journals.plos.org\]](#)
- To cite this document: BenchChem. [A Comparative Analysis of A-770041's Impact on Downstream Signaling Pathways]. BenchChem, [2026]. [Online PDF]. Available at: [\[https://www.benchchem.com/product/b8082437/docs#a-comparative-analysis-of-a-770041-s-impact-on-downstream-signaling-pathways\]](https://www.benchchem.com/product/b8082437/docs#a-comparative-analysis-of-a-770041-s-impact-on-downstream-signaling-pathways)

---

### Disclaimer & Data Validity:

The information provided in this document is for Research Use Only (RUO) and is strictly not intended for diagnostic or therapeutic procedures. While BenchChem strives to provide accurate protocols, we make no warranties, express or implied, regarding the fitness of this product for every specific experimental setup.

**Technical Support:** The protocols provided are for reference purposes. Unsure if this reagent suits your experiment?

**Need Industrial/Bulk Grade?** [Request Custom Synthesis Quote](#)

## BenchChem

Our mission is to be the trusted global source of essential and advanced chemicals, empowering scientists and researchers to drive progress in science and industry.

### Contact

Address: 3281 E Guasti Rd  
Ontario, CA 91761, United States  
Phone: (601) 213-4426  
Email: [info@benchchem.com](mailto:info@benchchem.com)

[Contact our Ph.D. Support Team for a compatibility check](#)