

# Comparative Guide: Detector Selection for Calcitriol Impurity Analysis

**Author:** BenchChem Technical Support Team. **Date:** May 2026

## Compound of Interest

Compound Name: Calcitriol Impurities A

Cat. No.: B8071406

[Get Quote](#)

## The Analytical Challenge: Why Calcitriol is Different

Calcitriol (

-dihydroxyvitamin

) represents a unique challenge in pharmaceutical analysis. As a high-potency, low-dose therapeutic (often dosed in micrograms), the threshold for impurity detection is vanishingly low. Furthermore, the molecule is chemically labile, susceptible to isomerization (Pre-calcitriol, Trans-calcitriol) and oxidation, all while sharing a nearly identical lipophilic backbone with its impurities.

In my experience developing methods for Vitamin D analogs, the "one-size-fits-all" detector approach fails. The choice between UV-Vis/PDA and LC-MS/MS is not just about sensitivity—it is about the nature of the impurity and the matrix (API vs. formulated product vs. biological fluid).

This guide objectively compares these detection technologies, supported by experimental protocols and decision frameworks.

## Detector Landscape: Technical Deep Dive

### A. UV-Vis / Photodiode Array (PDA): The QC Workhorse

The conjugated triene system in Calcitriol provides a characteristic UV absorption, typically monitored at 265 nm (maximum) or 230 nm (USP method for specific impurities).

- Mechanism: Direct absorption of the cis-triene chromophore.
- Strengths: Robust, linear for main peak, excellent for quantifying known isomers (Pre-calcitriol) that have distinct shifts.
- Weaknesses: Insufficient sensitivity for low-dose formulations (e.g., 0.25 µg capsules) without extensive sample concentration. It cannot distinguish co-eluting impurities with similar spectra.

### B. LC-MS/MS (Triple Quadrupole): The Sensitivity Gold Standard

For trace impurities or cleaning validation, UV is blind. LC-MS/MS fills this gap but faces a hurdle: Calcitriol is neutral and lipophilic, leading to poor ionization efficiency in standard ESI (Electrospray Ionization).

- Mechanism: Ionization (APCI or ESI) followed by mass filtration.
- The "Secret" Weapon: Derivatization. To achieve pg/mL sensitivity, we use Cookson-type reagents like PTAD (4-phenyl-1,2,4-triazoline-3,5-dione).<sup>[1]</sup> This Diels-Alder reaction adds a polar moiety, enhancing ionization efficiency by 100-fold <sup>[1]</sup>.
- Strengths: Femtogram-level sensitivity, structural identification of unknowns.
- Weaknesses: High cost, matrix effects (ion suppression), requires derivatization for maximum performance.

## Comparative Performance Data

The following data summarizes a comparative study analyzing Calcitriol API spiked with key impurities: Pre-calcitriol (thermodynamic isomer) and Tachysterol (photo-isomer).

Feature	HPLC-UV (PDA)	LC-MS/MS (APCI, No Deriv.)	LC-MS/MS (ESI, PTAD Deriv.) <sup>[2]</sup>
Detection Principle	Chromophore Abs (265 nm)	Protonation	Protonation of Adduct
LOD (Signal/Noise = 3)	~10 ng/mL	~1 ng/mL	~5-10 pg/mL
Linearity ( )	> 0.999 (High Range)	> 0.99 (Mid Range)	> 0.995 (Trace Range)
Selectivity	Moderate (Separation dependent)	High (Mass dependent)	Very High (Mass + Transition)
Isomer Differentiation	Good (Spectral shifts)	Poor (Isobaric)	Good (Chromatographic + Frag.)
Key Application	Raw Material QC, Dissolution	Cleaning Validation	Bioanalysis, Trace Impurities

“

*Scientist's Note: While MS is more sensitive, UV is superior for distinguishing isomers like Pre-calcitriol solely based on spectral shape if they co-elute. Pre-calcitriol has a*

*shift to ~260 nm compared to Calcitriol's 265 nm. In MS, these are isobaric (same mass), so chromatographic separation is non-negotiable.*

## Visualizing the Impurity Pathways & Method Selection

Understanding the degradation logic is crucial for choosing the detector.

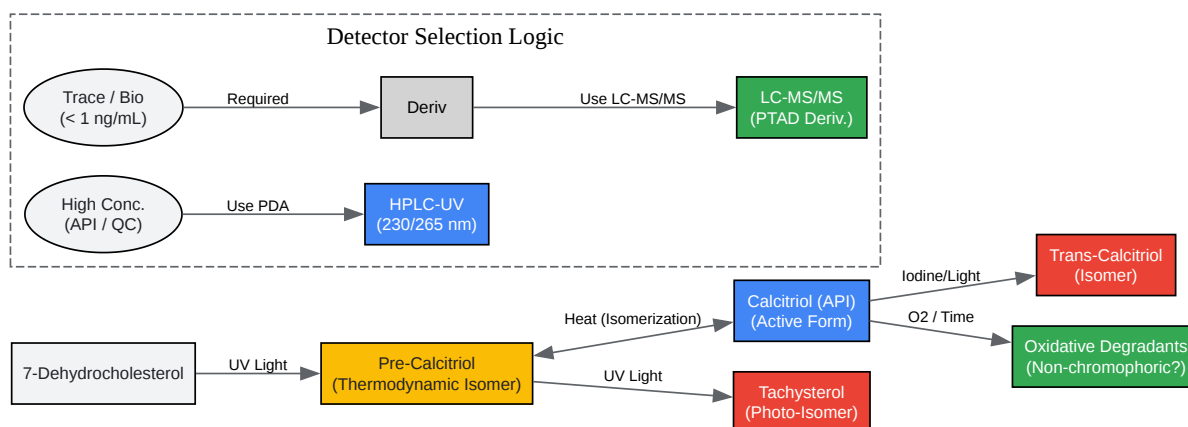

[Click to download full resolution via product page](#)

Figure 1: Calcitriol degradation pathways and the logical decision tree for detector selection based on concentration requirements.

## Experimental Protocols

### Protocol A: USP-Aligned HPLC-UV Method (For QC)

Best for: Routine purity analysis of API and high-dose softgels.

- Column: L7 (C8) or C18, 4.6 mm × 25 cm, 5 μm (e.g., Zorbax Eclipse XDB-C18).
- Mobile Phase: Acetonitrile : Tris Buffer (1:1000) (55:45 v/v).
  - Why Tris? It maintains pH to prevent acid-catalyzed isomerization during the run.
- Flow Rate: 1.0 mL/min.
- Detection: 230 nm (per USP) or 265 nm (for max sensitivity of trienes).

- Sample Prep: Dissolve directly in Acetonitrile (maintain cool to prevent Pre-calcitriol formation).

## Protocol B: High-Sensitivity LC-MS/MS with PTAD Derivatization

Best for: Trace impurities, biological matrices, and cleaning validation swabs.

Reagents:

- PTAD Solution: 0.75 mg/mL in Acetonitrile (Prepare fresh).
- Mobile Phase A: 0.1% Formic Acid in Water.
- Mobile Phase B: 0.1% Formic Acid in Methanol.

Workflow:

- Extraction: Extract sample (e.g., plasma or swab) with Methyl tert-butyl ether (MTBE). Evaporate to dryness.
- Derivatization (The Critical Step):
  - Reconstitute residue in 50  $\mu$ L Acetonitrile.
  - Add 50  $\mu$ L PTAD Solution.
  - Vortex and incubate at Room Temperature for 20 mins (protect from light).
  - Mechanism:<sup>[3][4][5]</sup> PTAD reacts with the s-cis diene of the vitamin D backbone.
  - Quench with 10  $\mu$ L water.
- LC-MS Parameters:
  - Source: ESI Positive Mode.
  - Transitions (MRM): Monitor

592

298 (Quantifier) for Calcitriol-PTAD adduct [2].

- Column: C18 (1.9  $\mu\text{m}$ ), Gradient elution to separate the 6R and 6S diastereomers formed during derivatization.

## Conclusion & Recommendations

For routine Quality Control of raw materials where impurities are expected to be  $>0.1\%$ , HPLC-UV remains the method of choice due to its robustness and ability to quantify isomers without complex derivatization.

However, for drug development (PK studies) or trace impurity profiling (genotoxic risk assessment), LC-MS/MS with PTAD derivatization is mandatory. The sensitivity gain is not incremental; it is exponential, allowing you to see the "invisible" degradation products that UV misses.

Final Recommendation:

- Phase 1/2 QC: HPLC-UV (265 nm).
- Bioanalysis / Cleaning Validation: LC-MS/MS (+PTAD).

## References

- Duan, X., et al. "Development of a Sensitive LC/MS/MS Method for Vitamin D Metabolites Using a Novel Derivatization Agent." *Journal of Chromatography B*, vol. 878, no. 3-4, 2010. [Link](#)
- Aronov, P.A., et al. "Metabolic profiling of major vitamin D metabolites using Diels–Alder derivatization and ultra-performance liquid chromatography–tandem mass spectrometry." *Analytical and Bioanalytical Chemistry*, vol. 391, 2008, pp. 1917–1930. [Link](#)
- United States Pharmacopeia (USP). "Calcitriol Monograph." USP-NF, Current Revision. [Link](#)
- Thermo Fisher Scientific. "Calcitriol Analysis via SLE-SPE-LC-MS/MS." Application Note. [Link](#)

**Need Custom Synthesis?**

BenchChem offers custom synthesis for rare earth carbides and specific isotopic labeling.

Email: [info@benchchem.com](mailto:info@benchchem.com) or [Request Quote Online](#).

## Sources

- [1. Development of a Sensitive LC/MS/MS Method for Vitamin D Metabolites: 1,25 Dihydroxyvitamin D2&3 Measurement Using a Novel Derivatization Agent - PMC \[pmc.ncbi.nlm.nih.gov\]](#)
- [2. researchgate.net \[researchgate.net\]](#)
- [3. CN107782810A - The method for detecting calcitriol content in calcitriol soft capsule - Google Patents \[patents.google.com\]](#)
- [4. pdf.hres.ca \[pdf.hres.ca\]](#)
- [5. docs.boehringer-ingelheim.com \[docs.boehringer-ingelheim.com\]](#)
- To cite this document: BenchChem. [Comparative Guide: Detector Selection for Calcitriol Impurity Analysis]. BenchChem, [2026]. [Online PDF]. Available at: [\[https://www.benchchem.com/product/b8071406/docs#comparative-guide-detector-selection-for-calcitriol-impurity-analysis\]](https://www.benchchem.com/product/b8071406/docs#comparative-guide-detector-selection-for-calcitriol-impurity-analysis)

---

**Disclaimer & Data Validity:**

The information provided in this document is for Research Use Only (RUO) and is strictly not intended for diagnostic or therapeutic procedures. While BenchChem strives to provide accurate protocols, we make no warranties, express or implied, regarding the fitness of this product for every specific experimental setup.

**Technical Support:** The protocols provided are for reference purposes. Unsure if this reagent suits your experiment?

**Need Industrial/Bulk Grade?** [Request Custom Synthesis Quote](#)

# BenchChem

Our mission is to be the trusted global source of essential and advanced chemicals, empowering scientists and researchers to drive progress in science and industry.

## Contact

Address: 3281 E Guasti Rd

Ontario, CA 91761, United States

Phone: (601) 213-4426

Email: [info@benchchem.com](mailto:info@benchchem.com)

[Contact our Ph.D. Support Team for a compatibility check](#)