

Technical Support Center: Method Development for Separating Eprinomectin Isomers

Author: BenchChem Technical Support Team. **Date:** April 2026

Compound of Interest

Compound Name: *Eprinomectin (Standard)*

Cat. No.: *B8068675*

[Get Quote](#)

This technical support center provides troubleshooting guidance and frequently asked questions (FAQs) for researchers, scientists, and drug development professionals working on the separation of Eprinomectin isomers.

Frequently Asked Questions (FAQs)

Q1: What are the main isomers of Eprinomectin that require separation?

A1: Eprinomectin is a mixture of two primary isomers: Eprinomectin B1a and Eprinomectin B1b. Eprinomectin B1a is the major component, typically present at $\geq 90\%$, while Eprinomectin B1b is the minor component, present at $\leq 10\%$. These two isomers are homologous, differing by a single methylene group in the side chain at the C25 position.

Q2: What is the most common analytical technique for separating Eprinomectin isomers?

A2: High-Performance Liquid Chromatography (HPLC) is the most widely used and effective technique for the separation and quantification of Eprinomectin isomers.^{[1][2][3][4][5][6]}

Reversed-phase HPLC with a C18 or C8 stationary phase is the most common approach.^{[4][5][6][7]}

Q3: What are the key challenges in separating Eprinomectin isomers?

A3: The primary challenge is the structural similarity of the B1a and B1b isomers, which can lead to co-elution or poor resolution. Additionally, degradation products of Eprinomectin can interfere with the accurate quantification of the isomers, making the development of a stability-indicating method crucial. The current United States Pharmacopeia (USP) method has been reported to have limitations in separating all related impurities.[\[3\]](#)[\[4\]](#)[\[5\]](#)

Q4: What are typical mobile phases used for the separation of Eprinomectin isomers?

A4: Typical mobile phases for reversed-phase HPLC separation of Eprinomectin isomers are mixtures of an organic solvent and water. Commonly used organic solvents include acetonitrile and methanol.[\[1\]](#)[\[2\]](#)[\[6\]](#) Isocratic or gradient elution can be employed to achieve optimal separation. For example, a mobile phase consisting of acetonitrile, methanol, and water in a ratio of 47:33:20 (v/v/v) has been successfully used.[\[1\]](#)[\[2\]](#) Another reported mobile phase is a gradient of water-acetonitrile-isopropanol and acetonitrile.[\[3\]](#)[\[4\]](#)[\[5\]](#)

Q5: What detection wavelength is typically used for Eprinomectin analysis?

A5: Eprinomectin isomers are typically detected using a UV detector at a wavelength of around 245 nm or 252 nm.[\[1\]](#)[\[2\]](#)[\[3\]](#)[\[4\]](#)[\[5\]](#)[\[6\]](#)[\[7\]](#)

Troubleshooting Guide

This guide addresses common issues encountered during the HPLC separation of Eprinomectin isomers.

Problem	Potential Cause	Suggested Solution
Poor Resolution Between B1a and B1b Isomers	Inappropriate mobile phase composition.	Optimize the mobile phase by adjusting the ratio of organic solvent to water. A slight change in the percentage of acetonitrile or methanol can significantly impact resolution. Consider using a different organic modifier (e.g., methanol instead of acetonitrile) to alter selectivity.
Incorrect flow rate.	Optimize the flow rate. A lower flow rate generally improves resolution but increases run time.	
Column temperature is not optimal.	Control the column temperature using a column oven. Vary the temperature (e.g., between 25°C and 40°C) to see the effect on resolution.	
Column is old or contaminated.	Replace the column with a new one of the same type. If contamination is suspected, flush the column with a strong solvent.	
Peak Tailing	Secondary interactions with the stationary phase (silanol groups).	Use a mobile phase with a pH that suppresses the ionization of the analytes. Adding a small amount of a competing base (e.g., triethylamine) to the mobile phase can also help.
Column overload.	Reduce the sample concentration or injection volume.	

Extra-column dead volume.	Use shorter tubing with a smaller internal diameter between the injector, column, and detector.	
Peak Splitting or Shoulders	Co-elution of an impurity or degradant.	Further optimize the mobile phase to improve separation. A small change in the mobile phase composition or pH can resolve the co-eluting peaks.
Column void or contamination at the inlet.	Replace the column. If a guard column is used, replace it first.	
Sample solvent is incompatible with the mobile phase.	Dissolve the sample in the initial mobile phase whenever possible.	
Ghost Peaks	Contamination in the mobile phase, injection system, or column.	Use high-purity solvents and freshly prepared mobile phase. Flush the injector and column with a strong solvent. Run a blank gradient to identify the source of the ghost peaks.
Inconsistent Retention Times	Poor column equilibration.	Ensure the column is adequately equilibrated with the mobile phase before each injection, especially when using a gradient.
Fluctuation in mobile phase composition.	Prepare the mobile phase accurately and ensure proper mixing. If using an online mixer, check its performance.	
Temperature fluctuations.	Use a column oven to maintain a consistent temperature.	

Quantitative Data

The following table summarizes typical retention times for Eprinomectin B1a and B1b isomers from a reported HPLC method. Resolution (Rs) is a critical parameter for assessing the quality of separation and should be calculated during method validation. A resolution of >1.5 is generally considered desirable for baseline separation.

Isomer	Retention Time (minutes)
Eprinomectin B1b	2.921[7]
Eprinomectin B1a	3.748[7]

Note: Retention times can vary depending on the specific HPLC system, column, and chromatographic conditions.

Experimental Protocols

General HPLC Method for Separation of Eprinomectin Isomers

This protocol provides a starting point for developing a method to separate Eprinomectin B1a and B1b isomers. Optimization will be required for specific instrumentation and samples.

1. Instrumentation and Materials:

- HPLC system with a UV detector
- Reversed-phase C18 column (e.g., 4.6 x 150 mm, 5 µm particle size)
- Acetonitrile (HPLC grade)
- Methanol (HPLC grade)
- Water (HPLC grade)
- Eprinomectin reference standard (containing both B1a and B1b isomers)

2. Chromatographic Conditions:

- Mobile Phase: Acetonitrile:Methanol:Water (47:33:20, v/v/v)[1][2]
- Flow Rate: 1.0 mL/min (can be optimized)
- Column Temperature: 30°C
- Detection Wavelength: 245 nm[1][2][6][7]
- Injection Volume: 20 µL

3. Sample Preparation:

- Prepare a stock solution of the Eprinomectin reference standard in the mobile phase.
- Prepare working solutions by diluting the stock solution to the desired concentration range for analysis.

4. Analysis:

- Equilibrate the HPLC system with the mobile phase until a stable baseline is achieved.
- Inject the standard solutions and samples.
- Identify the peaks for Eprinomectin B1b and B1a based on their retention times.
- Calculate the resolution between the two isomer peaks.

Visualizations

Experimental Workflow for Method Development

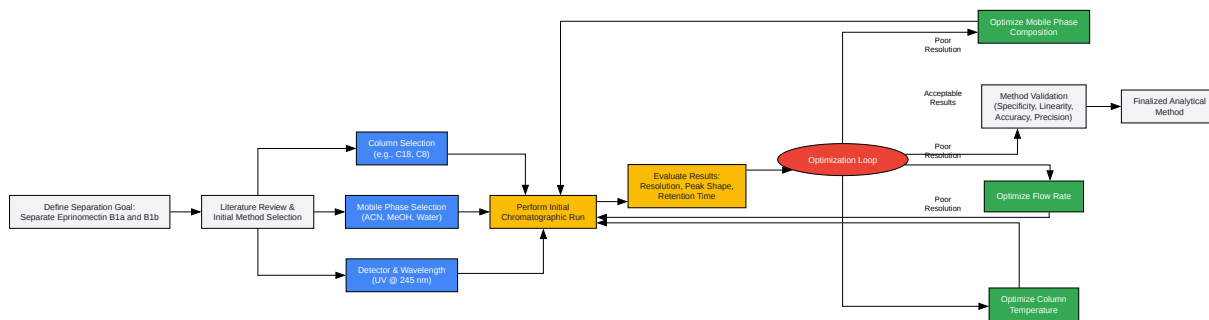

[Click to download full resolution via product page](#)

Caption: Workflow for HPLC method development for Eprinomectin isomer separation.

Troubleshooting Decision Tree for Poor Resolution



[Click to download full resolution via product page](#)

Need Custom Synthesis?

BenchChem offers custom synthesis for rare earth carbides and specific isotopic labeling.

Email: info@benchchem.com or [Request Quote Online](#).

References

- [1. provost.utsa.edu](http://provost.utsa.edu) [provost.utsa.edu]
- [2. HPLC Troubleshooting Guide](http://scioninstruments.com) [scioninstruments.com]
- [3. researchgate.net](http://researchgate.net) [researchgate.net]
- [4. researchgate.net](http://researchgate.net) [researchgate.net]
- [5. Alternative and Improved Stability-Indicating HPLC Method for the Assay of Eprinomectin and Determination of Its Related Compounds in Bulk Batches of Eprinomectin Drug Substance - PubMed](https://pubmed.ncbi.nlm.nih.gov) [pubmed.ncbi.nlm.nih.gov]
- [6. Establishment of a HPLC Method for Determination of Eprinomectin Content in an Emulsion Preparation of Eprinomectin](http://journal30.magtechjournal.com) [journal30.magtechjournal.com]
- [7. researchgate.net](http://researchgate.net) [researchgate.net]
- To cite this document: BenchChem. [Technical Support Center: Method Development for Separating Eprinomectin Isomers]. BenchChem, [2026]. [Online PDF]. Available at: [<https://www.benchchem.com/product/b8068675/docs#technical-support-center-method-development-for-separating-eprinomectin-isomers>]

Disclaimer & Data Validity:

The information provided in this document is for Research Use Only (RUO) and is strictly not intended for diagnostic or therapeutic procedures. While BenchChem strives to provide accurate protocols, we make no warranties, express or implied, regarding the fitness of this product for every specific experimental setup.

Technical Support: The protocols provided are for reference purposes. Unsure if this reagent suits your experiment?

Need Industrial/Bulk Grade? [Request Custom Synthesis Quote](#)

BenchChem

Our mission is to be the trusted global source of essential and advanced chemicals, empowering scientists and researchers to drive progress in science and industry.

Contact

Address: 3281 E Guasti Rd

Ontario, CA 91761, United States

Phone: (601) 213-4426

Email: info@benchchem.com

[Contact our Ph.D. Support Team for a compatibility check](#)