

Technical Guide: Synthesis, Properties, and Applications of Phenoxyacetic Acids

Author: BenchChem Technical Support Team. **Date:** May 2026

Compound of Interest

Compound Name: *2-(2-Hydroxy-5-nitrophenoxy)acetic acid*

Cat. No.: *B8066175*

[Get Quote](#)

Executive Summary

Phenoxyacetic acid (

) represents a privileged scaffold in organic chemistry, serving as the structural backbone for two distinct yet commercially vital classes of compounds: auxinic herbicides (e.g., 2,4-D) and lipid-lowering pharmaceuticals (e.g., fibrates). This guide analyzes the physicochemical properties, synthetic methodologies, and divergent mechanisms of action of this scaffold. It contrasts the classical Williamson ether synthesis with modern microwave-assisted green chemistry protocols and elucidates the molecular mimicry that allows these molecules to hijack signaling pathways in both plants (TIR1/AFB) and mammals (PPAR

).

Part 1: Structural Fundamentals & Physicochemical Properties

The phenoxyacetic acid core consists of a phenyl ring ether-linked to a glycolic acid moiety. The acidity of the carboxylic tail and the lipophilicity of the phenyl head are critical for bioavailability and receptor binding.

Table 1: Physicochemical Profile of Phenoxyacetic Acid (PAA)

Property	Value / Characteristic	Relevance to Application
Molecular Weight	152.15 g/mol	Small molecule, typically Lipinski rule compliant.
pKa (25°C)	3.12 – 3.17	Weak acid. Exists as an anion at physiological pH (7.4) and in phloem (pH ~8), aiding translocation in plants.
Solubility (Water)	0.1 – 0.5 g/100 mL (Cold)	Low water solubility requires formulation as salts (amine/alkali) or esters for agrochemical use.
Solubility (Organic)	High (Ethanol, Ether, Acetone)	Facilitates organic synthesis and purification via recrystallization.
Appearance	White crystalline needles	High purity indicator; melting point 98–99°C.

Part 2: Synthetic Architectures

The synthesis of phenoxyacetic acids relies fundamentally on the formation of an alkyl-aryl ether bond. While the classical Williamson synthesis remains the industrial workhorse, modern green chemistry approaches utilize microwave irradiation to overcome kinetic barriers and eliminate toxic solvents.

Comparative Synthesis Workflow

The following diagram illustrates the divergence between the classical thermodynamic route and the modern kinetic (microwave) route.

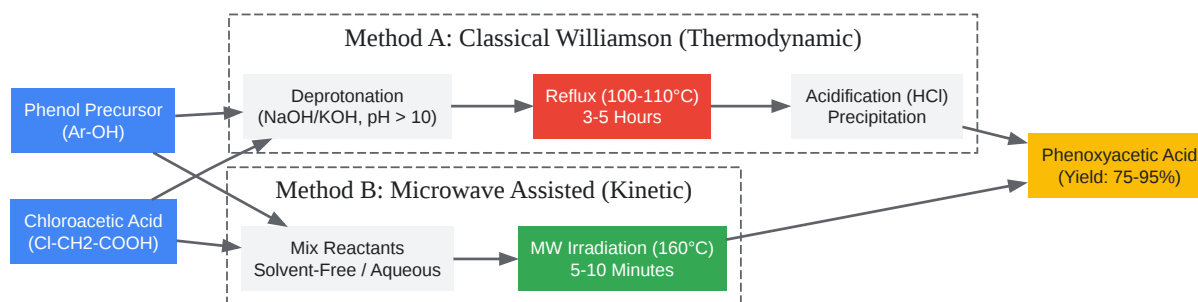

[Click to download full resolution via product page](#)

Figure 1: Comparative workflow of Classical Williamson Ether Synthesis vs. Microwave-Assisted Green Synthesis.

Experimental Protocols

Protocol A: Classical Williamson Ether Synthesis (The "Gold Standard")

Objective: Synthesis of Phenoxyacetic Acid from Phenol. Mechanism:

nucleophilic substitution.[1][2][3] The phenoxide ion attacks the -carbon of the chloroacetate.

- Reagent Preparation: In a round-bottom flask, dissolve 0.1 mol Phenol in 50 mL of 30% NaOH. The solution must be strongly alkaline to ensure complete conversion to sodium phenoxide.
- Addition: Slowly add 0.12 mol Chloroacetic acid (as sodium salt solution) to the phenoxide mixture.
 - Critical Control Point: The reaction is exothermic.[4] Maintain temperature below 60°C during addition to prevent side reactions (e.g., polymerization).
- Reflux: Heat the mixture to reflux (100–110°C) for 3 to 5 hours.

- Validation: Monitor via TLC (Solvent: Ethyl Acetate/Hexane). Disappearance of the phenol spot indicates completion.
- Isolation: Cool the mixture to room temperature. Acidify with concentrated HCl dropwise until pH reaches ~1-2.
 - Observation: A thick white precipitate (the free acid) will form immediately.
- Purification: Filter the crude solid. Recrystallize from hot water or ethanol to yield needle-like crystals.
 - Expected Yield: 70–80%.
 - Characterization: Melting point 98–99°C;
 - ¹H NMR (4.6 ppm, singlet,).

Protocol B: Microwave-Assisted Green Synthesis

Objective: Rapid, solvent-minimized synthesis. Mechanism: Direct dielectric heating of polar reagents accelerates the rate-determining step.

- Loading: In a specialized microwave process vial (e.g., 10 mL or 30 mL), load 5 mmol Phenol, 7.5 mmol Chloroacetic acid, and 10 mmol NaOH dissolved in minimal water (2-3 mL).
- Irradiation: Seal the vessel. Program the microwave reactor (e.g., Anton Paar Monowave):
 - Temperature: 140–160°C
 - Time: 5–10 minutes
 - Stirring: High (600 rpm)
- Work-up: Cool to 50°C using compressed air. Transfer to a beaker and acidify with HCl.

- Result: Filter the precipitate.
 - Advantage:^[5]^[6]^[7]^[8] Reaction time reduced from hours to minutes; yield often increases to >85% due to reduced thermal degradation time.

Part 3: Mechanism of Action & Applications

The phenoxyacetic acid scaffold is a "molecular chameleon." Its activity depends entirely on the biological context (Plant vs. Mammal) and the specific substitution pattern on the phenyl ring.

Dual Pathway Activation

The scaffold mimics endogenous signaling molecules: Indole-3-acetic acid (IAA) in plants and Fatty Acids in mammals.

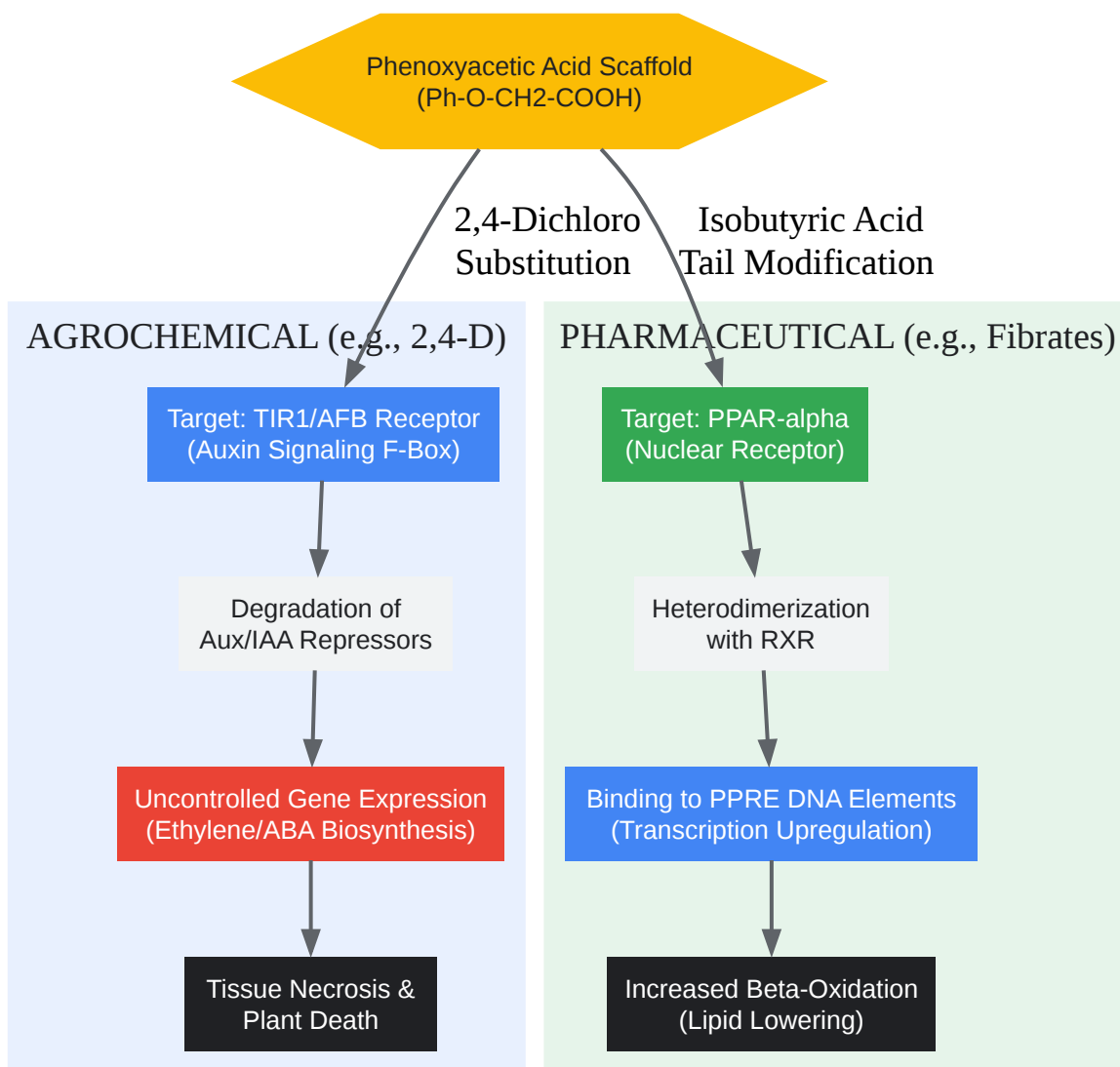

[Click to download full resolution via product page](#)

Figure 2: Divergent signaling pathways activated by Phenoxyacetic Acid derivatives in plants vs. mammals.

Structure-Activity Relationship (SAR)

Feature	Agrochemical (e.g., 2,4-D)	Pharmaceutical (e.g., Clofibrate/Fenofibrate)
Acid Head	Must be free acid or easily hydrolyzed ester. Essential for binding the "Arg-Ser-Thr" pocket in TIR1.	Often modified to isobutyric acid () to prevent metabolic degradation and improve PPAR specificity.
Linker	Ether oxygen is critical for spacing and flexibility.	Ether oxygen mimics the position of double bonds in natural fatty acids.
Phenyl Ring	2,4-dichloro substitution is optimal. Prevents ring hydroxylation (metabolism) by plants, ensuring persistence.	4-chloro or 4-benzoyl groups increase lipophilicity, aiding entry into the hepatocyte nucleus to reach PPAR receptors.
Mechanism	Auxin Overdose: Hyper-activation of growth pathways leads to structural collapse (epinasty).	Lipid Regulation: Activation of Lipoprotein Lipase (LPL) and ApoA-I/ApoA-II; reduction of VLDL.

Part 4: References

- Vogel's Textbook of Practical Organic Chemistry. (1989). Preparation of Phenoxyacetic Acid Derivatives.[\[4\]](#)[\[9\]](#)[\[10\]](#)[\[11\]](#)[\[12\]](#) Longman Scientific & Technical.
- Grossmann, K. (2010). Auxin herbicides: current status of mechanism of action. Annual Review of Plant Biology.
- Grygiel, K. et al. (2021). Conventional and Green Synthesis under Solvent-Free Microwave Irradiation of Phenoxyacetic Acid Derivatives. Farmacia Journal.

- Kappe, C. O. (2004). Controlled Microwave Heating in Modern Organic Synthesis. Angewandte Chemie International Edition.
- Fruchart, J. C., et al. (1999). Mechanism of action of fibrates on lipid and lipoprotein metabolism.[13] Circulation.
- PubChem. (2025). Phenoxyacetic Acid - Compound Summary.[14] National Library of Medicine.

Need Custom Synthesis?

BenchChem offers custom synthesis for rare earth carbides and specific isotopic labeling.

Email: info@benchchem.com or [Request Quote Online](#).

Sources

- 1. Williamson ether synthesis - Wikipedia [en.wikipedia.org]
- 2. jk-sci.com [jk-sci.com]
- 3. masterorganicchemistry.com [masterorganicchemistry.com]
- 4. Phenoxyacetic acid | 122-59-8 [chemicalbook.com]
- 5. google.com [google.com]
- 6. ajrconline.org [ajrconline.org]
- 7. mdpi.com [mdpi.com]
- 8. CN103058855A - Method for synthesizing phenoxyacetic acid derivative - Google Patents [patents.google.com]
- 9. Phenoxyacetic acid - Wikipedia [en.wikipedia.org]
- 10. Discovery and SAR of para-alkylthiophenoxyacetic acids as potent and selective PPARdelta agonists - PubMed [pubmed.ncbi.nlm.nih.gov]
- 11. pubs.acs.org [pubs.acs.org]
- 12. Phenoxyacetic Acid [drugfuture.com]
- 13. researchgate.net [researchgate.net]
- 14. farmaciajournal.com [farmaciajournal.com]

- To cite this document: BenchChem. [Technical Guide: Synthesis, Properties, and Applications of Phenoxyacetic Acids]. BenchChem, [2026]. [Online PDF]. Available at: [<https://www.benchchem.com/product/b8066175/docs#technical-guide-synthesis-properties-and-applications-of-phenoxyacetic-acids>]

Disclaimer & Data Validity:

The information provided in this document is for Research Use Only (RUO) and is strictly not intended for diagnostic or therapeutic procedures. While BenchChem strives to provide accurate protocols, we make no warranties, express or implied, regarding the fitness of this product for every specific experimental setup.

Technical Support: The protocols provided are for reference purposes. Unsure if this reagent suits your experiment?

Need Industrial/Bulk Grade? [Request Custom Synthesis Quote](#)

BenchChem

Our mission is to be the trusted global source of essential and advanced chemicals, empowering scientists and researchers to drive progress in science and industry.

Contact

Address: 3281 E Guasti Rd
Ontario, CA 91761, United States
Phone: (601) 213-4426
Email: info@benchchem.com

[Contact our Ph.D. Support Team for a compatibility check](#)