

Application Notes and Protocols for Using Virginiamycin S1 in Bacterial Selection Experiments

Author: BenchChem Technical Support Team. **Date:** April 2026

Compound of Interest

Compound Name: *Virginiamycin S1*

Cat. No.: B8066979

[Get Quote](#)

For Researchers, Scientists, and Drug Development Professionals

Introduction

Virginiamycin S1 is a member of the streptogramin B family of antibiotics, which acts as a potent inhibitor of bacterial protein synthesis. It functions synergistically with Virginiamycin M1 (a streptogramin A antibiotic) to achieve a bactericidal effect against a broad spectrum of Gram-positive bacteria. This synergistic action involves a conformational change in the bacterial ribosome, leading to the inhibition of peptide bond formation and elongation. These application notes provide detailed protocols for utilizing **Virginiamycin S1** in bacterial selection experiments, including methods for determining minimum inhibitory concentrations (MIC), assessing synergy with other antibiotics, and inducing antibiotic resistance for further study.

Mechanism of Action

Virginiamycin S1 and M1 act in a coordinated manner to inhibit bacterial protein synthesis by binding to the 50S ribosomal subunit.^{[1][2]} Virginiamycin M1 initially binds to the peptidyl transferase center (PTC) on the 23S rRNA in domain V, inducing a conformational change in

the ribosome.[3][4] This altered conformation increases the binding affinity for **Virginiamycin S1** by approximately tenfold.[2] **Virginiamycin S1** then binds to a site overlapping the PTC and extending into the nascent peptide exit tunnel (NPET).[2][5] This dual binding locks the ribosome in a non-productive conformation, blocking the attachment of aminoacyl-tRNA to the A-site and preventing the elongation of the polypeptide chain, ultimately leading to cell death.[2][5] Ribosomal proteins L18 and L22 have been identified as being at or near the **Virginiamycin S1** binding site.[6]

Data Presentation

Table 1: Minimum Inhibitory Concentration (MIC) of Virginiamycin S1 and its Synergistic Combination with Virginiamycin M1 against various Gram-positive bacteria.

Bacterial Strain	Virginiamycin S1 alone (µg/mL)	Virginiamycin M1 alone (µg/mL)	Virginiamycin M1/S1 Combination (µg/mL)
Staphylococcus aureus	4	0.25	0.125
Enterococcus faecium	>4 (resistance common)	-	8 - 32 (resistant strains)
Clostridium perfringens	-	-	MIC ₅₀ : >8, MIC ₉₀ : >8
Streptococcus pyogenes	-	-	Highly susceptible (MICs generally low)
Bacillus subtilis	Susceptible	-	-

Note: MIC values can vary depending on the specific strain and testing methodology. Data compiled from multiple sources.[7][8][9][10][11]

Table 2: Example Data Structure for Checkerboard Assay to Determine Synergy

Virginiamycin S1 (µg/mL)	Antibiotic X (µg/mL)	Growth (+/-)	FIC of Virginiamycin S1	FIC of Antibiotic X	FIC Index (FICI)	Interpretation
0.5 (MIC alone = 2)	0.25 (MIC alone = 1)	-	0.25	0.25	0.5	Synergy
...

This table illustrates the format for presenting data from a checkerboard assay. The Fractional Inhibitory Concentration (FIC) Index is calculated as: $FICI = FIC \text{ of Drug A} + FIC \text{ of Drug B}$, where $FIC = MIC \text{ of drug in combination} / MIC \text{ of drug alone}$. A FICI of ≤ 0.5 is considered synergistic.

Table 3: Example Data Structure for Time-Kill Curve Analysis

Time (hours)	Control (log ₁₀ CFU/mL)	Virginiamycin S1 (log ₁₀ CFU/mL)	Antibiotic X (log ₁₀ CFU/mL)	Virginiamycin S1 + Antibiotic X (log ₁₀ CFU/mL)
0	6.0	6.0	6.0	6.0
2	7.2	5.8	6.5	4.5
4	8.5	5.5	7.0	3.0
8	9.0	5.0	7.5	<2.0
24	9.2	4.8	7.8	<2.0

This table demonstrates how to present the results of a time-kill curve analysis. Synergy is typically defined as a ≥ 2 -log₁₀ decrease in CFU/mL between the combination and the most active single agent at a specific time point.

Experimental Protocols

Protocol 1: Determination of Minimum Inhibitory Concentration (MIC) by Broth Microdilution

This protocol determines the lowest concentration of **Virginiamycin S1** that inhibits the visible growth of a bacterium.

Materials:

- **Virginiamycin S1** stock solution (e.g., 1 mg/mL in a suitable solvent like DMSO, stored at -20°C)
- Susceptible bacterial strain (e.g., *Staphylococcus aureus* ATCC 29213)
- Cation-adjusted Mueller-Hinton Broth (CAMHB)
- Sterile 96-well microtiter plates
- Spectrophotometer
- Incubator (35-37°C)

Procedure:

- Prepare Bacterial Inoculum:
 - From a fresh (18-24 hour) culture on a non-selective agar plate, suspend several colonies in sterile saline.
 - Adjust the turbidity of the suspension to match a 0.5 McFarland standard (approximately $1-2 \times 10^8$ CFU/mL).
 - Dilute this suspension in CAMHB to achieve a final inoculum density of approximately 5×10^5 CFU/mL in the test wells.
- Prepare **Virginiamycin S1** Dilutions:

- Perform serial two-fold dilutions of the **Virginiamycin S1** stock solution in CAMHB in the 96-well plate. The final volume in each well should be 50 μ L.
- Inoculation:
 - Add 50 μ L of the prepared bacterial inoculum to each well containing the **Virginiamycin S1** dilutions.
 - Include a positive control well (100 μ L of CAMHB with 50 μ L of bacterial suspension, no antibiotic) and a negative control well (100 μ L of CAMHB only).
- Incubation:
 - Incubate the plate at 35-37°C for 16-24 hours.
- Data Analysis:
 - The MIC is the lowest concentration of **Virginiamycin S1** that completely inhibits visible growth (turbidity) as determined by visual inspection or by reading the optical density at 600 nm.

Protocol 2: Checkerboard Assay for Synergy Testing

This assay is used to evaluate the interaction between **Virginiamycin S1** and another antimicrobial agent.

Materials:

- **Virginiamycin S1** stock solution
- Stock solution of the second antibiotic (Antibiotic X)
- Susceptible bacterial strain
- CAMHB
- Sterile 96-well microtiter plates
- Multichannel pipette

Procedure:

- Prepare Antibiotic Dilutions:
 - Dispense 50 μ L of CAMHB into each well of the microtiter plate.
 - In the first row, add 50 μ L of the highest concentration of **Virginiamycin S1** to be tested and perform serial two-fold dilutions down the columns.
 - In the first column, add 50 μ L of the highest concentration of Antibiotic X to be tested and perform serial two-fold dilutions across the rows. This creates a matrix of antibiotic combinations.
- Inoculation:
 - Prepare the bacterial inoculum as described in Protocol 1.
 - Inoculate each well with 100 μ L of the bacterial suspension.
- Incubation and Data Analysis:
 - Incubate the plate at 35-37°C for 16-24 hours.
 - Determine the MIC of each antibiotic alone and in combination.
 - Calculate the Fractional Inhibitory Concentration (FIC) Index as described in the note for Table 2 to determine the nature of the interaction (synergy, additivity, indifference, or antagonism).

Protocol 3: Time-Kill Curve Analysis

This method assesses the bactericidal or bacteriostatic activity of **Virginiamycin S1** over time, alone or in combination.

Materials:

- **Virginiamycin S1** and any other test antibiotics
- Susceptible bacterial strain

- CAMHB
- Sterile culture tubes or flasks
- Shaking incubator
- Apparatus for serial dilutions and plating (e.g., agar plates, spreader)

Procedure:

- Prepare Cultures:
 - Grow the bacterial strain to the mid-logarithmic phase in CAMHB.
 - Dilute the culture to a starting inoculum of approximately 5×10^5 CFU/mL in several flasks.
- Add Antibiotics:
 - To separate flasks, add:
 - No antibiotic (growth control)
 - **Virginiamycin S1** at a predetermined concentration (e.g., 1x or 2x MIC)
 - Antibiotic X at a predetermined concentration
 - A combination of **Virginiamycin S1** and Antibiotic X
- Incubation and Sampling:
 - Incubate the flasks at 37°C with shaking.
 - At various time points (e.g., 0, 2, 4, 8, and 24 hours), withdraw an aliquot from each flask.
- Determine Viable Cell Counts:
 - Perform serial dilutions of each aliquot in sterile saline.
 - Plate the dilutions onto appropriate agar plates.

- Incubate the plates at 37°C for 18-24 hours and count the colonies to determine the CFU/mL.
- Data Analysis:
 - Plot the \log_{10} CFU/mL against time for each condition as shown in the example Table 3.

Protocol 4: Induction of Virginiamycin S1 Resistance by Serial Passage

This protocol selects for resistant mutants by gradually exposing a bacterial population to increasing concentrations of **Virginiamycin S1**.

Materials:

- Susceptible bacterial strain (e.g., *Staphylococcus aureus* or *Enterococcus faecium*)
- Liquid growth medium (e.g., CAMHB)
- **Virginiamycin S1** stock solution
- Sterile culture tubes or a 96-well plate

Procedure:

- Determine Initial MIC:
 - Perform an MIC assay (Protocol 1) to determine the baseline susceptibility of the strain.
- Serial Passage:
 - Inoculate the bacterial strain into a series of tubes or wells containing increasing concentrations of **Virginiamycin S1**, starting from a sub-inhibitory concentration (e.g., 0.5x MIC).
 - Incubate at the optimal growth temperature until turbidity is observed.

- The culture from the highest concentration of **Virginiamycin S1** that shows growth is used to inoculate a new series of cultures with a fresh, higher gradient of **Virginiamycin S1** concentrations.
- Repeat this process for a desired number of passages (e.g., 10-20).
- Isolation of Resistant Strains:
 - After the final passage, streak a sample from the culture grown in the highest **Virginiamycin S1** concentration onto an agar plate containing the same concentration of the antibiotic to isolate single colonies.
- Characterization of Resistance:
 - Determine the new MIC of the isolated colonies to quantify the level of resistance.
 - Perform genomic sequencing to identify potential resistance-conferring mutations.^[1]

Visualizations

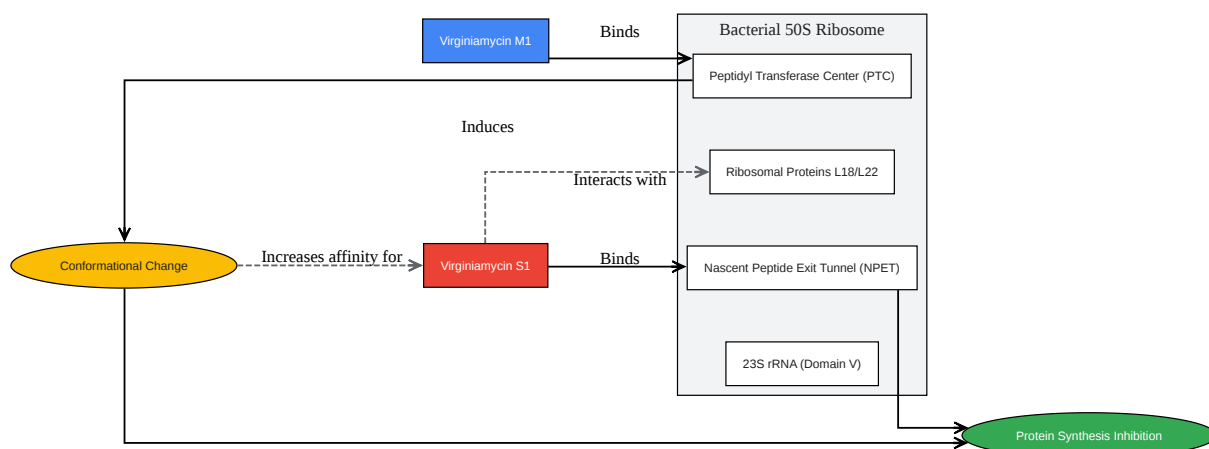

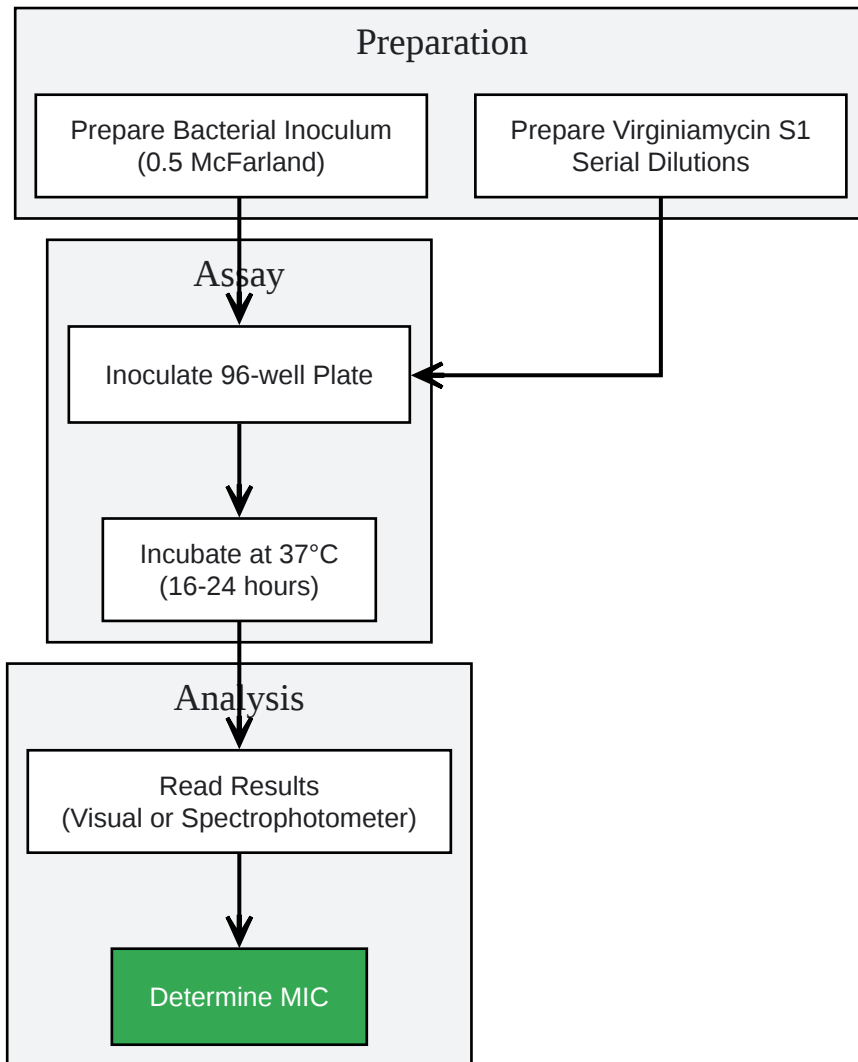

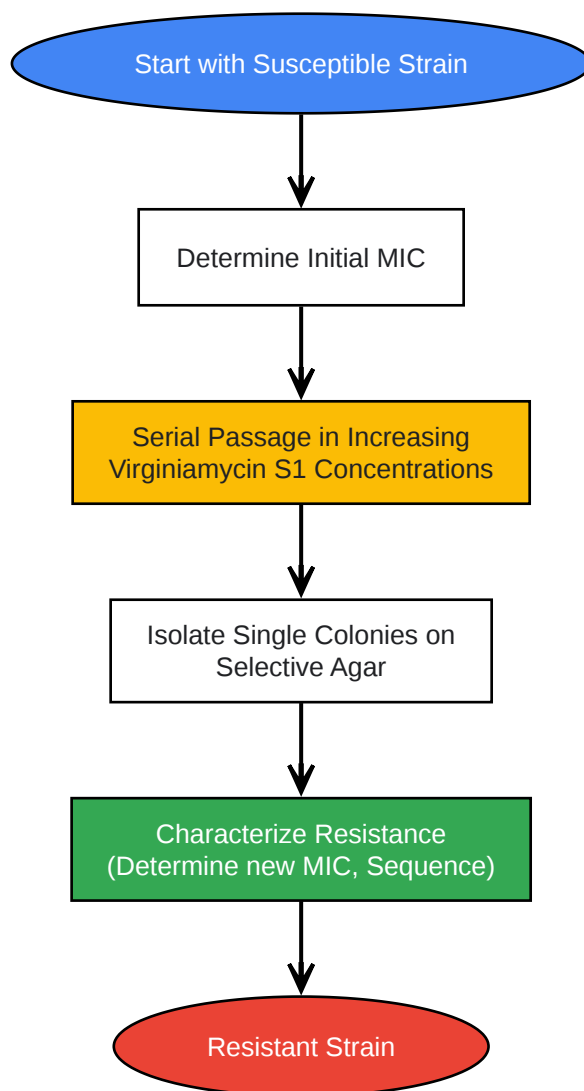

[Click to download full resolution via product page](#)

Need Custom Synthesis?

BenchChem offers custom synthesis for rare earth carbides and specific isotopic labeling.

Email: info@benchchem.com or [Request Quote Online](#).

References

- 1. [benchchem.com](https://www.benchchem.com) [benchchem.com]
- 2. Ribosome Protection Proteins—“New” Players in the Global Arms Race with Antibiotic-Resistant Pathogens - PMC [pmc.ncbi.nlm.nih.gov]

- [3. Chemical probing of a virginiamycin M-promoted conformational change of the peptidyl-transferase domain - PMC \[pmc.ncbi.nlm.nih.gov\]](#)
- [4. 23S ribosomal RNA - Wikipedia \[en.wikipedia.org\]](#)
- [5. 1YIT: Crystal Structure Of Virginiamycin M and S Bound To The 50S Ribosomal Subunit Of Haloarcula Marismortui \[ncbi.nlm.nih.gov\]](#)
- [6. Affinity labeling of the virginiamycin S binding site on bacterial ribosome - PubMed \[pubmed.ncbi.nlm.nih.gov\]](#)
- [7. researchgate.net \[researchgate.net\]](#)
- [8. Antimicrobial Susceptibility of Bacillus Strains Isolated from Primary Starters for African Traditional Bread Production and Characterization of the Bacitracin Operon and Bacitracin Biosynthesis - PMC \[pmc.ncbi.nlm.nih.gov\]](#)
- [9. Identification, characterization and antibiotic susceptibility testing for Bacillus species - PMC \[pmc.ncbi.nlm.nih.gov\]](#)
- [10. Antibiotic Susceptibility of Streptococcus Pyogenes Isolated from Respiratory Tract Infections in Dakar, Senegal - PMC \[pmc.ncbi.nlm.nih.gov\]](#)
- [11. researchgate.net \[researchgate.net\]](#)
- [To cite this document: BenchChem. \[Application Notes and Protocols for Using Virginiamycin S1 in Bacterial Selection Experiments\]. BenchChem, \[2026\]. \[Online PDF\]. Available at: \[https://www.benchchem.com/product/b8066979/docs#application-notes-and-protocols-for-using-virginiamycin-s1-in-bacterial-selection-experiments\]](#)

Disclaimer & Data Validity:

The information provided in this document is for Research Use Only (RUO) and is strictly not intended for diagnostic or therapeutic procedures. While BenchChem strives to provide accurate protocols, we make no warranties, express or implied, regarding the fitness of this product for every specific experimental setup.

Technical Support: The protocols provided are for reference purposes. Unsure if this reagent suits your experiment?

Need Industrial/Bulk Grade? [Request Custom Synthesis Quote](#)

BenchChem

Our mission is to be the trusted global source of essential and advanced chemicals, empowering scientists and researchers to drive progress in science and industry.

Contact

Address: 3281 E Guasti Rd
Ontario, CA 91761, United States
Phone: (601) 213-4426
Email: info@benchchem.com

[Contact our Ph.D. Support Team for a compatibility check](#)