

A Comparative Guide to Validated LC-MS Methods for Virginiamycin S1 Quantification

Author: BenchChem Technical Support Team. **Date:** April 2026

Compound of Interest

Compound Name: *Virginiamycin S1*

Cat. No.: *B8066979*

[Get Quote](#)

For Researchers, Scientists, and Drug Development Professionals

The accurate quantification of **Virginiamycin S1**, a key component of the antibiotic Virginiamycin, is crucial in various fields, including animal health, food safety, and pharmaceutical research. Liquid chromatography-mass spectrometry (LC-MS) stands as the preferred analytical technique for this purpose due to its high sensitivity and selectivity. This guide provides a comparative overview of validated LC-MS methods for the quantification of **Virginiamycin S1** in diverse matrices, supported by experimental data to aid researchers in selecting the most appropriate method for their specific needs.

Comparative Analysis of LC-MS Methodologies

Several validated methods for the quantification of **Virginiamycin S1** have been reported, each with its own set of experimental parameters and performance characteristics. The following table summarizes the key quantitative data from different studies to facilitate a direct comparison.

| Parameter | Method 1: Livestock & Poultry Products[1][2] | Method 2: Distillers Grains[3][4] | Method 3: Porcine Tissues[5] |
|--|--|--------------------------------------|--------------------------------------|
| Linearity (µg/L) | 0.15-10.0 | Not Specified | Not Specified |
| Correlation Coefficient (r ²) | > 0.999[1][2] | Not Specified | Not Specified |
| Limit of Quantification (LOQ) | 0.25 µg/kg[1][2] | Not Specified | ≥2 ng/g (for Virginiamycin M1)[5] |
| Average Recovery (%) | 71.2 - 98.4[1][2] | 53 - 106[3] | Not Specified |
| Relative Standard Deviation (RSD) (%) | 3.6 - 15.4[1][2] | Not Specified | Not Specified |
| Internal Standard | External Standard Method[1][2] | Virginiamycin M1- d2[4] | Not Specified |

Experimental Workflows and Protocols

The successful implementation of an LC-MS method relies on a well-defined experimental workflow, from sample preparation to data acquisition. The following diagram illustrates a general workflow for the validation of an LC-MS method for **Virginiamycin S1** quantification.

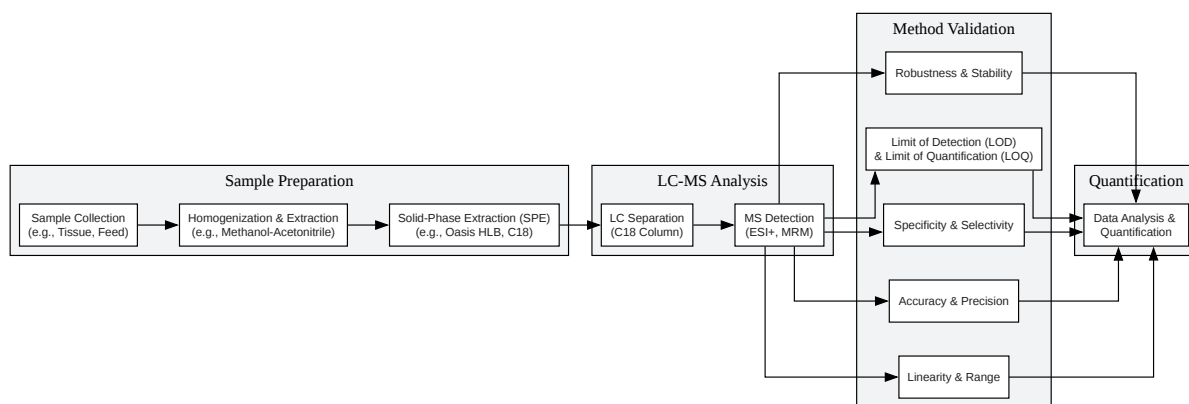

[Click to download full resolution via product page](#)

Caption: General workflow for LC-MS method validation.

Detailed Experimental Protocols

Below are detailed methodologies from the compared studies, providing a practical guide for researchers.

Method 1: Quantification in Livestock and Poultry Products[1][2]

- Sample Preparation:
 - Extract the sample with a methanol-acetonitrile solution (1:1, v/v).
 - Dilute the supernatant with 0.01 mol/L ammonium dihydrogen phosphate solution.

- Purify and concentrate the extract using an Oasis HLB solid-phase extraction (SPE) cartridge.
- Liquid Chromatography:
 - Column: Luna C18.
 - Mobile Phase: A gradient of acetonitrile and 5 mmol/L ammonium acetate aqueous solution containing 0.1% (v/v) formic acid.
- Mass Spectrometry:
 - Ionization: Positive electrospray ionization (ESI+).
 - Mode: Multiple Reaction Monitoring (MRM).
 - Quantification: External standard method.

Method 2: Quantification in Distillers Grains[3][4]

- Sample Preparation:
 - Extract residues from distillers grains with a mixture of acetonitrile and buffer, followed by an additional acetonitrile extraction.
 - Dilute the combined extract with water and wash with hexane.
 - Clean up an aliquot of the extract using an Oasis HLB SPE cartridge.
- Liquid Chromatography-Tandem Mass Spectrometry (LC-MS/MS):
 - The specific chromatographic conditions were not detailed in the provided abstracts but would typically involve a C18 column and a mobile phase gradient of acetonitrile and water with a modifier like formic acid or ammonium acetate.
- Internal Standard:
 - Virginiamycin M1-d2 was utilized as an internal standard for improved quantification of Virginiamycin M1 and S1.[4]

Method 3: Quantification in Edible Porcine Tissues[5]

- Sample Preparation:
 - Homogenize porcine liver, kidney, or muscle tissue with methanol-acetonitrile.
 - After centrifugation, dilute the supernatant with phosphate buffer.
 - Clean up the extract on a C18 SPE cartridge.
 - Partition the eluate with chloroform and remove the aqueous upper layer.
 - Evaporate the chloroform and reconstitute the dried extract in the mobile phase.
- Liquid Chromatography-Mass Spectrometry (LC-MS):
 - While **Virginiamycin S1** is monitored, this method was fully validated for the quantification and confirmation of Virginiamycin M1.[5] Confirmatory analysis for samples with quantifiable levels of Virginiamycin M1 is performed by LC-MS/MS.[5]

Conclusion

The choice of an LC-MS method for **Virginiamycin S1** quantification should be guided by the specific matrix, required sensitivity, and available resources. The methods presented here demonstrate robust and reliable approaches for the analysis of **Virginiamycin S1** in various sample types. For routine analysis in food products of animal origin, the method described for livestock and poultry products offers a well-documented and validated protocol.[1][2] When dealing with complex matrices like distillers grains, the use of an isotopically labeled internal standard, as highlighted in the second method, is recommended to ensure high accuracy and precision.[4] While the third method focuses on Virginiamycin M1 in porcine tissues, its sample preparation protocol can be adapted for the analysis of **Virginiamycin S1**. [5] Researchers should carefully consider the validation parameters of each method to ensure they meet the requirements of their intended application.

Need Custom Synthesis?

BenchChem offers custom synthesis for rare earth carbides and specific isotopic labeling.

Email: info@benchchem.com or [Request Quote Online](#).

References

- 1. [Determination of virginiamycin M1 and S1 residues in livestock and poultry products by liquid chromatography-tandem mass spectrometry] - PubMed [pubmed.ncbi.nlm.nih.gov]
- 2. researchgate.net [researchgate.net]
- 3. An LC-MS/MS method for the determination of antibiotic residues in distillers grains - PubMed [pubmed.ncbi.nlm.nih.gov]
- 4. academic.oup.com [academic.oup.com]
- 5. Analytical determination of virginiamycin drug residues in edible porcine tissues by LC-MS with confirmation by LC-MS/MS - PubMed [pubmed.ncbi.nlm.nih.gov]
- To cite this document: BenchChem. [A Comparative Guide to Validated LC-MS Methods for Virginiamycin S1 Quantification]. BenchChem, [2026]. [Online PDF]. Available at: [https://www.benchchem.com/product/b8066979/docs#a-comparative-guide-to-validated-lc-ms-methods-for-virginiamycin-s1-quantification]

Disclaimer & Data Validity:

The information provided in this document is for Research Use Only (RUO) and is strictly not intended for diagnostic or therapeutic procedures. While BenchChem strives to provide accurate protocols, we make no warranties, express or implied, regarding the fitness of this product for every specific experimental setup.

Technical Support: The protocols provided are for reference purposes. Unsure if this reagent suits your experiment?

Need Industrial/Bulk Grade? [Request Custom Synthesis Quote](#)

BenchChem

Our mission is to be the trusted global source of essential and advanced chemicals, empowering scientists and researchers to drive progress in science and industry.

Contact

Address: 3281 E Guasti Rd
Ontario, CA 91761, United States
Phone: (601) 213-4426
Email: info@benchchem.com

Contact our Ph.D. Support Team for a compatibility check