

Application Notes and Protocols: Photocleavable Biotinylation for Advanced Protein Labeling

Author: BenchChem Technical Support Team. **Date:** April 2026

Compound of Interest

Compound Name: *Ppc-NB*
Cat. No.: *B8065094*

[Get Quote](#)

For Researchers, Scientists, and Drug Development Professionals

Introduction

While a specific reagent termed "**Ppc-NB**" is not found in standard scientific literature, it is likely an abbreviation for a molecule incorporating a Photophotocleavable linker and a Norbornene handle for bioorthogonal chemistry, combined with biotin for protein labeling. This document provides a comprehensive overview of the principles and applications of photocleavable (PC) biotinylation, a powerful technique for the controlled labeling and release of proteins. We will also briefly touch upon the integration of bioorthogonal handles like norbornene for multi-step labeling strategies.

Photocleavable biotin reagents offer a significant advantage over standard biotinylation methods by allowing for the gentle release of biotinylated proteins from avidin or streptavidin matrices using UV light. This is particularly useful for preserving the integrity of delicate protein

complexes and for applications in proteomics, drug discovery, and cellular imaging where spatiotemporal control of protein interactions is crucial.

Principle of Photocleavable Biotinylation

Photocleavable biotinylation reagents consist of three key components:

- **Biotin:** A vitamin with an exceptionally high affinity for avidin and streptavidin, enabling robust capture and purification.
- **Photocleavable Linker:** Typically a nitrobenzyl-based moiety that is stable under normal experimental conditions but cleaves upon exposure to UV light (usually around 365 nm).
- **Reactive Group:** A chemical group that forms a covalent bond with a specific functional group on the target protein (e.g., N-hydroxysuccinimide (NHS) ester for primary amines).

The general workflow involves labeling the protein of interest with the PC-biotin reagent, capturing the biotinylated protein on a streptavidin support, and then releasing the protein by exposing the support to UV light.

Applications in Research and Drug Development

- **Protein-Protein Interaction Studies:** Gentle elution of protein complexes from streptavidin beads, preserving weak or transient interactions for downstream analysis by mass spectrometry.
- **Cell Surface Protein Labeling and Isolation:** Spatiotemporal control over the release of captured cell surface proteins for studying dynamic cellular processes.
- **Proteomics:** Controlled release of peptides or proteins for mass spectrometry analysis, reducing contamination from the solid support.
- **Drug Target Identification:** Photo-release of small molecule-protein conjugates for identification and characterization.

Quantitative Data Summary

The efficiency of photocleavable biotinylation and subsequent release can be influenced by several factors, including the specific PC-biotin reagent used, the nature of the protein, and the conditions of UV exposure. The following table summarizes typical quantitative parameters.

Parameter	Typical Value/Range	Notes
Labeling Efficiency	50-90%	Dependent on protein concentration, buffer conditions (pH), and reagent stoichiometry.
Photocleavage Wavelength	360-365 nm	Optimal wavelength for most nitrobenzyl-based linkers.
UV Exposure Time for Cleavage	5-30 minutes	Varies with the intensity of the UV source and the specific PC-linker.
Cleavage Efficiency	70-95%	The percentage of biotinylated protein released from the streptavidin support after UV exposure.
Protein Recovery	High	Gentle elution conditions help maintain protein structure and function.

Experimental Protocols

Protocol 1: General Protein Biotinylation with a Photocleavable NHS-Ester Biotin Reagent

This protocol describes the labeling of a purified protein containing accessible primary amines (lysine residues) with a photocleavable biotin-NHS ester.

Materials:

- Purified protein of interest (in an amine-free buffer, e.g., PBS, HEPES)

- Photocleavable Biotin-NHS Ester (e.g., PC-Biotin-NHS)
- Anhydrous Dimethylformamide (DMF) or Dimethyl Sulfoxide (DMSO)
- Amine-free buffer (e.g., Phosphate-Buffered Saline, pH 7.2-8.0)
- Desalting column
- Streptavidin-agarose beads
- UV lamp (365 nm)
- Microcentrifuge tubes

Procedure:

- Protein Preparation:
 - Dissolve or dialyze the protein of interest into an amine-free buffer (e.g., PBS, pH 7.4) at a concentration of 1-5 mg/mL. Buffers containing primary amines (e.g., Tris, glycine) will compete with the labeling reaction and must be avoided.
- Reagent Preparation:
 - Immediately before use, dissolve the PC-Biotin-NHS ester in a small amount of anhydrous DMF or DMSO to a final concentration of 10 mM.
- Biotinylation Reaction:
 - Add a 10- to 20-fold molar excess of the dissolved PC-Biotin-NHS ester to the protein solution.
 - Incubate the reaction mixture for 1-2 hours at room temperature or for 2-4 hours on ice, with gentle mixing.
- Removal of Excess Biotin:

- Remove non-reacted PC-biotin reagent using a desalting column equilibrated with the desired buffer (e.g., PBS).
- Capture of Biotinylated Protein:
 - Add the biotinylated protein solution to a slurry of streptavidin-agarose beads.
 - Incubate for 30-60 minutes at room temperature with gentle end-over-end rotation.
 - Wash the beads 3-5 times with a suitable wash buffer (e.g., PBS with 0.1% Tween-20) to remove non-biotinylated proteins.
- Photocleavage and Elution:
 - Resuspend the streptavidin beads in a minimal volume of a suitable elution buffer.
 - Expose the bead slurry to a 365 nm UV lamp for 10-30 minutes on ice. The optimal time should be determined empirically.
 - Pellet the streptavidin beads by centrifugation and collect the supernatant containing the released protein.

Protocol 2: On-Bead Digestion of Photocleavably Biotinylated Proteins for Mass Spectrometry

This protocol is suitable for identifying proteins from a complex mixture that have been labeled with a PC-biotin reagent.

Materials:

- Streptavidin-agarose beads with captured PC-biotinylated proteins (from Protocol 1)
- Wash Buffer (e.g., 50 mM Ammonium Bicarbonate)
- Dithiothreitol (DTT)
- Iodoacetamide (IAA)

- Trypsin (mass spectrometry grade)
- UV lamp (365 nm)
- Formic Acid
- C18 desalting spin tips

Procedure:

- Washing:
 - Wash the streptavidin beads with the captured proteins extensively with Wash Buffer to remove detergents and contaminants.
- Reduction and Alkylation:
 - Resuspend the beads in Wash Buffer containing 10 mM DTT and incubate at 56°C for 30 minutes.
 - Cool to room temperature and add IAA to a final concentration of 55 mM. Incubate in the dark for 20 minutes.
- Trypsin Digestion:
 - Add trypsin to the bead slurry (enzyme-to-protein ratio of approximately 1:50).
 - Incubate overnight at 37°C with shaking.
- Photocleavage and Peptide Elution:
 - Pellet the beads and transfer the supernatant containing non-biotinylated peptides to a new tube (this fraction can be analyzed separately).
 - Wash the beads with Wash Buffer.
 - Resuspend the beads in a minimal volume of Wash Buffer.
 - Expose the bead slurry to a 365 nm UV lamp for 10-30 minutes on ice.

- Pellet the beads and collect the supernatant containing the photocleaved, formerly biotinylated peptides.
- Sample Preparation for Mass Spectrometry:
 - Acidify the eluted peptide solution with formic acid.
 - Desalt the peptides using C18 spin tips according to the manufacturer's protocol.
 - The peptides are now ready for LC-MS/MS analysis.

Visualizations

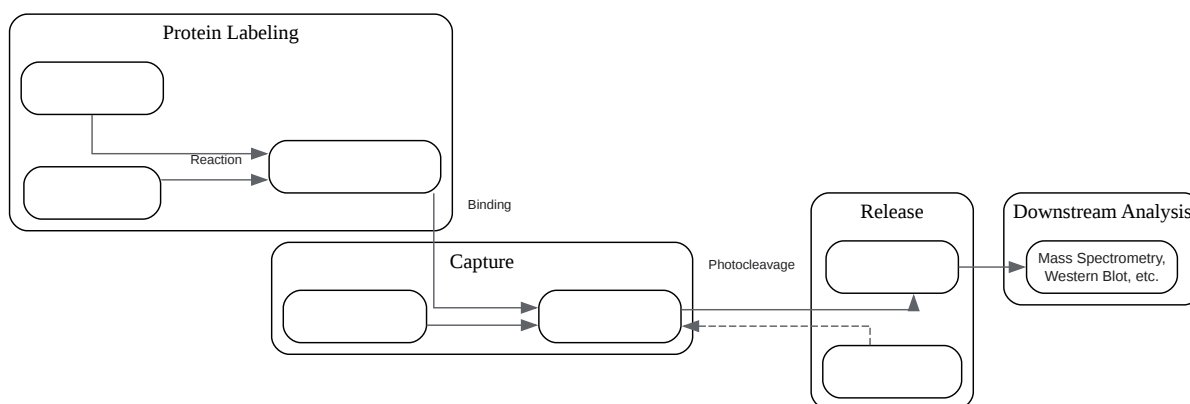

[Click to download full resolution via product page](#)

Caption: Experimental workflow for photocleavable biotinylation of proteins.

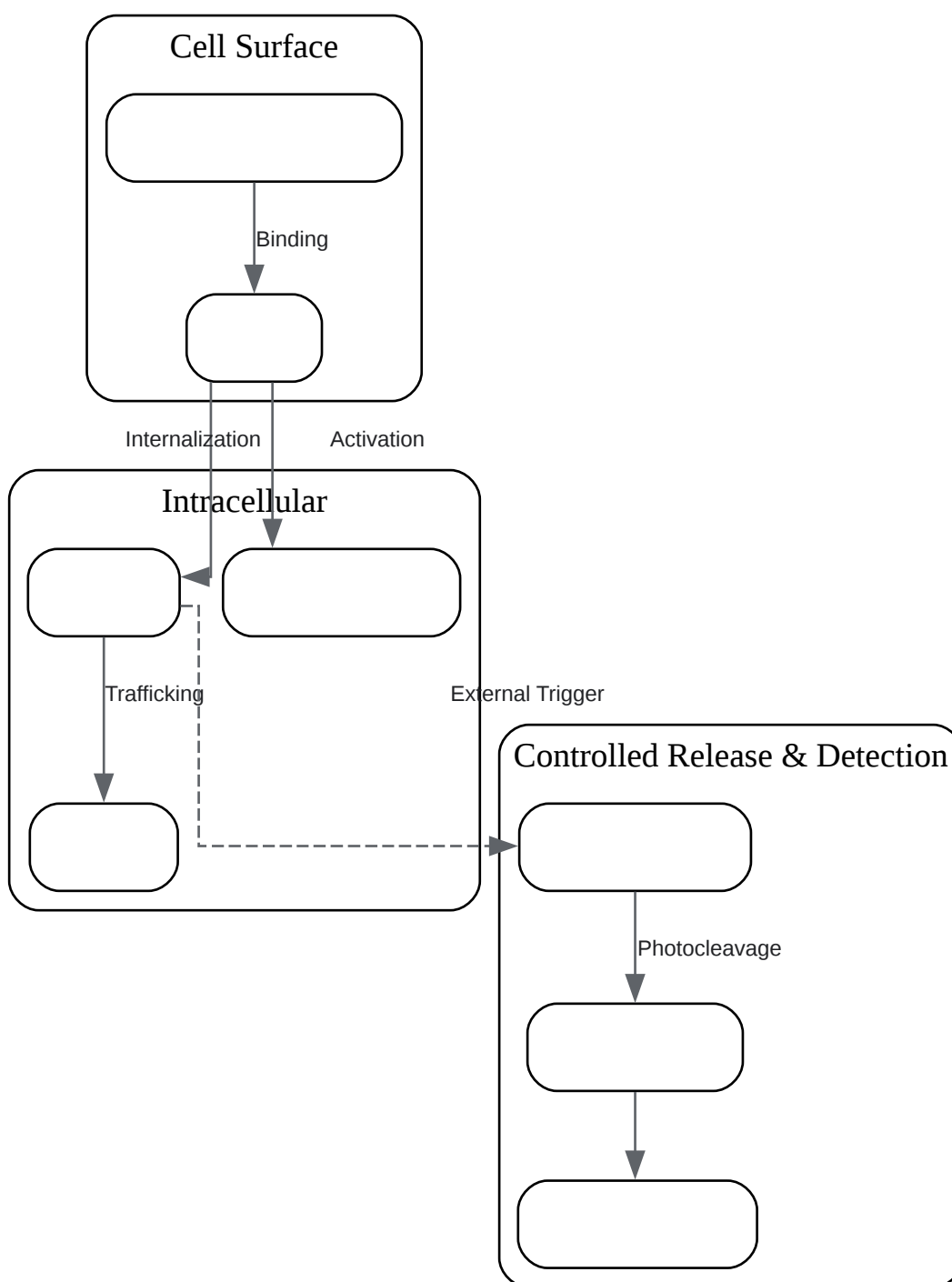

[Click to download full resolution via product page](#)

Caption: Logical diagram of using PC-biotin to study receptor trafficking.

Integration with Bioorthogonal Chemistry

The concept of a "**Ppc-NB**" reagent suggests the inclusion of a norbornene ("NB") group. Norbornene is a bioorthogonal handle that reacts specifically and rapidly with tetrazines in a bioorthogonal "click" reaction. This would enable a two-step labeling strategy:

- Initial Labeling: The protein of interest is labeled with the "**Ppc-NB-Biotin**" reagent.
- Secondary Labeling: The norbornene handle can then be reacted with a tetrazine-conjugated probe (e.g., a fluorescent dye, a drug molecule) for further functionalization.

This dual-labeling approach provides even greater versatility for complex experimental designs, allowing for both affinity capture (via biotin) and secondary labeling (via norbornene).

Disclaimer: The protocols provided are intended as a general guide. Optimization may be required for specific proteins and applications. Always refer to the manufacturer's instructions for specific reagents.

- To cite this document: BenchChem. [Application Notes and Protocols: Photocleavable Biotinylation for Advanced Protein Labeling]. BenchChem, [2026]. [Online PDF]. Available at: [<https://www.benchchem.com/product/b8065094/docs#application-notes-and-protocols-photocleavable-biotinylation-for-advanced-protein-labeling>]

Disclaimer & Data Validity:

The information provided in this document is for Research Use Only (RUO) and is strictly not intended for diagnostic or therapeutic procedures. While BenchChem strives to provide accurate protocols, we make no warranties, express or implied, regarding the fitness of this product for every specific experimental setup.

Technical Support: The protocols provided are for reference purposes. Unsure if this reagent suits your experiment?

Need Industrial/Bulk Grade? [Request Custom Synthesis Quote](#)

BenchChem

Our mission is to be the trusted global source of essential and advanced chemicals, empowering scientists and researchers to drive progress in science and industry.

Contact

Address: 3281 E Guasti Rd

Ontario, CA 91761, United States

Phone: (601) 213-4426

Email: info@benchchem.com

[Contact our Ph.D. Support Team for a compatibility check](#)