

Application Note: High-Throughput Library Synthesis Using 1-(2-Bromo-3-methylbenzyl)pyrrolidine

Author: BenchChem Technical Support Team. **Date:** April 2026

Compound of Interest

Compound Name: 1-(2-Bromo-3-methylbenzyl)pyrrolidine

Cat. No.: B8058756

[Get Quote](#)

Executive Summary

This guide details the strategic application of **1-(2-Bromo-3-methylbenzyl)pyrrolidine** as a core scaffold in Fragment-Based Drug Discovery (FBDD) and high-throughput library synthesis.

While benzylpyrrolidines are privileged structures in GPCR (e.g., antihistamines, antipsychotics) and kinase inhibitor chemistry, this specific scaffold presents a unique steric challenge. The bromine handle at the 2-position is flanked by a benzylic pyrrolidine at C1 and a methyl group at C3. This ortho-ortho' disubstitution pattern creates a sterically congested environment that inhibits oxidative addition with standard palladium catalysts (e.g., Pd(PPh₃)₄).

This protocol utilizes next-generation Buchwald precatalysts (SPhos/XPhos Pd G2) to overcome steric hindrance, ensuring high conversion rates (>95%) in parallel synthesis formats. It also details a "Catch-and-Release" purification strategy using SCX (Strong Cation Exchange) cartridges to eliminate traditional column chromatography.

Scaffold Analysis & Reactivity Mapping

Structural Properties

- CAS: [Commercial Building Block]
- Molecular Weight: ~254.17 g/mol
- Key Feature: The 2-bromo position is the diversity handle. The 3-methyl group forces the biaryl axis (formed after coupling) into a twisted conformation, often improving solubility and selectivity in protein binding pockets by restricting rotation (atropisomerism potential).

Reactivity Visualization

The following diagram maps the chemical space and steric environment of the scaffold.

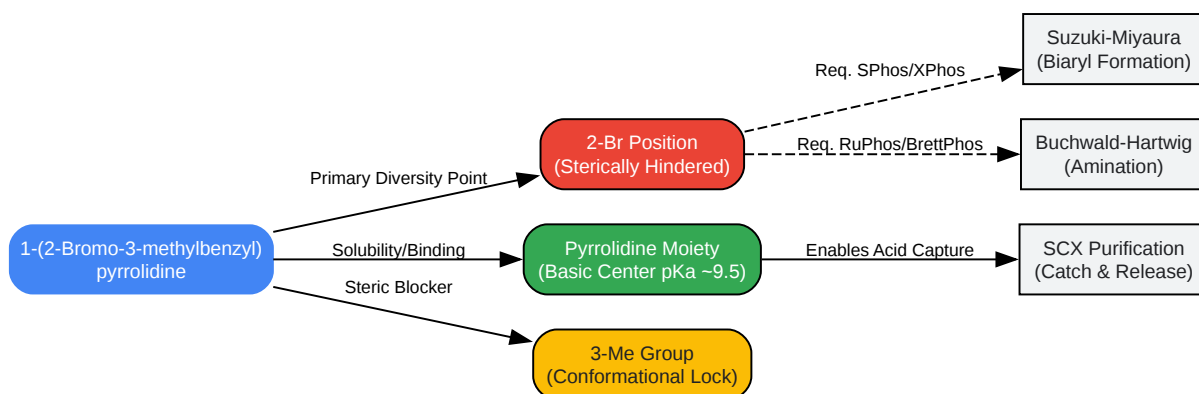

[Click to download full resolution via product page](#)

Figure 1: Reactivity map highlighting the steric congestion at the 2-Br position and the strategic utility of the basic pyrrolidine nitrogen for purification.

Protocol A: Sterically Demanding Suzuki-Miyaura Coupling

Objective: Create a library of biaryl analogs. Challenge: The 3-methyl group hinders the approach of the palladium catalyst. Solution: Use SPhos Pd G2. The SPhos ligand is electron-

rich (facilitating oxidative addition) and bulky (facilitating reductive elimination in hindered systems) [1].

Reagents & Stoichiometry

Component	Equiv.	Concentration	Role
Scaffold	1.0	0.1 M	Core building block
Boronic Acid/Ester	1.5	0.2 M	Diversity element (R-B(OH) ₂)
SPhos Pd G2	0.05	0.01 M	Precatalyst (rapid activation)
K ₃ PO ₄ (aq)	3.0	2.0 M	Base (activates boronic acid)
1,4-Dioxane	-	Solvent	Miscible with water, high boiling point

Step-by-Step Procedure (96-Well Block)

- Preparation: Dissolve the scaffold (1.0 equiv) in 1,4-dioxane.
- Dispensing: Add the scaffold solution to the reaction block containing pre-weighed boronic acids (1.5 equiv).
- Catalyst Addition: Add SPhos Pd G2 (5 mol%) as a stock solution in dioxane.
 - Note: Do not use Pd(PPh₃)₄; conversion will drop <40%.
- Base Activation: Add aqueous K₃PO₄ (3.0 equiv). The biphasic ratio should be roughly 4:1 (Organic:Aqueous).
- Reaction: Seal the block and heat at 80°C for 16 hours with vigorous shaking (800 rpm).
 - Checkpoint: Check LCMS. If protodeboronation of the boronic acid is observed, switch base to K₂CO₃ or CsF.

- Workup: Cool to RT. Separate phases. Proceed to SCX purification (Section 5).

Protocol B: Buchwald-Hartwig Amination

Objective: Introduce aniline/amine diversity at the 2-position. Challenge: Preventing β -hydride elimination and overcoming orth-sterics. Solution: Use RuPhos Pd G2 (for primary amines) or BrettPhos Pd G3 (for secondary amines) [2].

Reagents & Stoichiometry

Component	Equiv.	Role
Scaffold	1.0	Core building block
Amine (HNR ₂)	1.2	Diversity element
RuPhos Pd G2	0.05	Catalyst (Primary amines)
NaOtBu	2.0	Strong Base
t-Amyl Alcohol	-	Solvent (High temp stability)

Step-by-Step Procedure

- Inert Atmosphere: This reaction is O₂/H₂O sensitive. Purge reaction vials with Nitrogen/Argon.
- Solids: Weigh scaffold, amine (if solid), NaOtBu, and Catalyst into the vial inside a glovebox or under a flow of inert gas.
- Solvent: Add anhydrous t-Amyl Alcohol (or Toluene).
- Reaction: Heat at 100°C for 12 hours.
 - Technical Insight: The 3-methyl group prevents planarization of the resulting aniline, potentially improving solubility but slowing the reaction rate.
- Quench: Dilute with MeOH before purification.

High-Throughput Purification: SCX "Catch-and-Release"

Because the scaffold contains a basic pyrrolidine nitrogen (pKa ~9.5), we can use Strong Cation Exchange (SCX) cartridges to separate the product from non-basic impurities (boronic acids, phenols, neutral catalyst ligands) without column chromatography [3].

SCX Workflow Diagram

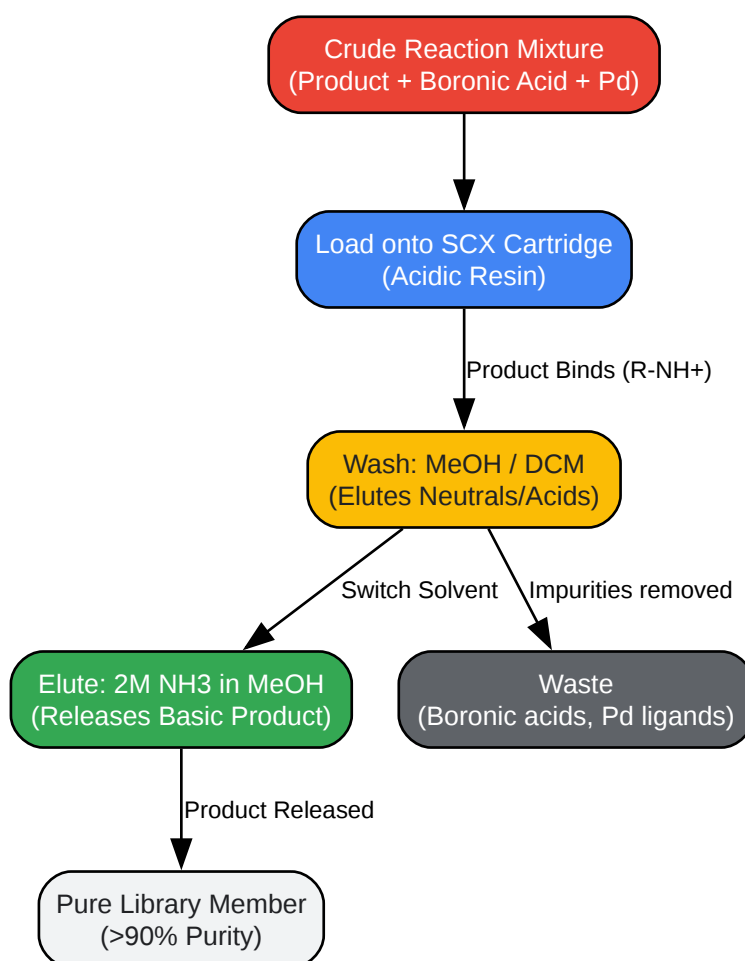

[Click to download full resolution via product page](#)

Figure 2: SCX Catch-and-Release protocol utilizing the pyrrolidine moiety for rapid purification.

Detailed Steps

- Conditioning: Pre-wet SCX cartridge (e.g., 1g sorbent) with MeOH.

- Loading: Acidify the crude reaction mixture with acetic acid (to ensure protonation of the pyrrolidine) and load onto the cartridge.
- Washing (The "Catch"): Flush with 100% MeOH (3 column volumes).
 - Result: The product remains bound to the sulfonic acid resin. Neutral impurities (excess boronic acid) and Pd-ligands are washed away.
- Elution (The "Release"): Flush with 2M NH₃ in MeOH.
 - Result: The ammonia deprotonates the pyrrolidine, releasing the free base product into the collection vial.
- Finishing: Evaporate volatiles (Genevac/SpeedVac) to yield the final compound.

References

- Martin, R., & Buchwald, S. L. (2008). Palladium-Catalyzed Suzuki-Miyaura Cross-Coupling Reactions Employing Dialkylbiaryl Phosphine Ligands. *Accounts of Chemical Research*, 41(11), 1461–1473.
- Ruiz-Castillo, P., & Buchwald, S. L. (2016). Applications of Palladium-Catalyzed C–N Cross-Coupling Reactions. *Chemical Reviews*, 116(19), 12564–12649.
- Organ, M. G., et al. (2002).[1] The use of a supported base and strong cation exchange (SCX) chromatography to prepare a variety of structurally-diverse molecular libraries. *Combinatorial Chemistry & High Throughput Screening*, 5(3), 211-218.[1]

Need Custom Synthesis?

BenchChem offers custom synthesis for rare earth carbides and specific isotopic labeling.

Email: info@benchchem.com or [Request Quote Online](#).

Sources

- [1. The use of a supported base and strong cation exchange \(SCX\) chromatography to prepare a variety of structurally-diverse molecular libraries prepared by solution-phase](#)

[methods - PubMed \[pubmed.ncbi.nlm.nih.gov\]](#)

- To cite this document: BenchChem. [Application Note: High-Throughput Library Synthesis Using 1-(2-Bromo-3-methylbenzyl)pyrrolidine]. BenchChem, [2026]. [Online PDF]. Available at: [<https://www.benchchem.com/product/b8058756/docs#application-note-high-throughput-library-synthesis-using-1-2-bromo-3-methylbenzyl-pyrrolidine>]

Disclaimer & Data Validity:

The information provided in this document is for Research Use Only (RUO) and is strictly not intended for diagnostic or therapeutic procedures. While BenchChem strives to provide accurate protocols, we make no warranties, express or implied, regarding the fitness of this product for every specific experimental setup.

Technical Support: The protocols provided are for reference purposes. Unsure if this reagent suits your experiment?

Need Industrial/Bulk Grade? [Request Custom Synthesis Quote](#)

BenchChem

Our mission is to be the trusted global source of essential and advanced chemicals, empowering scientists and researchers to drive progress in science and industry.

Contact

Address: 3281 E Guasti Rd
Ontario, CA 91761, United States
Phone: (601) 213-4426
Email: info@benchchem.com

[Contact our Ph.D. Support Team for a compatibility check](#)