

# Application Note: Strategic Functionalization of Thienopyridines

**Author:** BenchChem Technical Support Team. **Date:** May 2026

## Compound of Interest

Compound Name: Ethyl 5-bromothieno[2,3-  
c]pyridine-2-carboxylate

Cat. No.: B8053881

[Get Quote](#)

## Executive Summary & Strategic Analysis

Thienopyridines represent a "privileged scaffold" in medicinal chemistry, serving as the core for blockbuster antiplatelet agents (e.g., Clopidogrel, Prasugrel) and emerging kinase inhibitors. However, their dual-ring nature presents a unique synthetic challenge: the fusion of an electron-rich thiophene with an electron-deficient pyridine creates a reactivity dichotomy.

Successful functionalization requires a "Divide and Conquer" strategy:

- The Thiophene Ring (Electron-Rich): Susceptible to Electrophilic Aromatic Substitution (EAS) and Direct C–H Arylation.
- The Pyridine Ring (Electron-Poor): Resistant to EAS but highly reactive toward Nucleophilic Aromatic Substitution ( $S_NAr$ ) (via Halogen/N-oxide intermediates) and Radical Minisci-type alkylations.

This guide provides three field-validated protocols to access distinct chemical spaces on the thieno[2,3-b]pyridine core.

## Reactivity Map & Workflow

The following diagram illustrates the divergent reactivity profiles and the logic flow for selecting the correct protocol.

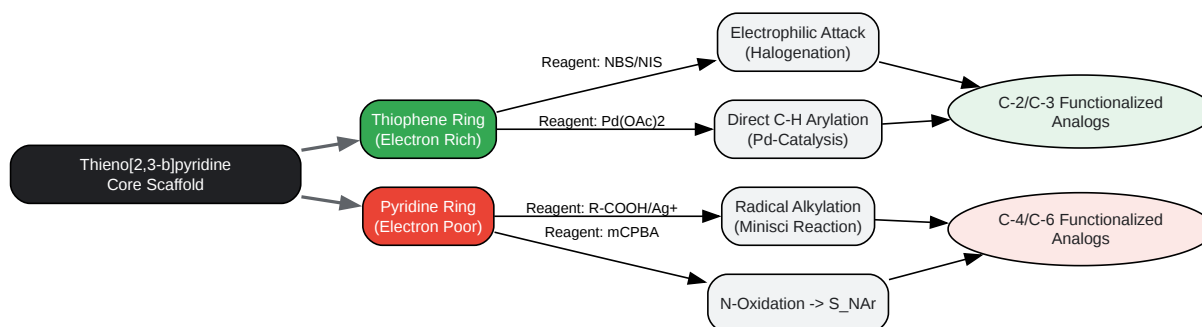

[Click to download full resolution via product page](#)

Caption: Divergent reactivity map for thieno[2,3-b]pyridine. Green path: Electrophilic/Metalation. Red path: Radical/Nucleophilic.

## Protocol A: Regioselective C-2 Bromination (The Gateway)

Objective: To install a bromine handle at the C-2 position (thiophene alpha-position) for subsequent cross-coupling (Suzuki, Buchwald). Mechanism: Electrophilic Aromatic Substitution (EAS). The sulfur atom directs electron density to C-2, making it the most nucleophilic site.

## Experimental Procedure

Reagents:

- Substrate: Thieno[2,3-b]pyridine (1.0 equiv)
- Reagent: N-Bromosuccinimide (NBS) (1.05 equiv)

- Solvent: Acetonitrile (ACN) or DMF (0.1 M concentration)
- Temperature: 0 °C to Room Temperature (RT)

#### Step-by-Step Protocol:

- Dissolution: In a round-bottom flask equipped with a magnetic stir bar, dissolve thieno[2,3-b]pyridine (1.0 mmol, 135 mg) in anhydrous ACN (10 mL).
- Cooling: Submerge the flask in an ice-water bath (0 °C) and stir for 10 minutes. Expert Insight: Cooling prevents over-bromination at C-3.
- Addition: Add NBS (1.05 mmol, 187 mg) portion-wise over 5 minutes. Protect the flask from light using aluminum foil (prevents radical side reactions).
- Reaction: Allow the mixture to warm to RT naturally. Monitor by TLC (System: 20% EtOAc/Hexanes) or LC-MS. Reaction is typically complete in 2–4 hours.
- Quench: Dilute with EtOAc (30 mL) and wash with saturated Na<sub>2</sub>S<sub>2</sub>O<sub>3</sub> (sodium thiosulfate) solution to remove excess bromine, followed by water and brine.
- Purification: Dry organic layer over Na<sub>2</sub>SO<sub>4</sub>, concentrate, and purify via silica gel flash chromatography.

#### Validation Criteria:

- <sup>1</sup>H NMR: Disappearance of the C-2 doublet (most downfield thiophene proton). The C-3 proton remains as a singlet.
- MS: Characteristic isotope pattern for Br (M+ and M+2 peaks of equal intensity).

## Protocol B: Direct C–H Arylation (Atom Economy)

Objective: To couple an aryl group directly to C-2 without pre-halogenation. Mechanism: Pd(II)/Pd(0) catalytic cycle involving Concerted Metalation-Deprotonation (CMD). This avoids the extra step of bromination.

## Experimental Procedure

## Reagents:

- Substrate: Thieno[2,3-b]pyridine (1.0 equiv)
- Coupling Partner: Aryl Bromide (Ar-Br) (1.5 equiv)
- Catalyst: Pd(OAc)<sub>2</sub> (5 mol%)
- Ligand: P(t-Bu)<sub>3</sub>·HBF<sub>4</sub> (10 mol%) or PCy<sub>3</sub>
- Base: K<sub>2</sub>CO<sub>3</sub> or Cs<sub>2</sub>CO<sub>3</sub> (2.0 equiv)[1]
- Solvent: Toluene or DMA (degassed)

## Step-by-Step Protocol:

- Setup: Charge a dried Schlenk tube or microwave vial with thieno[2,3-b]pyridine (0.5 mmol), Aryl Bromide (0.75 mmol), Pd(OAc)<sub>2</sub> (5.6 mg), Ligand (14.5 mg), and Base (138 mg K<sub>2</sub>CO<sub>3</sub>).
- Inert Atmosphere: Cap the vial and purge with Argon/Nitrogen for 3 cycles (Vacuum/Backfill).  
Trustworthiness: Oxygen is the enemy of C-H activation; thorough degassing is non-negotiable.
- Solvation: Inject anhydrous, degassed Toluene (2.5 mL) through the septum.
- Heating: Heat the sealed vessel to 100–120 °C for 16 hours. (Microwave alternative: 140 °C for 1 hour).
- Workup: Cool to RT. Filter the slurry through a pad of Celite (eluting with EtOAc) to remove inorganic salts and Palladium black.
- Purification: Concentrate filtrate and purify via column chromatography.

## Optimization Table:

Variable	Standard Condition	Alternative for Steric Bulk	Alternative for High Yield
Solvent	Toluene	DMA / DMF	Xylene
Base	K <sub>2</sub> CO <sub>3</sub>	CS <sub>2</sub> CO <sub>3</sub>	KOAc
Ligand	P(t-Bu) <sub>3</sub>	SPhos	PPh <sub>3</sub> (requires higher loading)

## Protocol C: Radical Minisci Alkylation (Pyridine Functionalization)

Objective: To install alkyl groups on the electron-deficient pyridine ring (typically C-6 or C-4).

Mechanism: Generation of a nucleophilic alkyl radical (from a carboxylic acid) which attacks the protonated (activated) pyridine ring.

### Experimental Procedure

Reagents:

- Substrate: Thieno[2,3-b]pyridine (1.0 equiv)
- Radical Source: Alkyl Carboxylic Acid (R-COOH) (2.0–3.0 equiv)
- Oxidant: (NH<sub>4</sub>)<sub>2</sub>S<sub>2</sub>O<sub>8</sub> (Ammonium Persulfate) (2.0 equiv)
- Catalyst: AgNO<sub>3</sub> (20 mol%)
- Acid: TFA (1.0 equiv) or H<sub>2</sub>SO<sub>4</sub> (catalytic)
- Solvent: DCM/Water (biphasic 1:1)

Step-by-Step Protocol:

- Preparation: In a vial, dissolve thienopyridine (0.5 mmol) and the alkyl carboxylic acid (1.0 mmol) in DCM (2 mL) and Water (2 mL).

- Activation: Add TFA (0.5 mmol). Expert Insight: Protonation of the pyridine nitrogen lowers the LUMO energy, making the ring susceptible to nucleophilic radical attack.
- Initiation: Add AgNO<sub>3</sub> (0.1 mmol, 17 mg).
- Radical Generation: Heat the mixture to 40–50 °C. Add (NH<sub>4</sub>)<sub>2</sub>S<sub>2</sub>O<sub>8</sub> (1.0 mmol) slowly (either portion-wise or as a solution) over 20 minutes to control gas evolution (CO<sub>2</sub>).
- Monitoring: Stir vigorously for 2–4 hours. The biphasic system requires high stir rates (1000 rpm) for effective phase transfer.
- Workup: Basify with saturated NaHCO<sub>3</sub> (pH > 8) to deprotonate the pyridine. Extract with DCM (3x).
- Purification: The crude mixture often contains unreacted acid; wash with dilute NaOH if the product is non-acidic, then chromatograph.

## Troubleshooting & "The Scientist's Notebook"

Observation	Root Cause	Corrective Action
Low Yield in C-H Arylation	Catalyst Poisoning by Sulfur	Increase catalyst loading to 10 mol%; ensure S-atoms are not chelating Pd (use bulky ligands like SPhos).
Regioisomer Mix (Minisci)	Lack of Steric Control	Minisci is notoriously unselective (C-4 vs C-6). Block C-6 or use bulky radicals (t-Butyl) to favor C-4.
Over-bromination (Protocol A)	Temperature too high	Strictly maintain 0 °C. Add NBS as a solution in ACN dropwise.
Protodebromination (Suzuki)	Reductive Elimination failure	Switch to anhydrous conditions; use dry solvents and CsF as base to facilitate transmetalation.

## References

- Litvinov, V. P. (2005).[2][3] The Chemistry of Thienopyridines. ResearchGate. [Link](#)
- BenchChem. (2025).[4] Application Notes and Protocols for Suzuki Cross-Coupling Reactions Utilizing Pyridine Ligands. [Link](#)
- He, R., et al. (2022). Access to Thienopyridine and Thienoquinoline Derivatives via Site-Selective C–H Bond Functionalization and Annulation. Organic Letters. [Link](#)[5]
- Duncton, M. A. (2011). Minisci reactions: Versatile C–H functionalization for medicinal chemists. MedChemComm. [Link](#)
- Lériða, A. C., et al. (2018). The First Catalytic Direct C–H Arylation on C2 and C3 of Thiophene Ring Applied to Thieno-Pyridines. Molecules. [Link](#)

### Need Custom Synthesis?

BenchChem offers custom synthesis for rare earth carbides and specific isotopic labeling.

Email: [info@benchchem.com](mailto:info@benchchem.com) or [Request Quote Online](#).

## Sources

- 1. [pdf.benchchem.com](https://pdf.benchchem.com) [[pdf.benchchem.com](https://pdf.benchchem.com)]
- 2. [igi-global.com](https://igi-global.com) [[igi-global.com](https://igi-global.com)]
- 3. [researchgate.net](https://researchgate.net) [[researchgate.net](https://researchgate.net)]
- 4. [pdf.benchchem.com](https://pdf.benchchem.com) [[pdf.benchchem.com](https://pdf.benchchem.com)]
- 5. Access to Thienopyridine and Thienoquinoline Derivatives via Site-Selective C-H Bond Functionalization and Annulation - PubMed [[pubmed.ncbi.nlm.nih.gov](https://pubmed.ncbi.nlm.nih.gov)]
- To cite this document: BenchChem. [Application Note: Strategic Functionalization of Thienopyridines]. BenchChem, [2026]. [Online PDF]. Available at: [<https://www.benchchem.com/product/b8053881/docs#application-note-strategic-functionalization-of-thienopyridines>]

---

### Disclaimer & Data Validity:

The information provided in this document is for Research Use Only (RUO) and is strictly not intended for diagnostic or therapeutic procedures. While BenchChem strives to provide accurate protocols, we make no warranties, express or implied, regarding the fitness of this product for every specific experimental setup.

**Technical Support:** The protocols provided are for reference purposes. Unsure if this reagent suits your experiment?

**Need Industrial/Bulk Grade?** [Request Custom Synthesis Quote](#)

## BenchChem

Our mission is to be the trusted global source of essential and advanced chemicals, empowering scientists and researchers to drive progress in science and industry.

### Contact

Address: 3281 E Guasti Rd  
Ontario, CA 91761, United States  
Phone: (601) 213-4426  
Email: [info@benchchem.com](mailto:info@benchchem.com)

[Contact our Ph.D. Support Team for a compatibility check](#)