

Metabolic Stability of Oxazole vs. Thiazole Scaffolds: A Comparative Guide

Author: BenchChem Technical Support Team. **Date:** April 2026

Compound of Interest

Compound Name: 4-(tert-Butyl)oxazol-2-amine
hydrochloride

Cat. No.: B8045278

[Get Quote](#)

Executive Summary

In medicinal chemistry, the choice between oxazole and thiazole scaffolds is a critical decision point that balances metabolic stability against binding affinity and lipophilicity.

- **The Verdict:** The oxazole scaffold generally exhibits superior metabolic stability compared to the thiazole scaffold.
- **The Mechanism:** Thiazoles are highly susceptible to oxidative metabolism at the sulfur atom (S-oxidation) and the C4-C5 double bond (epoxidation), leading to ring scission and potentially reactive metabolites. The oxygen atom in oxazole is "harder" and less nucleophilic, making the ring more resistant to cytochrome P450 (CYP450) oxidation.
- **The Trade-off:** While oxazoles offer stability, thiazoles often provide higher lipophilicity and specific sulfur-mediated binding interactions (e.g., -hole bonding) that oxazoles cannot mimic.

Part 1: Physicochemical & Structural Basis

Understanding the electronic differences between oxygen and sulfur is prerequisite to predicting metabolic outcomes.

Comparative Properties Table

Feature	Oxazole Scaffold	Thiazole Scaffold	Impact on Metabolism
Heteroatom	Oxygen (O)	Sulfur (S)	S is softer, more nucleophilic, prone to oxidation.
Aromaticity	Lower	Higher	Thiazole is more aromatic but S-oxidation disrupts this system easily.
Basicity (pKa)	~0.8 (Very weak base)	~2.5 (Weak base)	Thiazole N is a better H-bond acceptor; can influence CYP binding orientation.
Lipophilicity	Lower LogP	Higher LogP	Thiazoles are more likely to be CYP substrates due to hydrophobic binding.
C-H Acidity	C2-H is acidic	C2-H is more acidic	C2 deprotonation can lead to ring-opening or specific CYP attacks.

Part 2: Mechanisms of Metabolic Instability

The primary driver of instability in these scaffolds is oxidative attack by CYP450 enzymes.

Thiazole Metabolism: The "Soft Spot" Liability

Thiazoles are notorious for two major metabolic pathways that can lead to rapid clearance and toxicity:

- S-Oxidation: The sulfur atom can be oxidized to a sulfoxide or sulfone.
- Epoxidation & Ring Scission: CYP450 attacks the C4-C5 double bond, forming an unstable epoxide. This intermediate often rearranges to form reactive -thioamides or undergoes ring scission to form thioamides, which are hepatotoxic structural alerts.

Oxazole Metabolism: The "Hard" Resistance

Oxazoles are generally resistant to direct heteroatom oxidation because the oxygen is highly electronegative (holding electrons tightly).

- C-Hydroxylation: Metabolism typically occurs at the C2 or C5 positions if they are unsubstituted.
- Ring Scission: While possible, the energy barrier for oxazole ring opening is significantly higher than for thiazole.

Visualization: Metabolic Pathways

The following diagram illustrates the divergent metabolic fates of these two scaffolds.

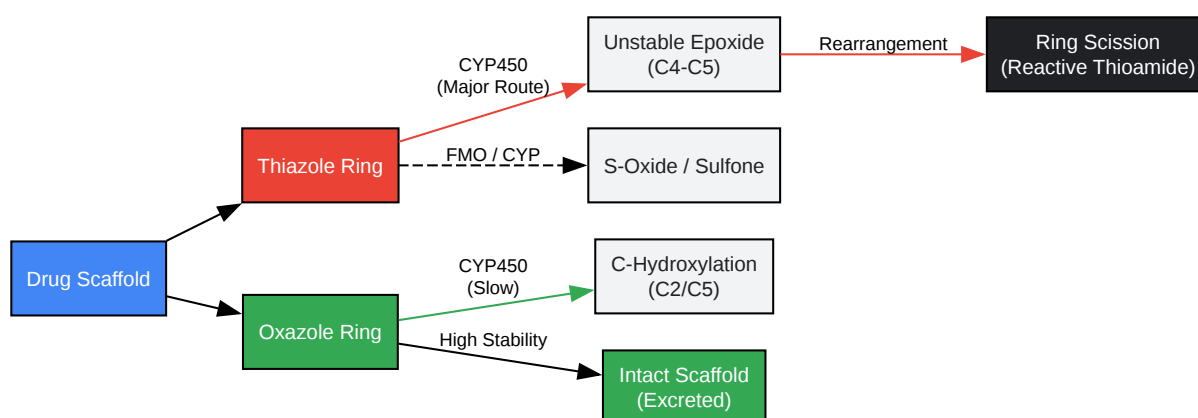

[Click to download full resolution via product page](#)

Caption: Comparative metabolic fates. Thiazoles (red path) are prone to ring scission via epoxidation, while oxazoles (green path) resist ring opening.

Part 3: Experimental Validation Protocol

To empirically verify the stability difference between an oxazole and thiazole analog, a Microsomal Stability Assay is the gold standard.

Protocol: Microsomal Stability Assay (Human Liver Microsomes - HLM)

Objective: Determine the Intrinsic Clearance (ngcontent-ng-c2977031039="" _ngghost-ng-c1310870263="" class="inline ng-star-inserted">

) and Half-life (

).

Reagents:

- Pooled Human Liver Microsomes (HLM) (20 mg/mL protein conc.)
- NADPH Regenerating System (1.3 mM NADP⁺, 3.3 mM glucose-6-phosphate, 0.4 U/mL G6P dehydrogenase, 3.3 mM MgCl₂).
- Test Compounds (Oxazole/Thiazole analogs) at 1 μM in phosphate buffer (pH 7.4).
- Stop Solution: Ice-cold Acetonitrile (ACN) containing Internal Standard (IS).

Workflow:

- Pre-incubation: Mix 30 μL of HLM (final conc. 0.5 mg/mL) with 370 μL buffer and 2 μL test compound. Incubate at 37°C for 5 min.
- Initiation: Add 100 μL of pre-warmed NADPH regenerating system to start the reaction.
- Sampling: At

min, remove 50 μL aliquots.

- Quenching: Immediately dispense aliquot into 150 μ L ice-cold Stop Solution (ACN) to precipitate proteins.
- Analysis: Centrifuge (4000 rpm, 20 min, 4°C). Analyze supernatant via LC-MS/MS (MRM mode).

Data Calculation: Plot

vs. time. The slope

is the elimination rate constant.

Visualization: Assay Workflow

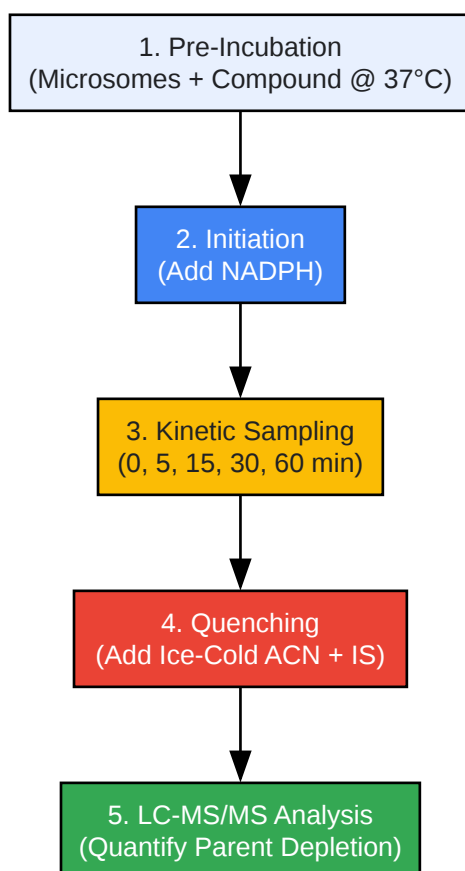

[Click to download full resolution via product page](#)

Caption: Step-by-step workflow for the Microsomal Stability Assay to determine intrinsic clearance.

Part 4: Case Studies & Data Analysis

Case Study 1: Sudoxicam vs. Meloxicam

This is the classic textbook example of thiazole metabolic liability.

- Sudoxicam: Contains an unsubstituted thiazole ring. It was withdrawn due to hepatotoxicity caused by thiourea metabolites formed via thiazole ring scission.
- Meloxicam: Structurally identical but with a methyl group at C5 of the thiazole.^[1] This methyl group sterically blocks the site of CYP epoxidation, preventing ring scission.
- Lesson: If you must use a thiazole, block the C2/C5 positions.

Case Study 2: Scaffold Hopping (Thiazole Oxazole)

In a CB2 agonist discovery program, researchers replaced a thiazole core with an oxazole to address high clearance.

Compound	Scaffold	HLM (min)	($\mu\text{L}/\text{min}/\text{mg}$)	Outcome
Cmpd A	Thiazole	12	115	High Clearance (Unstable)
Cmpd B	Oxazole	>60	<15	Low Clearance (Stable)

Analysis: The switch to oxazole eliminated the S-oxidation pathway, significantly extending the half-life without requiring steric blocking groups that might interfere with binding.

Part 5: Strategic Recommendations

- Start with Oxazole: If the heteroatom is not critical for specific binding (e.g., -hole interaction with a backbone carbonyl), prioritize oxazole for better baseline stability.

- Block the Thiazole: If thiazole is required for potency (lipophilicity), substitute the C2 and C5 positions. Avoid unsubstituted thiazoles at all costs.
- Monitor Reactive Metabolites: When using thiazoles, include a Glutathione (GSH) trapping assay in your screening cascade to detect reactive epoxide/thioamide intermediates early.

References

- Reactive Metabolites from Thiazole-Containing Drugs: Quantum Chemical Insights into Biotransformation and Toxicity. *Chemical Research in Toxicology*. (2021). [\[Link\]](#)^[2]
- Mitigating Heterocycle Metabolism in Drug Discovery. *Journal of Medicinal Chemistry*. (2012). [\[Link\]](#)
- Cytochrome P450-mediated epoxidation of 2-aminothiazole-based AKT inhibitors. *Chemical Research in Toxicology*. (2010). [\[Link\]](#)
- Scaffold-hopping as a strategy to address metabolic liabilities of aromatic compounds. *MedChemComm*. (2019). [\[Link\]](#)
- Microsomal Stability Assay Protocol. *AxisPharm*. [\[Link\]](#)

Need Custom Synthesis?

BenchChem offers custom synthesis for rare earth carbides and specific isotopic labeling.

Email: info@benchchem.com or [Request Quote Online](#).

Sources

- 1. pubs.acs.org [pubs.acs.org]
- 2. Reactive Metabolites from Thiazole-Containing Drugs: Quantum Chemical Insights into Biotransformation and Toxicity - PubMed [pubmed.ncbi.nlm.nih.gov]
- To cite this document: BenchChem. [Metabolic Stability of Oxazole vs. Thiazole Scaffolds: A Comparative Guide]. BenchChem, [2026]. [Online PDF]. Available at: [<https://www.benchchem.com/product/b8045278/docs#metabolic-stability-of-oxazole-vs-thiazole-scaffolds-a-comparative-guide>]

Disclaimer & Data Validity:

The information provided in this document is for Research Use Only (RUO) and is strictly not intended for diagnostic or therapeutic procedures. While BenchChem strives to provide accurate protocols, we make no warranties, express or implied, regarding the fitness of this product for every specific experimental setup.

Technical Support: The protocols provided are for reference purposes. Unsure if this reagent suits your experiment?

Need Industrial/Bulk Grade? [Request Custom Synthesis Quote](#)

BenchChem

Our mission is to be the trusted global source of essential and advanced chemicals, empowering scientists and researchers to drive progress in science and industry.

Contact

Address: 3281 E Guasti Rd
Ontario, CA 91761, United States
Phone: (601) 213-4426
Email: info@benchchem.com

[Contact our Ph.D. Support Team for a compatibility check](#)