

# Application Note & Protocol: Surface Functionalization of Silica Nanoparticles with Bromophenyltrichlorosilane

**Author:** BenchChem Technical Support Team. **Date:** May 2026

## Compound of Interest

Compound Name: *Bromophenyltrichlorosilane*

Cat. No.: *B8037873*

[Get Quote](#)

## Introduction: The Power of a Precisely Modified Surface

Silica nanoparticles (SiNPs) are a cornerstone of modern nanotechnology, prized for their biocompatibility, tunable size, and high surface area.<sup>[1][2][3]</sup> These properties make them exceptional candidates for a vast array of applications, from drug delivery and biomedical imaging to advanced materials and catalysis.<sup>[4][5][6][7][8]</sup> However, the true potential of SiNPs is unlocked through the precise chemical modification of their surface. Surface functionalization allows for the attachment of specific molecules, tailoring the nanoparticle's interaction with its environment and imparting new functionalities.<sup>[9][10][11][12]</sup>

This guide details a robust protocol for the covalent functionalization of SiNP surfaces with **Bromophenyltrichlorosilane**. The introduction of the bromophenyl moiety is a strategic choice for several reasons:

- **A Versatile Chemical Handle:** The bromine atom serves as an excellent leaving group for subsequent palladium-catalyzed cross-coupling reactions, such as Suzuki, Sonogashira, or

Buchwald-Hartwig amination. This opens a gateway to covalently attaching a virtually limitless range of molecules, including targeting ligands, therapeutic agents, and reporter probes.[9]

- **Tunable Hydrophobicity:** The phenyl group introduces a degree of hydrophobicity to the otherwise hydrophilic silica surface, which can be critical for applications in chromatography or for influencing interactions with biological membranes.
- **Platform for Advanced Materials:** These functionalized particles can serve as building blocks for novel hybrid organic-inorganic materials with unique electronic or optical properties.

This document provides a comprehensive, field-proven methodology for researchers, scientists, and drug development professionals, moving beyond a simple list of steps to explain the critical reasoning behind the protocol, ensuring both success and reproducibility.

## The Chemistry of Silanization: A Covalent Bond to the Surface

The covalent attachment of organosilanes to a silica surface is a well-established and reliable method for surface modification. The process hinges on the reaction between the silane and the native silanol groups (Si-OH) present on the silica nanoparticle surface.[13]

**Bromophenyltrichlorosilane** is a highly reactive agent due to its three chloro- substituents.

The mechanism proceeds in two primary stages:

- **Hydrolysis:** In the presence of trace amounts of water, the Si-Cl bonds of the trichlorosilane hydrolyze to form highly reactive silanol (Si-OH) intermediates. It is a critical aspect of this protocol to rigorously control moisture to prevent premature, uncontrolled polymerization of the silane in solution.[14][15][16][17]
- **Condensation:** These newly formed silanols on the bromophenylsilane molecule then undergo a condensation reaction with the silanol groups on the SiNP surface, forming stable, covalent siloxane (Si-O-Si) bonds.[1][17] The release of HCl as a byproduct drives the reaction forward. Due to the trifunctional nature of the silane, cross-linking between adjacent silane molecules on the surface can also occur, leading to a dense and stable organic layer.

Fig. 1: Reaction mechanism for silanization.

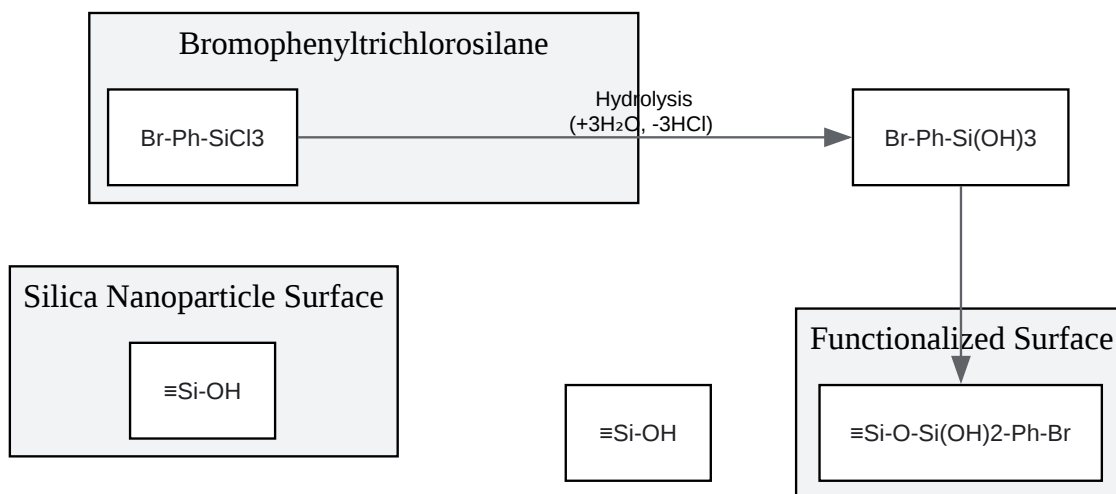

[Click to download full resolution via product page](#)

Fig. 1: Reaction mechanism for silanization.

## Detailed Experimental Protocol

This protocol is designed for the functionalization of approximately 100 mg of silica nanoparticles. Adjust volumes accordingly for different scales.

## Materials and Equipment

- Nanoparticles: 100 mg Silica Nanoparticles (non-porous, 50-100 nm diameter)
- Reagents:
  - **Bromophenyltrichlorosilane** ( $\geq 97\%$ )
  - Anhydrous Toluene ( $\geq 99.8\%$ , packaged under inert gas)
  - Concentrated Hydrochloric Acid (HCl,  $\sim 37\%$ )
  - Ethanol (Absolute,  $\geq 99.5\%$ )

- Deionized (DI) Water (18.2 MΩ·cm)
- Equipment:
  - Round-bottom flask with reflux condenser and magnetic stir bar
  - Schlenk line or glovebox for inert atmosphere operations
  - Heating mantle with temperature control
  - High-speed centrifuge with appropriate solvent-resistant tubes
  - Sonicator (bath or probe type)
  - Vacuum oven or desiccator
  - Standard laboratory glassware (graduated cylinders, beakers, etc.)
  - Personal Protective Equipment (PPE): Safety goggles, lab coat, acid-resistant gloves, fume hood.

## Step-by-Step Methodology

The entire process, from activation to final product, must be performed with care to ensure high quality and reproducibility.

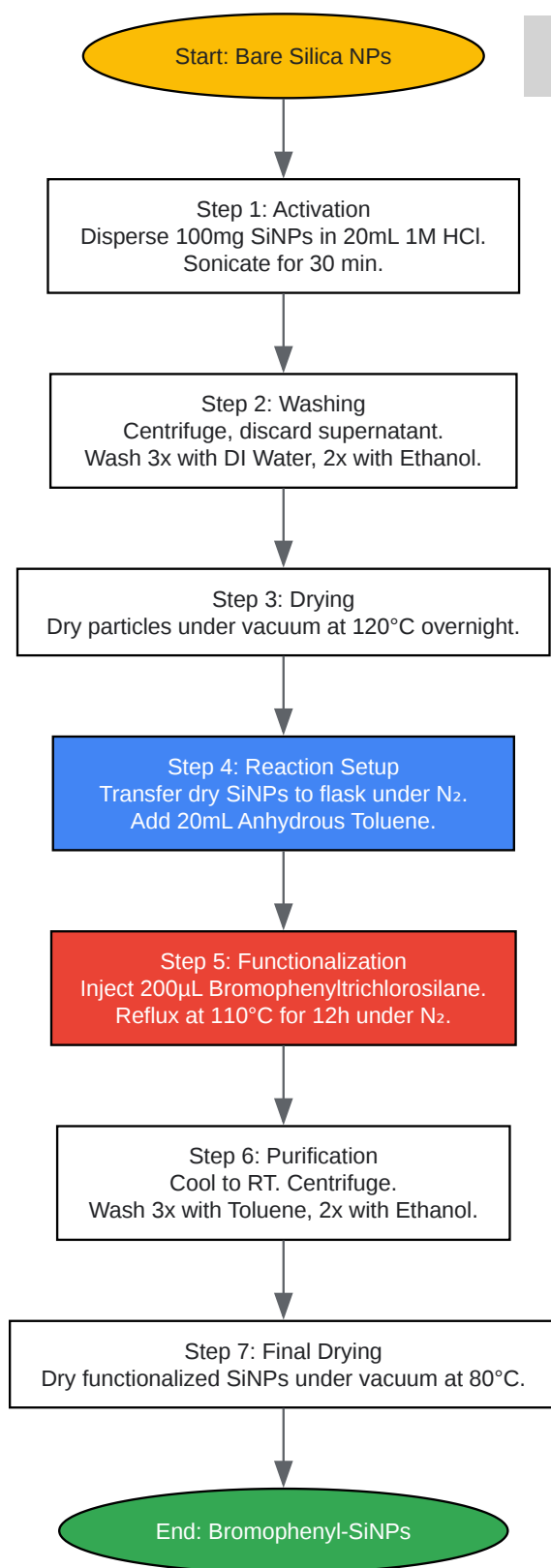

Fig. 2: Experimental workflow for functionalization.

[Click to download full resolution via product page](#)

Fig. 2: Experimental workflow for functionalization.

### Part A: Activation of Silica Nanoparticles

- Rationale: This acid wash step is crucial for removing any surface contaminants and, more importantly, for protonating and maximizing the density of reactive silanol (Si-OH) groups on the silica surface. A higher density of silanols leads to a higher degree of functionalization.
- Weigh 100 mg of silica nanoparticles and place them in a 50 mL centrifuge tube.
- Add 20 mL of 1 M HCl solution.
- Disperse the nanoparticles thoroughly using a vortex mixer, followed by sonication for 30 minutes to break up any aggregates.
- Centrifuge the suspension at 8,000 x g for 15 minutes. Carefully decant and discard the acidic supernatant.
- Re-disperse the nanoparticle pellet in 20 mL of DI water and centrifuge again. Repeat this water wash step two more times to completely remove residual acid.
- Perform two additional wash steps using 20 mL of absolute ethanol to begin the solvent exchange process.
- After the final wash, dry the activated nanoparticles in a vacuum oven at 120°C overnight. This step is critical to remove all physisorbed water, which could otherwise cause premature silane polymerization.

### Part B: Functionalization Reaction

- Rationale: This core step must be performed under strictly anhydrous and inert conditions. Toluene is an excellent high-boiling, non-polar solvent that facilitates the reaction. The reflux temperature provides the necessary activation energy for the condensation reaction. An inert nitrogen or argon atmosphere prevents atmospheric moisture from interfering with the highly sensitive trichlorosilane.
- Transfer the completely dry, activated SiNPs into a pre-dried round-bottom flask equipped with a magnetic stir bar.

- Assemble the flask with a reflux condenser and connect the setup to a Schlenk line. Evacuate and backfill the system with dry nitrogen gas three times to establish an inert atmosphere.
- Using a cannula or a dry syringe, transfer 20 mL of anhydrous toluene into the flask. Stir the suspension to fully disperse the nanoparticles.
- Using a dry, nitrogen-purged syringe, carefully inject 200  $\mu$ L of **Bromophenyltrichlorosilane** into the stirring suspension.
- Heat the reaction mixture to reflux ( $\sim 110^{\circ}\text{C}$ ) and maintain this temperature with vigorous stirring for 12 hours under a positive pressure of nitrogen.

#### Part C: Purification

- Rationale: Thorough purification is essential to remove any unreacted silane, HCl byproduct, and loosely physisorbed silane oligomers. Failure to do so will result in inaccurate characterization and poor performance in downstream applications.
- Allow the reaction mixture to cool to room temperature.
- Transfer the suspension to solvent-resistant centrifuge tubes. Centrifuge at 8,000 x g for 15 minutes. Discard the supernatant.
- Re-disperse the pellet in 20 mL of anhydrous toluene and centrifuge again. Repeat this toluene wash two more times.
- Perform two final wash steps using 20 mL of absolute ethanol to remove the toluene.
- After the final centrifugation, decant the ethanol and dry the resulting white powder (the functionalized Bromophenyl-SiNPs) in a vacuum oven at  $80^{\circ}\text{C}$  for at least 6 hours.

## Characterization and Validation

Successful functionalization must be confirmed through a suite of analytical techniques. Each method provides a piece of the puzzle to build a complete picture of the new material.

Technique	Purpose	Expected Result for Successful Functionalization
FTIR Spectroscopy	Confirms the presence of the bromophenyl group.	Appearance of new peaks corresponding to aromatic C=C stretching ( $\sim 1580\text{ cm}^{-1}$ ), aromatic C-H stretching ( $>3000\text{ cm}^{-1}$ ), and Si-Ph stretching. A noticeable decrease in the broad Si-OH peak ( $\sim 3400\text{ cm}^{-1}$ ) is also expected. <a href="#">[11]</a> <a href="#">[18]</a>
Thermogravimetric Analysis (TGA)	Quantifies the organic mass grafted onto the surface.	A distinct mass loss step between $200\text{-}600^\circ\text{C}$ corresponding to the thermal decomposition of the bromophenyl groups. The percentage of mass loss can be used to calculate the grafting density.
X-ray Photoelectron Spectroscopy (XPS)	Provides elemental analysis of the nanoparticle surface.	The appearance of a clear Bromine (Br 3d) signal confirms the presence of the functional group. The C 1s signal will also increase significantly relative to the unfunctionalized particles.
Dynamic Light Scattering (DLS)	Measures hydrodynamic diameter and polydispersity.	A slight increase in the hydrodynamic diameter is expected. A stable, low polydispersity index (PDI) indicates that no significant aggregation has occurred during the process. <a href="#">[10]</a> <a href="#">[19]</a>
Zeta Potential	Measures surface charge.	A shift in the zeta potential towards a less negative value

is expected due to the shielding of the negative silanol groups by the neutral organic layer.[20]

## Downstream Applications: A Gateway to Further Innovation

The true utility of Bromophenyl-SiNPs lies in their potential for subsequent chemical transformations, particularly palladium-catalyzed cross-coupling reactions. This transforms the nanoparticle from a simple carrier to an active participant in synthesis.

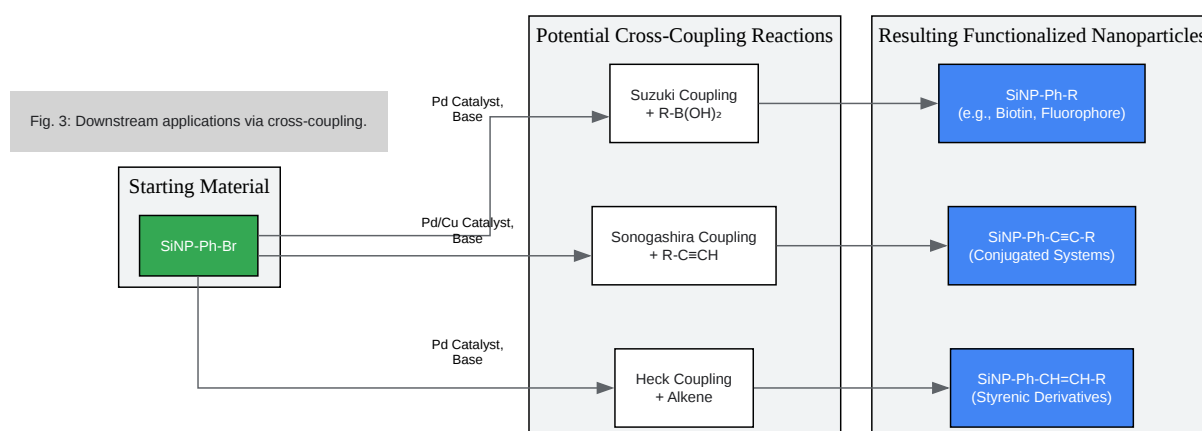

[Click to download full resolution via product page](#)

Fig. 3: Downstream applications via cross-coupling.

- Targeted Drug Delivery: A targeting ligand (e.g., folic acid, an antibody fragment) can be attached via Suzuki coupling to direct the nanoparticles to specific cells or tissues.[4][7]

- **Bio-imaging:** A fluorescent dye can be coupled to the surface for use in cellular imaging and tracking.
- **Solid-Phase Synthesis:** The nanoparticles can be used as a solid support for synthesizing complex molecules, with the final product cleaved from the surface or used while still attached.

## Troubleshooting

Problem	Potential Cause(s)	Recommended Solution(s)
Particle Aggregation	Incomplete drying before reaction; Insufficient stirring; Incorrect solvent; Excessive silane concentration.	Ensure SiNPs are completely dry. Increase stirring speed. Confirm solvent is anhydrous. Reduce the amount of silane used in the reaction.
Low Functionalization Efficiency	Incomplete activation of SiNPs; Moisture contamination during reaction; Insufficient reaction time or temperature.	Ensure proper acid wash and drying. Use high-quality anhydrous solvents and maintain a strict inert atmosphere. Extend reaction time or ensure reflux temperature is reached.
Inconsistent Batch-to-Batch Results	Variation in starting SiNPs; Inconsistent reaction conditions (moisture, temperature).	Characterize the starting SiNPs for every new batch. Standardize all procedures, especially drying steps and inert atmosphere techniques.

## Safety Precautions

- **Bromophenyltrichlorosilane:** Is highly corrosive and reacts violently with water to release HCl gas. Handle only in a fume hood under inert atmosphere. Wear appropriate PPE, including acid-resistant gloves and safety goggles.
- **Anhydrous Solvents:** Toluene is flammable and toxic. Handle with care in a well-ventilated fume hood.

- Acid Activation: Concentrated HCl is highly corrosive. Always add acid to water, never the other way around. Handle with extreme care.

## References

- Appiah Kubi, G. (2014). Functionalization of Silica Surface Using Chan-Lam Coupling. Digital Commons @ East Tennessee State University. [\[Link\]](#)
- Liberman, A., et al. (2014). Synthesis and surface functionalization of silica nanoparticles for nanomedicine. PMC - NIH. [\[Link\]](#)
- Wimmer, M., et al. (2022). Surface Functionalization of Silica Nanoparticles: Strategies to Optimize the Immune-Activating Profile of Carrier Platforms. PMC. [\[Link\]](#)
- Al-Shakarchi, W., et al. (2023). Surface Modification of Silica Particles with Adhesive Functional Groups or Their Coating with Chitosan to Improve the Retention. ACS Publications. [\[Link\]](#)
- Sang, T., et al. (2009). Functionalization of silica nanoparticles with 4-isocyanato-4'-(3,3'-dimethyl-2,4-dioxo-azetidino)diphenyl methane, surface chemical reactivity and nanohybrid preparation. PubMed. [\[Link\]](#)
- ResearchGate. (n.d.). Types of surface functionalization and encapsulation of silica nanoparticles (SiNPs) and their mechanism of uptake. ResearchGate. [\[Link\]](#)
- Hassan, M. A., et al. (2012). Adsorption of Surface Functionalized Silica Nanoparticles onto Mineral Surfaces and Decane/Water Interface. ResearchGate. [\[Link\]](#)
- Yu, H., et al. (2021). Preparation of Sulfhydryl Functionalized Mesoporous Silica Particles and Application in Adsorption of Cd<sup>2+</sup>. Semantic Scholar. [\[Link\]](#)
- Rancan, F., et al. (2021). Functionalization of photosensitized silica nanoparticles for advanced photodynamic therapy of cancer. ResearchGate. [\[Link\]](#)
- Christoforou, M., et al. (2021). Effect of Silica Nanoparticles Silanized by Functional/Functional or Functional/Non-Functional Silanes on the Physicochemical and Mechanical Properties of Dental Nanocomposite Resins. MDPI. [\[Link\]](#)

- Hayes, M. E., et al. (2015). Flavonoid adsorption and stability on titania-functionalized silica nanoparticles. ScienceDirect. [\[Link\]](#)
- Wang, Y., et al. (2022). A Review of Current Developments in Functionalized Mesoporous Silica Nanoparticles: From Synthesis to Biosensing Applications. MDPI. [\[Link\]](#)
- Wang, Y., et al. (2022). A Review of Current Developments in Functionalized Mesoporous Silica Nanoparticles: From Synthesis to Biosensing Applications. PMC. [\[Link\]](#)
- Jyothirmayi, T., et al. (2024). Recent advances in mesoporous silica nanoparticle: synthesis, drug loading, release mechanisms, and diverse applications. Frontiers. [\[Link\]](#)
- Wang, Y., et al. (2022). A Review of Current Developments in Functionalized Mesoporous Silica Nanoparticles: From Synthesis to Biosensing Applications. ResearchGate. [\[Link\]](#)
- De Bouncy, A. A., et al. (2023). Synthesis and Characterization of Functionalized Silica Particles: A Course-Based Undergraduate Research Experience in Materials Chemistry. NIH. [\[Link\]](#)
- Brinker, C. J. (1988). Hydrolysis and condensation of silicates: Effects on structure. Journal of Non-Crystalline Solids. [\[Link\]](#)
- Szigyártó, I. C., et al. (2023). Mesoporous Silica Nanoparticles as Drug Delivery Systems. PMC - NIH. [\[Link\]](#)
- Abdelmouleh, M., et al. (2002). Hydrolysis and condensation of silanes in aqueous solutions. ResearchGate. [\[Link\]](#)
- Sree, S. D., et al. (2021). Role of mesoporous silica nanoparticles for the drug delivery applications. ResearchGate. [\[Link\]](#)
- Schmidt, H., et al. (1984). PRINCIPLES OF HYDROLYSIS AND CONDENSATION REACTION OF ALKOXYSILANES. Publikationen der UdS. [\[Link\]](#)
- Brinker, C. J. (1990). CHAPTER 3 – Hydrolysis and Condensation II: Silicates. Semantic Scholar. [\[Link\]](#)

- Giram, P. S., et al. (2024). Advances in Mesoporous Silica and Hybrid Nanoparticles for Drug Delivery: Synthesis, Functionalization, and Biomedical Applications. PMC. [\[Link\]](#)
- ResearchGate. (n.d.). Hydrolysis and condensation mechanism of organofunctional silanes and bonding mechanism to a substrate. ResearchGate. [\[Link\]](#)
- Mielcarek, A., et al. (2019). Mesoporous Silica Nanoparticles for Drug Delivery: Current Insights. MDPI. [\[Link\]](#)

### Need Custom Synthesis?

BenchChem offers custom synthesis for rare earth carbides and specific isotopic labeling.

Email: [info@benchchem.com](mailto:info@benchchem.com) or [Request Quote Online](#).

## Sources

- [1. Synthesis and surface functionalization of silica nanoparticles for nanomedicine - PMC \[pmc.ncbi.nlm.nih.gov\]](#)
- [2. mdpi.com \[mdpi.com\]](#)
- [3. researchgate.net \[researchgate.net\]](#)
- [4. Frontiers | Recent advances in mesoporous silica nanoparticle: synthesis, drug loading, release mechanisms, and diverse applications \[frontiersin.org\]](#)
- [5. Mesoporous Silica Nanoparticles as Drug Delivery Systems - PMC \[pmc.ncbi.nlm.nih.gov\]](#)
- [6. researchgate.net \[researchgate.net\]](#)
- [7. Advances in Mesoporous Silica and Hybrid Nanoparticles for Drug Delivery: Synthesis, Functionalization, and Biomedical Applications - PMC \[pmc.ncbi.nlm.nih.gov\]](#)
- [8. mdpi.com \[mdpi.com\]](#)
- [9. dc.etsu.edu \[dc.etsu.edu\]](#)
- [10. Surface Functionalization of Silica Nanoparticles: Strategies to Optimize the Immune-Activating Profile of Carrier Platforms - PMC \[pmc.ncbi.nlm.nih.gov\]](#)
- [11. uhra.herts.ac.uk \[uhra.herts.ac.uk\]](#)
- [12. researchgate.net \[researchgate.net\]](#)

- [13. Synthesis and Characterization of Functionalized Silica Particles: A Course-Based Undergraduate Research Experience in Materials Chemistry - PMC \[pmc.ncbi.nlm.nih.gov\]](#)
- [14. brinkerlab.unm.edu \[brinkerlab.unm.edu\]](#)
- [15. researchgate.net \[researchgate.net\]](#)
- [16. publikationen.sulb.uni-saarland.de \[publikationen.sulb.uni-saarland.de\]](#)
- [17. researchgate.net \[researchgate.net\]](#)
- [18. Functionalization of silica nanoparticles with 4-isocyanato-4'-\(3,3'-dimethyl-2,4-dioxo-azetidino\)diphenyl methane, surface chemical reactivity and nanohybrid preparation - PubMed \[pubmed.ncbi.nlm.nih.gov\]](#)
- [19. researchgate.net \[researchgate.net\]](#)
- [20. researchgate.net \[researchgate.net\]](#)
- [To cite this document: BenchChem. \[Application Note & Protocol: Surface Functionalization of Silica Nanoparticles with Bromophenyltrichlorosilane\]. BenchChem, \[2026\]. \[Online PDF\]. Available at: \[https://www.benchchem.com/product/b8037873/docs#application-note-protocol-surface-functionalization-of-silica-nanoparticles-with-bromophenyltrichlorosilane\]](#)

---

#### Disclaimer & Data Validity:

The information provided in this document is for Research Use Only (RUO) and is strictly not intended for diagnostic or therapeutic procedures. While BenchChem strives to provide accurate protocols, we make no warranties, express or implied, regarding the fitness of this product for every specific experimental setup.

**Technical Support:** The protocols provided are for reference purposes. Unsure if this reagent suits your experiment?

**Need Industrial/Bulk Grade?** [Request Custom Synthesis Quote](#)

# BenchChem

Our mission is to be the trusted global source of essential and advanced chemicals, empowering scientists and researchers to drive progress in science and industry.

## Contact

Address: 3281 E Guasti Rd

Ontario, CA 91761, United States

Phone: (601) 213-4426

Email: [info@benchchem.com](mailto:info@benchchem.com)

[Contact our Ph.D. Support Team for a compatibility check](#)