

Application Note: Regioselective Functionalization of 6-(Benzyloxy)-3-bromo-2-fluoropyridine

Author: BenchChem Technical Support Team. **Date:** April 2026

Compound of Interest

Compound Name: 6-(Benzyloxy)-3-bromo-2-fluoropyridine

Cat. No.: B8031230

[Get Quote](#)

Introduction & Strategic Overview

The scaffold **6-(Benzyloxy)-3-bromo-2-fluoropyridine** represents a "privileged structure" in medicinal chemistry, particularly for the development of kinase inhibitors and GPCR ligands. Its value lies in its orthogonal reactivity: it possesses three distinct sites for functionalization, each responsive to specific reaction conditions.

- C2-Fluorine: Highly activated for Nucleophilic Aromatic Substitution (S_NAr).
- C3-Bromine: Excellent handle for Palladium-catalyzed cross-coupling or Lithium-Halogen exchange.
- C5-Hydrogen: Accessible via Directed Ortho Metallation (DoM) using sterically hindered bases.

- C6-Benzyloxy: A masked pyridone/hydroxyl group, serving as a directing group for lithiation before late-stage deprotection.

This guide provides validated protocols to selectively engage each site without compromising the others, enabling the construction of complex libraries from a single precursor.

Chemical Space & Reactivity Analysis

Understanding the electronic bias of the pyridine ring is prerequisite to regiocontrol.

- Electrophilicity (C2 vs. C6): The C2 position is significantly more electrophilic than C6 due to the additive inductive effects of the ring nitrogen and the adjacent C3-bromine. While the C6-benzyloxy group is electron-donating by resonance, the C2-fluorine is a potent leaving group, making C2 the exclusive site for

under mild conditions.
- Metallation Dynamics (C3 vs. C4/C5):
 - Kinetic Trap (Li-Hal Exchange): Treatment with alkylolithiums (e.g., n -BuLi) will result in rapid Lithium-Halogen exchange at C3 (min at -78°C), generating a C3-lithiated species.
 - Thermodynamic/Kinetic Control (DoM): To functionalize C5 (ortho to the directing benzyloxy group), one must use a non-nucleophilic, sterically hindered base like LiTMP (Lithium 2,2,6,6-tetramethylpiperidide) to bypass the C3-Br exchange.

Decision Logic: Functionalization Pathways

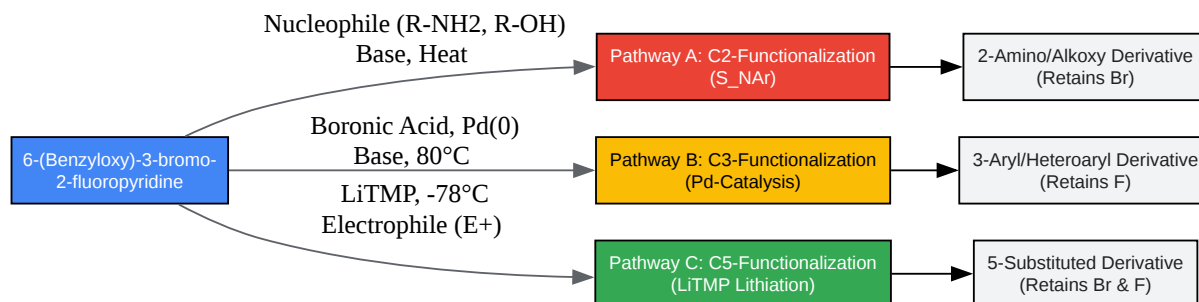

[Click to download full resolution via product page](#)

Figure 1: Divergent synthetic pathways available for the substrate. Note that Pathway A and B are generally interchangeable in sequence, while Pathway C requires the parent halide structure for optimal directing effects.

Detailed Experimental Protocols

Protocol 1: Regioselective at C2 (Displacement of Fluorine)

Objective: Introduce an amine or ether at C2 while leaving the C3-Bromine intact for subsequent coupling.

Mechanism: The reaction proceeds via a Meisenheimer complex.^{[1][2]} The C2-F bond is activated by the ring nitrogen. The C3-Br provides additional activation via inductive withdrawal, accelerating the rate compared to non-halogenated fluoropyridines.

Materials:

- Substrate: **6-(Benzyloxy)-3-bromo-2-fluoropyridine** (1.0 equiv)
- Nucleophile: Morpholine, Primary amine, or Alcohol (1.1–1.2 equiv)
- Base:

(2.0 equiv) or DIPEA (for amines); NaH (for alcohols)

- Solvent: DMSO (highly reactive) or NMP. Note: DMF can sometimes decompose at high temps.

Step-by-Step Methodology:

- Preparation: In a dry reaction vial equipped with a stir bar, dissolve the substrate (1.0 mmol) in anhydrous DMSO (3.0 mL).
- Addition: Add powdered (2.0 mmol). Then, add the amine nucleophile (1.1 mmol).
 - Critical Check: If using an alcohol, pre-form the alkoxide with NaH in THF/DMSO at 0°C before adding the pyridine substrate to avoid side reactions.
- Reaction: Heat the mixture to 60–80°C.
 - Optimization: Monitor by LCMS.[3] Conversion is typically complete within 2–4 hours.
 - Caution: Avoid temperatures >120°C to prevent potential displacement of the benzyloxy group or the bromine (though Br displacement is rare without Pd).
- Workup: Cool to room temperature. Dilute with water (15 mL) and extract with EtOAc (3 x 10 mL). Wash combined organics with brine, dry over MgSO_4 , and concentrate.[4]
- Purification: Flash chromatography (Hexanes/EtOAc).

Expected Outcome: >85% yield of the 2-substituted-3-bromo-6-(benzyloxy)pyridine.

Protocol 2: C3-Selective Suzuki-Miyaura Cross-Coupling

Objective: Couple an aryl/heteroaryl group at C3 while preserving the C2-Fluorine.

Mechanism: Oxidative addition of Pd(0) occurs preferentially at the weaker C-Br bond (BDE ~65 kcal/mol) rather than the strong C-F bond (BDE ~115 kcal/mol).

Materials:

- Substrate: **6-(Benzyloxy)-3-bromo-2-fluoropyridine** (1.0 equiv)
- Boronic Acid: Aryl-B(OH)₂ (1.2 equiv)
- Catalyst:

(5 mol%) or
- Base:

(2.0 equiv) or
- Solvent: 1,4-Dioxane/Water (4:1 ratio)

Step-by-Step Methodology:

- Degassing: Charge a microwave vial or Schlenk tube with substrate, boronic acid, base, and catalyst. Seal and purge with Argon/Nitrogen for 5 minutes.
- Solvent Addition: Add degassed Dioxane/Water mixture via syringe.
- Reaction: Heat to 80–90°C for 4–12 hours.
 - Note: The C2-F is stable under these conditions. However, avoid using strong alkoxide bases (e.g., NaOtBu) which might trigger background at C2. Carbonate bases are safe.
- Workup: Filter through a pad of Celite. Dilute with EtOAc, wash with water/brine.[\[1\]](#)
- Purification: Silica gel chromatography.

Troubleshooting:

- Hydrodehalogenation (Loss of Br): If observed, switch to anhydrous conditions (Toluene/Dioxane with anhydrous

) and ensure strict oxygen-free techniques.

Protocol 3: C5-Functionalization via Directed Ortho Metallation (DoM)

Objective: Selectively functionalize the C5 position (ortho to Benzyloxy) without touching the Br or F.

Scientific Rationale: Standard

-BuLi triggers Li-Br exchange at C3. To functionalize C5, we must use LiTMP (Lithium 2,2,6,6-tetramethylpiperidide). LiTMP is a bulky, non-nucleophilic base that is too sterically hindered to attack the Br or the pyridine ring, but strong enough (

-37) to deprotonate the C5 proton, which is acidified by the adjacent oxygen (C6-OBn) and the inductive effect of the ring.

Materials:

- Substrate: **6-(Benzyloxy)-3-bromo-2-fluoropyridine**
- Base: LiTMP (Prepared in situ from TMP and -BuLi)
- Electrophile:
, DMF, Aldehydes, etc.
- Solvent: Anhydrous THF

Step-by-Step Methodology:

- LiTMP Preparation: In a flame-dried flask under Argon, dissolve 2,2,6,6-tetramethylpiperidine (1.1 equiv) in THF at -78°C. Add -BuLi (1.1 equiv) dropwise. Warm to 0°C for 15 min, then cool back to -78°C.
- Metallation: Add the pyridine substrate (dissolved in minimal THF) dropwise to the LiTMP solution at -78°C.

- Time Control: Stir for exactly 30–45 minutes. Prolonged stirring may encourage "Halogen Dance" (migration of Br to C4/C5), although the C6-OBn directing group strongly stabilizes the C5-lithio species.
- Quench: Add the electrophile (e.g.,

in THF or dry DMF) rapidly at -78°C.
- Workup: Allow to warm to RT, quench with saturated

, and extract.

Summary of Reaction Parameters

Reaction Type	Target Site	Reagent Class	Critical Parameter	Major Risk
	C2-F	Prim/Sec Amines	Temp < 100°C	Displacement of C6-OBn (rare)
Suzuki	C3-Br	Boronic Acids	Carbonate Base	Hydrodehalogenation
DoM	C5-H	LiTMP	Temp -78°C	Li-Br Exchange (if using BuLi)
Deprotection	C6-OBn	, Pd/C or TFA	Acid vs. H ₂	Reduction of C3-Br (if using H ₂)

References

- S_NAr Reactivity of Fluoropyridines
 - Title: Nucleophilic Aromatic Substitution on Fluoropyridines: A Practical Guide.
 - Source: BenchChem Application Notes.[1]
 - Citation Context: Establishes the reactivity order C2-F >> C3-Br.
- Suzuki Coupling Selectivity

- Title: Site-selective Suzuki–Miyaura coupling of heteroaryl halides – understanding the trends for pharmaceutically important classes.
- Source: Beilstein J. Org. Chem. 2018, 14, 2384–2401.
- URL: [\[Link\]](#)
- Citation Context: Confirms preference for C-Br oxid
- Directed Ortho Metallation (DoM)
 - Title: Heteroatom-promoted lateral lithiation and Directed Ortho Metalation. [\[5\]](#)[\[6\]](#)
 - Source: Wikipedia / Organic Chemistry Portal Summaries of Schlosser/Snieckus work.
 - URL: [\[Link\]](#)
 - Citation Context: Theoretical basis for using LiTMP to avoid Li-Hal exchange in bromopyridines.
- General Reactivity of 3-Bromo-2-chloropyridines (Analogous)
 - Title: A Comparative Guide to the Suzuki-Miyaura Coupling of 3-Bromo-2-methylpyridine and 2-Bromo-3-methylpyridine. [\[7\]](#)
 - Source: BenchChem Technical Support. [\[1\]](#)[\[3\]](#)
 - Citation Context: Provides comparative data on steric and electronic effects in pyridine cross-couplings.

Need Custom Synthesis?

BenchChem offers custom synthesis for rare earth carbides and specific isotopic labeling.

Email: info@benchchem.com or [Request Quote Online](#).

Sources

- [1. pdf.benchchem.com](https://pdf.benchchem.com) [pdf.benchchem.com]
- [2. dash.harvard.edu](https://dash.harvard.edu) [dash.harvard.edu]

- [3. pdf.benchchem.com \[pdf.benchchem.com\]](https://pdf.benchchem.com)
- [4. par.nsf.gov \[par.nsf.gov\]](https://par.nsf.gov)
- [5. Heteroatom-promoted lateral lithiation - Wikipedia \[en.wikipedia.org\]](https://en.wikipedia.org)
- [6. ias.ac.in \[ias.ac.in\]](https://ias.ac.in)
- [7. pdf.benchchem.com \[pdf.benchchem.com\]](https://pdf.benchchem.com)
- To cite this document: BenchChem. [Application Note: Regioselective Functionalization of 6-(Benzyloxy)-3-bromo-2-fluoropyridine]. BenchChem, [2026]. [Online PDF]. Available at: [<https://www.benchchem.com/product/b8031230/docs#application-note-regioselective-functionalization-of-6-benzyloxy-3-bromo-2-fluoropyridine>]

Disclaimer & Data Validity:

The information provided in this document is for Research Use Only (RUO) and is strictly not intended for diagnostic or therapeutic procedures. While BenchChem strives to provide accurate protocols, we make no warranties, express or implied, regarding the fitness of this product for every specific experimental setup.

Technical Support: The protocols provided are for reference purposes. Unsure if this reagent suits your experiment?

Need Industrial/Bulk Grade? [Request Custom Synthesis Quote](#)

BenchChem

Our mission is to be the trusted global source of essential and advanced chemicals, empowering scientists and researchers to drive progress in science and industry.

Contact

Address: 3281 E Guasti Rd

Ontario, CA 91761, United States

Phone: (601) 213-4426

Email: info@benchchem.com

Contact our Ph.D. Support Team for a compatibility check