

Application Notes and Protocols: 4-Bromoanilinium Chloride in Pharmaceutical Intermediate Synthesis

Author: BenchChem Technical Support Team. **Date:** May 2026

Compound of Interest

Compound Name: 4-Bromoanilinium chloride

Cat. No.: B8028853

[Get Quote](#)

For Researchers, Scientists, and Drug Development Professionals

Introduction

4-Bromoanilinium chloride, and its free base form 4-bromoaniline, are versatile and pivotal building blocks in the synthesis of a wide array of pharmaceutical intermediates. The presence of both a reactive amino group and a bromine atom on the aromatic ring allows for diverse chemical transformations, making it an indispensable precursor for constructing complex molecular architectures found in many active pharmaceutical ingredients (APIs).[1][2] This compound serves as a key starting material for introducing the 4-aminophenyl moiety, a common structural motif in drugs targeting a range of conditions, including analgesics, antihistamines, and antipsychotics.[3]

The primary utility of **4-bromoanilinium chloride** in pharmaceutical synthesis lies in its participation in palladium-catalyzed cross-coupling reactions, such as the Suzuki-Miyaura, Buchwald-Hartwig, and Heck reactions, as well as in Mannich reactions.[4] These methodologies enable the formation of carbon-carbon and carbon-nitrogen bonds, facilitating the assembly of complex drug scaffolds.

This document provides detailed application notes and experimental protocols for two of the most critical transformations involving 4-bromoaniline in the synthesis of pharmaceutical intermediates: the Suzuki-Miyaura coupling and the Buchwald-Hartwig amination.

Key Synthetic Applications

4-Bromoaniline is a versatile substrate for several high-impact synthetic reactions in pharmaceutical development:

- **Suzuki-Miyaura Coupling:** This reaction is employed to form a carbon-carbon bond between 4-bromoaniline and a boronic acid or ester. This is a powerful method for synthesizing biaryl compounds, which are common cores in many pharmaceutical agents. The reactivity of the carbon-halogen bond in Suzuki-Miyaura reactions generally follows the trend $I > Br > Cl$.^[5]
- **Buchwald-Hartwig Amination:** This palladium-catalyzed reaction forms a carbon-nitrogen bond between 4-bromoaniline and a primary or secondary amine. It is a cornerstone for the synthesis of diarylamines and N-aryl heterocycles, which are prevalent in medicinal chemistry.^{[1][6]}
- **Heck Reaction:** This reaction involves the coupling of 4-bromoaniline with an alkene in the presence of a palladium catalyst, leading to the formation of substituted anilines.
- **Mannich Reaction:** 4-Bromoaniline can act as the amine component in the three-component Mannich reaction to produce β -amino ketones, which can be further elaborated into more complex pharmaceutical intermediates.^[4]

Experimental Protocols

Protocol 1: Suzuki-Miyaura Coupling for the Synthesis of 4'-Amino-[1,1'-biphenyl]-4-carbonitrile

This protocol details the synthesis of 4'-amino-[1,1'-biphenyl]-4-carbonitrile, a key intermediate for various pharmaceutical compounds, via a Suzuki-Miyaura coupling reaction between 4-bromoaniline and 4-cyanophenylboronic acid.

Reaction Scheme:

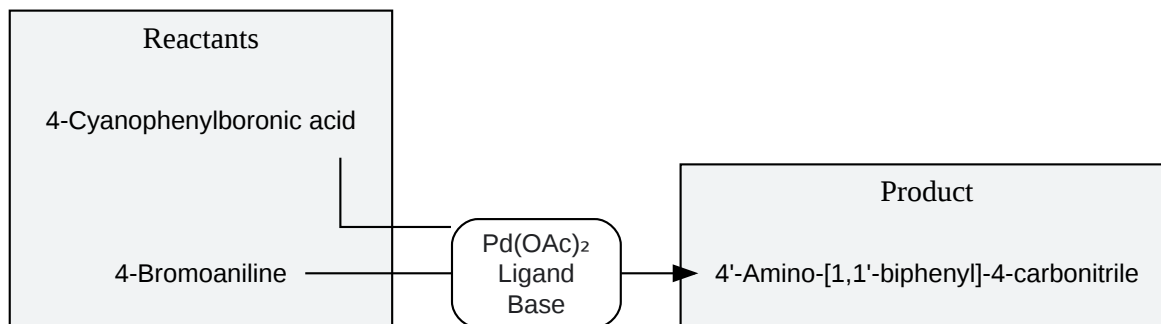

[Click to download full resolution via product page](#)

Caption: Suzuki-Miyaura coupling of 4-bromoaniline.

Materials:

Reagent/Material	Molecular Weight (g/mol)
4-Bromoaniline	172.03
4-Cyanophenylboronic acid	146.94
Palladium(II) Acetate (Pd(OAc) ₂)	224.50
Triphenylphosphine (PPh ₃)	262.29
Potassium Carbonate (K ₂ CO ₃)	138.21
1,4-Dioxane	88.11
Water	18.02
Ethyl Acetate	88.11
Brine	-
Anhydrous Sodium Sulfate	142.04

Experimental Procedure:

- To a dry Schlenk flask, add 4-bromoaniline (1.0 mmol, 172 mg), 4-cyanophenylboronic acid (1.2 mmol, 176 mg), and potassium carbonate (2.0 mmol, 276 mg).
- Add palladium(II) acetate (0.02 mmol, 4.5 mg) and triphenylphosphine (0.08 mmol, 21 mg).
- Evacuate and backfill the flask with an inert gas (e.g., nitrogen or argon) three times.
- Add 1,4-dioxane (8 mL) and water (2 mL) via syringe.
- Stir the reaction mixture at 80 °C and monitor the reaction progress by thin-layer chromatography (TLC) or liquid chromatography-mass spectrometry (LC-MS).
- Upon completion (typically 4-6 hours), cool the reaction mixture to room temperature.
- Dilute the mixture with ethyl acetate (20 mL) and wash with water (2 x 10 mL) and brine (10 mL).
- Dry the organic layer over anhydrous sodium sulfate, filter, and concentrate under reduced pressure.
- Purify the crude product by column chromatography on silica gel (eluent: hexane/ethyl acetate gradient) to obtain 4'-amino-[1,1'-biphenyl]-4-carbonitrile.

Quantitative Data:

Reactant/Product	Molar Ratio	Yield (%)	Reference
4-Bromoaniline	1.0	-	[1]
4-Cyanophenylboronic acid	1.2	-	[1]
4'-Amino-[1,1'-biphenyl]-4-carbonitrile	-	62	[1]

Protocol 2: Buchwald-Hartwig Amination for the Synthesis of N-Aryl Piperazines

This protocol provides a general methodology for the synthesis of N-aryl piperazines, a common scaffold in many pharmaceuticals, via the Buchwald-Hartwig amination of 4-bromoaniline with piperazine.

Reaction Scheme:

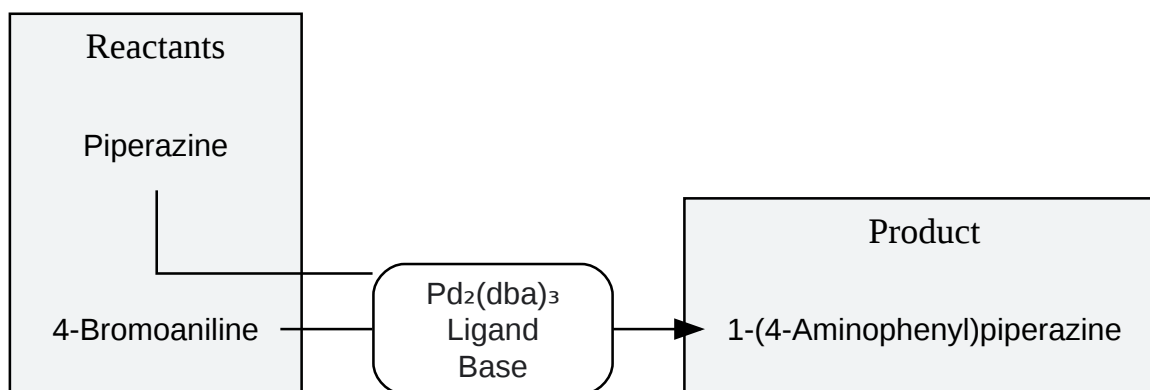

[Click to download full resolution via product page](#)

Caption: Buchwald-Hartwig amination of 4-bromoaniline.

Materials:

Reagent/Material	Molecular Weight (g/mol)
4-Bromoaniline	172.03
Piperazine	86.14
Tris(dibenzylideneacetone)dipalladium(0) (Pd ₂ (dba) ₃)	915.72
Xantphos	578.68
Sodium tert-butoxide (NaOtBu)	96.10
Toluene	92.14
Ethyl Acetate	88.11
Brine	-
Anhydrous Magnesium Sulfate	120.37

Experimental Procedure:

- In a flame-dried Schlenk flask under an inert atmosphere (e.g., argon), add 4-bromoaniline (1.0 mmol, 172 mg), piperazine (1.2 mmol, 103 mg), and sodium tert-butoxide (1.4 mmol, 135 mg).
- In a separate vial, prepare the catalyst system by adding Pd₂(dba)₃ (0.02 mmol, 18.3 mg) and Xantphos (0.04 mmol, 23.1 mg) to anhydrous toluene (2 mL).
- Add the catalyst solution to the Schlenk flask containing the reactants.
- Add an additional 8 mL of anhydrous toluene to the reaction mixture.
- Heat the reaction mixture to 100 °C and stir vigorously.
- Monitor the progress of the reaction by TLC or GC-MS.
- Upon completion (typically 8-12 hours), cool the reaction mixture to room temperature and dilute with ethyl acetate (20 mL).

- Wash the organic layer with water (2 x 10 mL) and brine (10 mL).
- Dry the organic layer over anhydrous magnesium sulfate, filter, and concentrate under reduced pressure.
- Purify the crude product by column chromatography on silica gel to yield the desired N-(4-aminophenyl)piperazine.

Quantitative Data (Representative):

Reactant/Product	Molar Ratio	Typical Yield (%)
4-Bromoaniline	1.0	-
Piperazine	1.2	-
N-(4-Aminophenyl)piperazine	-	80-95

Note: Yields are representative and can vary based on the specific substrate and reaction conditions.

Signaling Pathways and Experimental Workflows

The following diagrams illustrate the catalytic cycle of the Suzuki-Miyaura coupling and a general experimental workflow for cross-coupling reactions.

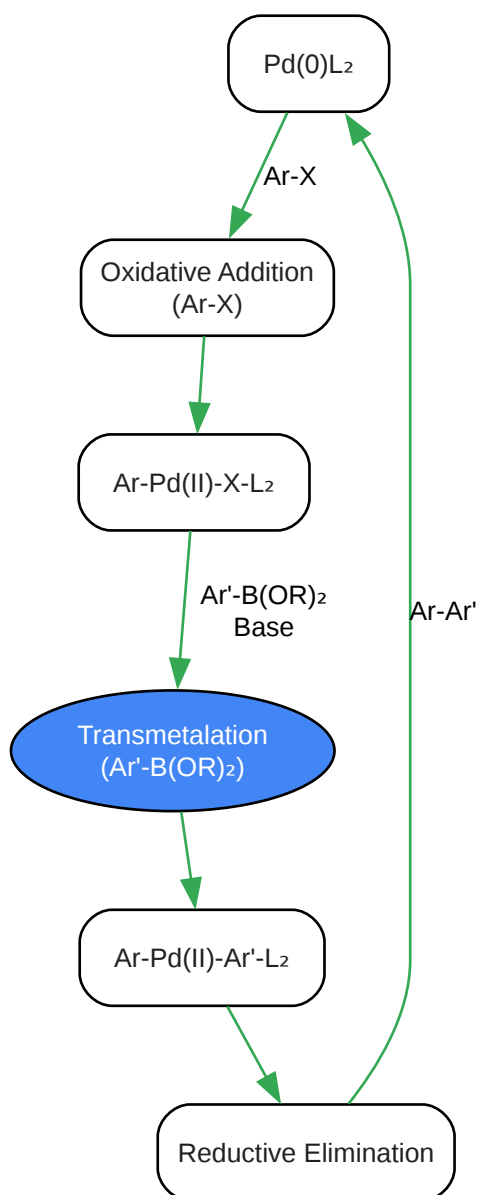

[Click to download full resolution via product page](#)

Caption: Catalytic cycle of the Suzuki-Miyaura coupling.

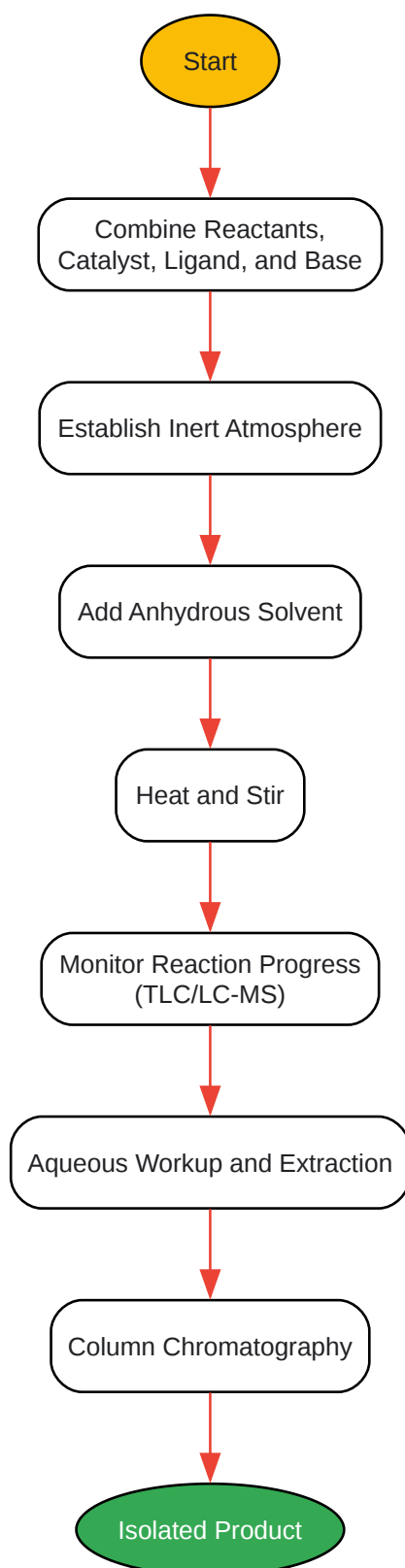

[Click to download full resolution via product page](#)

Caption: General experimental workflow for cross-coupling.

Conclusion

4-Bromoanilinium chloride is a highly valuable and versatile starting material for the synthesis of pharmaceutical intermediates. Its ability to undergo robust and reliable cross-coupling reactions, such as the Suzuki-Miyaura and Buchwald-Hartwig aminations, provides medicinal chemists with powerful tools for the construction of complex molecular scaffolds. The protocols and data presented herein offer a foundational guide for researchers and drug development professionals to effectively utilize this key building block in their synthetic campaigns.

Need Custom Synthesis?

BenchChem offers custom synthesis for rare earth carbides and specific isotopic labeling.

Email: info@benchchem.com or [Request Quote Online](#).

References

- [1. researchgate.net \[researchgate.net\]](#)
- [2. chemrxiv.org \[chemrxiv.org\]](#)
- [3. researchgate.net \[researchgate.net\]](#)
- [4. researchgate.net \[researchgate.net\]](#)
- [5. xingweili.snnu.edu.cn \[xingweili.snnu.edu.cn\]](#)
- [6. researchgate.net \[researchgate.net\]](#)
- To cite this document: BenchChem. [Application Notes and Protocols: 4-Bromoanilinium Chloride in Pharmaceutical Intermediate Synthesis]. BenchChem, [2026]. [Online PDF]. Available at: [<https://www.benchchem.com/product/b8028853/docs#application-notes-and-protocols-4-bromoanilinium-chloride-in-pharmaceutical-intermediate-synthesis>]

Disclaimer & Data Validity:

The information provided in this document is for Research Use Only (RUO) and is strictly not intended for diagnostic or therapeutic procedures. While BenchChem strives to provide accurate protocols, we make no warranties, express or implied, regarding the fitness of this product for every specific experimental setup.

Technical Support: The protocols provided are for reference purposes. Unsure if this reagent suits your experiment?

Need Industrial/Bulk Grade? [Request Custom Synthesis Quote](#)

BenchChem

Our mission is to be the trusted global source of essential and advanced chemicals, empowering scientists and researchers to drive progress in science and industry.

Contact

Address: 3281 E Guasti Rd
Ontario, CA 91761, United States
Phone: (601) 213-4426
Email: info@benchchem.com

[Contact our Ph.D. Support Team for a compatibility check](#)