

Validating Thiocyanate Incorporation using C NMR Spectroscopy

Author: BenchChem Technical Support Team. **Date:** May 2026

Compound of Interest

Compound Name: *4-Bromo-3-thiocyanato-benzoic acid ethyl ester*

Cat. No.: B8027765

[Get Quote](#)

Content Type: Publish Comparison Guide Audience: Researchers, scientists, and drug development professionals.

Executive Summary: The Isomer Challenge

In medicinal chemistry and heterocycle synthesis, the incorporation of a thiocyanate group (-SCN) is a pivotal step, often serving as a precursor for sulfur-containing scaffolds or as a pharmacophore itself.^[1] However, a critical synthetic liability exists: ambident reactivity. The thiocyanate anion can attack via sulfur (forming the desired thiocyanate, R-SCN) or nitrogen (forming the isothiocyanate, R-NCS). Furthermore, thermodynamic isomerization (the "allylic rearrangement") can convert kinetically favored thiocyanates into thermodynamically stable isothiocyanates during workup.

While Mass Spectrometry (MS) confirms the molecular weight and Infrared Spectroscopy (IR) identifies the cyano-stretch, neither offers the definitive structural resolution required for regulatory-grade characterization. This guide establishes

C NMR spectroscopy as the gold standard for validation, providing a self-validating protocol to distinguish these isomers with absolute certainty.

Comparative Analysis: Why C NMR Wins

The following table compares the three primary analytical techniques used for thiocyanate validation.

Feature	C NMR	FT-IR	Mass Spectrometry (HRMS)
Primary Output	Distinct Chemical Shift ()	Vibrational Frequency ()	Mass-to-Charge Ratio ()
Isomer Specificity	High (Distinct signals separated by >20 ppm)	Moderate (Overlapping regions)	Low (Identical mass)
Ambiguity Risk	Low. R-SCN and R-NCS occupy distinct spectral windows. ^[2]	High. Both stretch at 2000–2160 cm . Broadness varies but is subjective.	High. Requires complex fragmentation analysis to distinguish.
Quantification	Yes (with optimization).	Semi-quantitative at best.	No (ionization differences).
Sample State	Solution state (versatile).	Solid/Liquid/Gas.	Solution/Gas.

The "IR Trap"

Researchers often rely on IR because the -SCN stretch is strong. However, R-SCN typically absorbs at 2130–2175 cm

(sharp), while R-NCS absorbs at 2050–2200 cm

(broad, very strong). The overlap region (2130–2150 cm

) creates a "blind spot" where a mixture of isomers can be mistaken for a pure product.

Technical Deep Dive: The C NMR Validation Protocol

As a Senior Application Scientist, I recommend moving beyond "standard" automated NMR settings. The thiocyanate carbon is quaternary and lacks protons for efficient relaxation via dipolar coupling. Standard parameters often lead to signal saturation, resulting in a "missing peak" false negative.

A. Chemical Shift Fingerprinting

The definitive validation relies on the distinct electronic environments of the carbon atom in the two isomers.^[3]

- Thiocyanate ($-S-C\equiv N$): The carbon is shielded relative to the isothiocyanate.
 - Range: 108 – 115 ppm
 - Signal Character: Usually sharp, low intensity (quaternary).
- Isothiocyanate ($-N=C=S$): The carbon is deshielded and often affected by quadrupolar broadening from the adjacent

N nucleus.

- Range: 128 – 145 ppm
- Signal Character: Often broad or weak; can be "near-silent" in standard scans due to exchange dynamics.

B. Experimental Workflow (Self-Validating)

To ensure the absence of a signal is not an experimental artifact, follow this optimized protocol.

Step 1: Sample Preparation

- Concentration: High concentration is vital. Aim for >30 mg/0.6 mL solvent.
- Solvent: CDCl₃

is standard, but DMSO-

can prevent aggregation if the molecule is polar.

- Relaxation Agent (Optional but Recommended): For quantitative validation, add 1-2 mg of Cr(acac)

. This paramagnetic agent shortens the

relaxation time of the quaternary carbon, allowing for faster pulsing without saturation.

Step 2: Acquisition Parameters

Do not use the standard zg30 or zgpg30 blindly. Modify as follows:

- Pulse Sequence: Proton-decoupled

C (

C{

H}).

- Relaxation Delay (

):

- Standard: 1.0 – 2.0 sec (Insufficient for -SCN).

- Optimized: 3.0 – 5.0 sec. The quaternary carbon has a long longitudinal relaxation time (

). If you pulse too fast, the magnetization doesn't recover, and the signal disappears.

- Pulse Angle: Use 30° (approx. 3-4 μ s on many probes) rather than 90° to further mitigate saturation effects.
- Number of Scans (NS): Minimum 1024 scans. The signal-to-noise ratio (SNR) scales with the square root of scans. You are looking for a non-protonated carbon, which has no Nuclear Overhauser Effect (NOE) enhancement if inverse gated decoupling isn't used (or weak NOE otherwise).

Step 3: Processing & Analysis

- Exponential Multiplication (LB): Apply a Line Broadening of 1.0 - 3.0 Hz. This improves S/N at the cost of resolution (resolution is rarely an issue for these isolated peaks).
- Phasing: Manually phase the spectrum. Automated phasing often fails on small quaternary peaks.

Visualizing the Logic

Diagram 1: The Chemical Shift Decision Matrix

This diagram illustrates the spectral windows and the decision logic for assigning the structure.

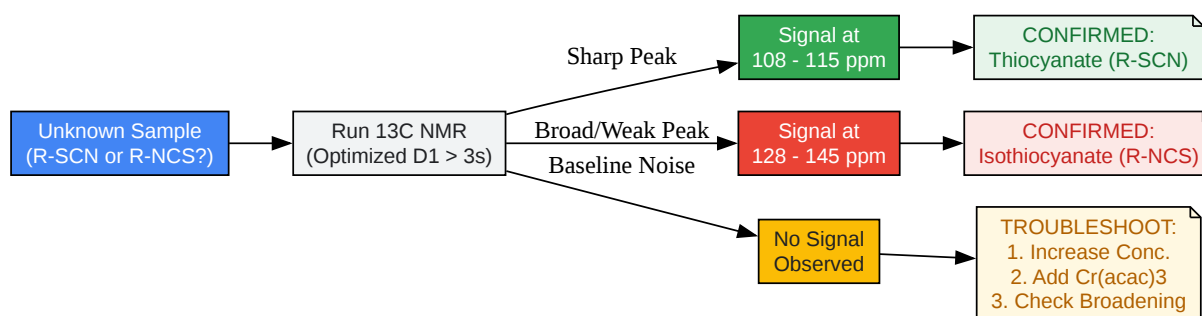

[Click to download full resolution via product page](#)

Caption: Decision matrix for distinguishing thiocyanate vs. isothiocyanate based on

C chemical shift regions.

Diagram 2: Experimental Workflow for Validation

This workflow ensures scientific rigor, preventing false negatives due to relaxation issues.

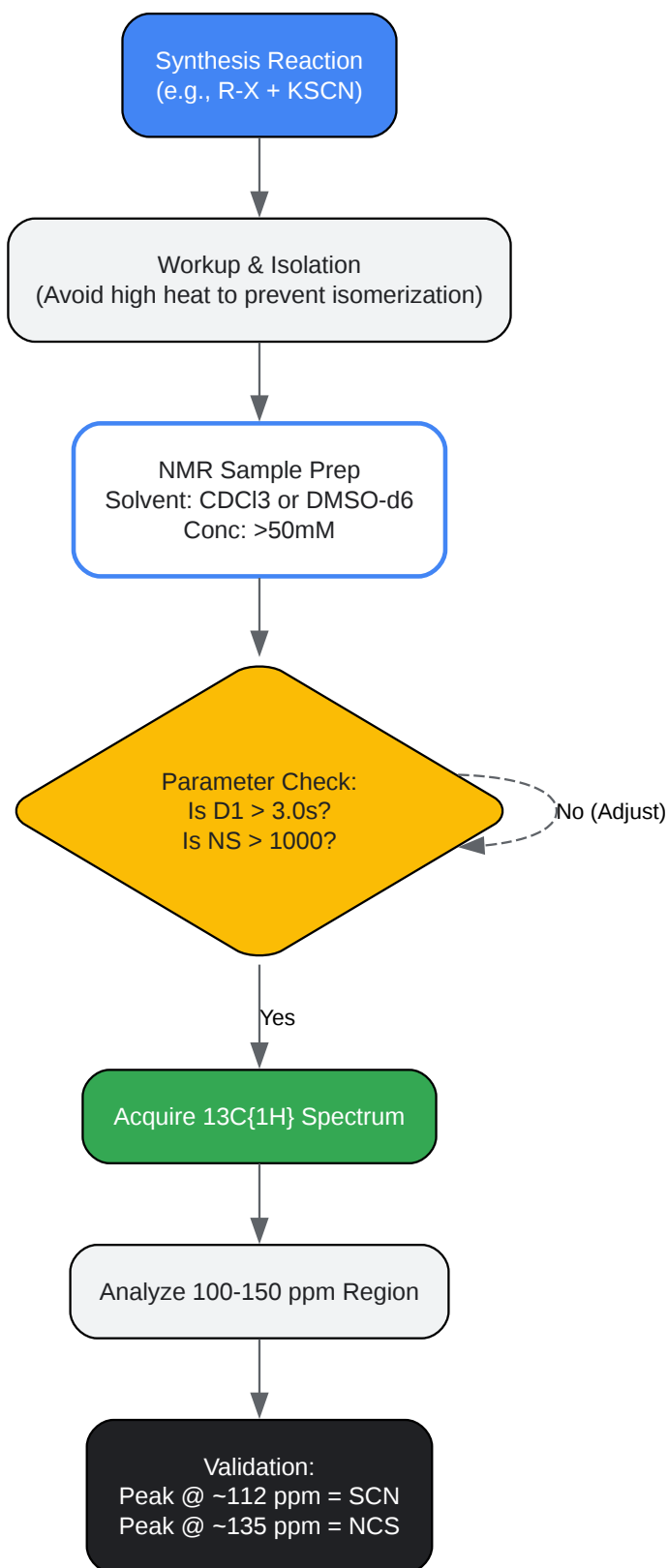

[Click to download full resolution via product page](#)

Caption: Step-by-step workflow emphasizing critical parameter checks (D1 delay) to ensure detection of quaternary carbons.

Troubleshooting & Expert Insights

The "Missing Peak" Phenomenon

Scenario: You synthesized a thiocyanate.^{[1][4]} Mass spec confirms the mass. IR shows a stretch at 2150 cm

. But the

¹³C NMR shows nothing in the 100–150 ppm range. Cause:

- Saturation: The relaxation delay () was too short (e.g., 1s). The quaternary carbon nuclei became saturated and ceased to give a signal.
- NCS Broadening: You actually made the isothiocyanate (NCS). The ¹³C signal for NCS is often extremely broad due to exchange dynamics and quadrupolar coupling to ¹⁴N, making it disappear into the baseline noise.

Solution:

- Re-run with .
- Look for a very broad "hump" around 130-140 ppm (indicative of NCS).
- If the peak at ~112 ppm appears sharp, it is SCN.

References

- RSC Publishing. "A comparative multinuclear ¹H, ¹³C, and ¹⁵N magnetic resonance study of organic thiocyanates and isothiocyanates."^[5] Journal of the Chemical Society, Perkin Transactions 2.^[5] [Link](#)

- National Institutes of Health (PubMed). "13C NMR of cyanylated flavodoxin... and of thiocyanate model compounds." Biochemistry. [Link](#)
- Oregon State University. "13C NMR Chemical Shift Ranges." Chemistry Department. [Link](#)
- Nanalysis. "Cheat codes for 13C qNMR: Handling Relaxation Times." [Link](#)
- ResearchGate. "Near-Silence of Isothiocyanate Carbon in 13C NMR Spectra: A Case Study." [Link](#)

Need Custom Synthesis?

BenchChem offers custom synthesis for rare earth carbides and specific isotopic labeling.

Email: info@benchchem.com or [Request Quote Online](#).

Sources

- [1. infoscience.epfl.ch](https://infoscience.epfl.ch) [infoscience.epfl.ch]
- [2. researchgate.net](https://researchgate.net) [researchgate.net]
- [3. chem.libretexts.org](https://chem.libretexts.org) [chem.libretexts.org]
- [4. Recent Advances in the Synthesis of Organic Thiocyanate \(SCN\) and Selenocyanate \(SeCN\) Compounds, Their Chemical Transformations and Bioactivity | MDPI](#) [mdpi.com]
- [5. A comparative multinuclear 1H, 13C, and 15N magnetic resonance study of organic thiocyanates and isothiocyanates - Journal of the Chemical Society, Perkin Transactions 2 \(RSC Publishing\)](#) [pubs.rsc.org]
- To cite this document: BenchChem. [Validating Thiocyanate Incorporation using C NMR Spectroscopy]. BenchChem, [2026]. [Online PDF]. Available at: [\[https://www.benchchem.com/product/b8027765/docs#validating-thiocyanate-incorporation-using-c-nmr-spectroscopy\]](https://www.benchchem.com/product/b8027765/docs#validating-thiocyanate-incorporation-using-c-nmr-spectroscopy)

Disclaimer & Data Validity:

The information provided in this document is for Research Use Only (RUO) and is strictly not intended for diagnostic or therapeutic procedures. While BenchChem strives to provide

accurate protocols, we make no warranties, express or implied, regarding the fitness of this product for every specific experimental setup.

Technical Support: The protocols provided are for reference purposes. Unsure if this reagent suits your experiment?

Need Industrial/Bulk Grade? [Request Custom Synthesis Quote](#)

BenchChem

Our mission is to be the trusted global source of essential and advanced chemicals, empowering scientists and researchers to drive progress in science and industry.

Contact

Address: 3281 E Guasti Rd

Ontario, CA 91761, United States

Phone: (601) 213-4426

Email: info@benchchem.com

[Contact our Ph.D. Support Team for a compatibility check](#)