

Technical Support Center: Boc-Val-Ala-OH Synthesis

Author: BenchChem Technical Support Team. **Date:** April 2026

Compound of Interest

Compound Name: *Boc-Val-Ala-OH*

Cat. No.: *B8020517*

[Get Quote](#)

This technical support center provides troubleshooting guidance for researchers, scientists, and drug development professionals experiencing incomplete coupling during the synthesis of **Boc-Val-Ala-OH**.

Frequently Asked Questions (FAQs)

Q1: What are the primary causes of incomplete **Boc-Val-Ala-OH** coupling?

Incomplete coupling of Boc-Val-OH to Ala-OH (or its ester derivative) is a common issue primarily due to the steric hindrance of the valine residue. Valine is a β -branched amino acid, which can make it difficult for the activated carboxylic acid of Boc-Val-OH to approach the amino group of alanine.[1] This steric hindrance slows down the reaction kinetics, often leading to incomplete reactions under standard coupling conditions.[1] Additionally, if the alanine residue is part of a larger peptide sequence, aggregation of the peptide can further prevent access to the reactive N-terminus.[1][2]

Q2: How can I detect an incomplete coupling reaction?

For solution-phase synthesis, the most common methods for monitoring reaction completion are Thin-Layer Chromatography (TLC) and High-Performance Liquid Chromatography (HPLC).

- **TLC:** By spotting the reaction mixture alongside the starting materials (Boc-Val-OH and the alanine derivative), you can visualize the consumption of starting materials and the formation of the product. An incomplete reaction will show a persistent spot for the limiting starting material.
- **HPLC & Mass Spectrometry (MS):** For a more definitive and quantitative analysis, a small aliquot of the crude reaction mixture can be analyzed by HPLC.^[1] The presence of significant amounts of starting materials in the chromatogram confirms an incomplete reaction.^[1] Mass spectrometry can be used to identify the peaks corresponding to starting materials and the desired product.

Q3: What immediate steps can I take if I detect an incomplete coupling?

If monitoring indicates an incomplete reaction, several strategies can be employed:

- **Extend the Reaction Time:** The simplest approach is to allow the reaction to proceed for a longer duration.
- **Increase Reagent Equivalents:** Adding a slight excess of the coupling agents and Boc-Val-OH can help drive the reaction to completion.^[1]
- **Switch to a More Powerful Coupling Reagent:** If using a standard carbodiimide like DCC or DIC, switching to a more potent uronium/aminium salt-based reagent such as HBTU, HATU, or HCTU is recommended for sterically hindered couplings.^{[1][3]}
- **Elevate the Temperature:** Gently increasing the reaction temperature (e.g., to 30-50°C) can improve the reaction rate, but should be done cautiously as it can also increase the risk of racemization.^{[1][4]}

Troubleshooting Guide

If you are experiencing low coupling efficiency for **Boc-Val-Ala-OH**, follow the troubleshooting workflow outlined below.

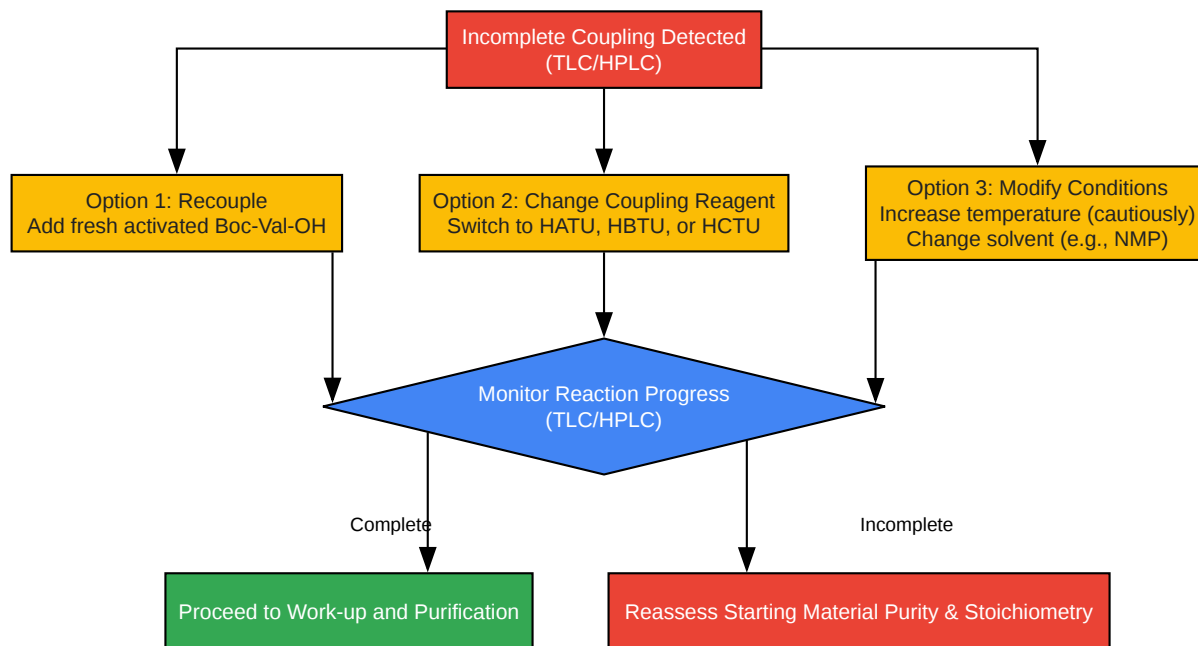

[Click to download full resolution via product page](#)

Caption: Troubleshooting workflow for incomplete **Boc-Val-Ala-OH** coupling.

Data Summary

The choice of coupling reagent significantly impacts the success of coupling sterically hindered amino acids. The following table summarizes the relative effectiveness of common coupling reagents.

Coupling Reagent Class	Examples	Relative Effectiveness for Hindered Couplings	Key Considerations
Carbodiimides	DCC, DIC	Moderate	Cost-effective; require an additive like HOBt or Oxyma to reduce racemization. The dicyclohexylurea (DCU) byproduct of DCC is insoluble, while the diisopropylurea from DIC is soluble.
Uronium/Aminium Salts	HBTU, HATU, HCTU	High	Generally more reactive and effective for difficult couplings. [1] Recommended for sterically hindered amino acids.[3]
Phosponium Salts	PyBOP, PyAOP	High	Also very effective for hindered couplings, rapidly forming highly reactive activated esters.[4]

Experimental Protocols

Protocol 1: DIC/Oxyma Mediated Coupling of Boc-Val-OH with L-Alanine Methyl Ester

This protocol is a cost-effective method with a good balance of efficiency and low racemization.

Materials:

- Boc-L-Valine (Boc-Val-OH)
- L-Alanine methyl ester hydrochloride (H-Ala-OMe·HCl)
- Diisopropylcarbodiimide (DIC)
- Ethyl cyanohydroxyiminoacetate (Oxyma)
- N,N-Diisopropylethylamine (DIEA)
- N,N-Dimethylformamide (DMF)
- Dichloromethane (DCM)
- Saturated aqueous sodium bicarbonate solution
- 1M aqueous hydrochloric acid solution
- Brine
- Anhydrous magnesium sulfate

Procedure:

- **Dissolution:** In a round-bottom flask, dissolve L-Alanine methyl ester hydrochloride (1.0 eq) in DMF. Add DIEA (1.1 eq) to neutralize the salt and stir for 10 minutes at room temperature.
- **Pre-activation:** In a separate vessel, dissolve Boc-L-Valine (1.1 eq) and Oxyma (1.2 eq) in DMF. Add DIC (1.2 eq) to this solution and stir at 0°C for 15-20 minutes.
- **Coupling:** Add the pre-activated Boc-L-Valine solution to the flask containing the neutralized alanine methyl ester.
- **Reaction:** Allow the reaction to warm to room temperature and stir for 4-12 hours.
- **Monitoring:** Monitor the reaction progress by TLC, eluting with an appropriate solvent system (e.g., ethyl acetate/hexanes). A complete reaction is indicated by the disappearance of the limiting starting material.

- Work-up:
 - Dilute the reaction mixture with ethyl acetate.
 - Wash the organic layer sequentially with 1M HCl, saturated NaHCO₃, and brine.
 - Dry the organic layer over anhydrous magnesium sulfate, filter, and concentrate under reduced pressure.
- Purification: Purify the crude product by flash column chromatography or recrystallization to obtain pure Boc-Val-Ala-OMe.

Protocol 2: HATU-Mediated Coupling

This protocol is recommended for difficult couplings involving sterically hindered amino acids.

[5]

Materials:

- Boc-L-Valine (Boc-Val-OH)
- L-Alanine methyl ester hydrochloride (H-Ala-OMe·HCl)
- HATU (1-[Bis(dimethylamino)methylene]-1H-1,2,3-triazolo[4,5-b]pyridinium 3-oxid hexafluorophosphate)
- N,N-Diisopropylethylamine (DIEA)
- N,N-Dimethylformamide (DMF)

Procedure:

- Dissolution: In a round-bottom flask, dissolve L-Alanine methyl ester hydrochloride (1.0 eq) and Boc-L-Valine (1.1 eq) in DMF.
- Activation: Add HATU (1.1 eq) to the solution. Cool the flask to 0°C in an ice bath.
- Base Addition: Slowly add DIEA (2.5 eq) to the reaction mixture.

- Reaction: Stir the mixture at 0°C for 15 minutes, then allow it to warm to room temperature and stir for 2-4 hours.
- Monitoring: Monitor the reaction completion by TLC or HPLC.
- Work-up and Purification: Follow the work-up and purification steps outlined in Protocol 1.

Signaling Pathways and Workflows

The following diagram illustrates the general chemical pathway for the coupling of Boc-Val-OH and an Alanine ester.

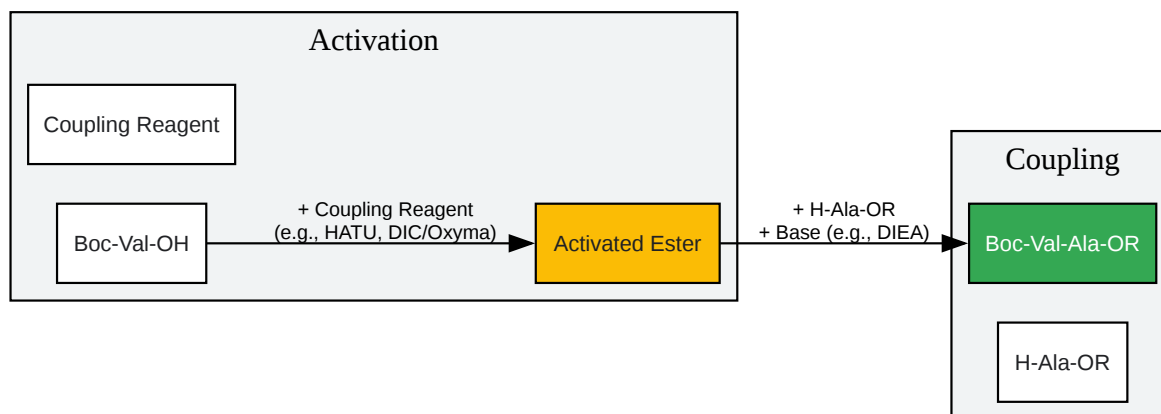

[Click to download full resolution via product page](#)

Caption: General pathway for **Boc-Val-Ala-OH** synthesis.

Need Custom Synthesis?

BenchChem offers custom synthesis for rare earth carbides and specific isotopic labeling.

Email: info@benchchem.com or [Request Quote Online](#).

References

1. [benchchem.com](https://www.benchchem.com) [[benchchem.com](https://www.benchchem.com)]

- [2. benchchem.com \[benchchem.com\]](#)
- [3. benchchem.com \[benchchem.com\]](#)
- [4. benchchem.com \[benchchem.com\]](#)
- [5. benchchem.com \[benchchem.com\]](#)
- To cite this document: BenchChem. [Technical Support Center: Boc-Val-Ala-OH Synthesis]. BenchChem, [2026]. [Online PDF]. Available at: [<https://www.benchchem.com/product/b8020517/docs#technical-support-center-boc-val-ala-oh-synthesis>]

Disclaimer & Data Validity:

The information provided in this document is for Research Use Only (RUO) and is strictly not intended for diagnostic or therapeutic procedures. While BenchChem strives to provide accurate protocols, we make no warranties, express or implied, regarding the fitness of this product for every specific experimental setup.

Technical Support: The protocols provided are for reference purposes. Unsure if this reagent suits your experiment?

Need Industrial/Bulk Grade? [Request Custom Synthesis Quote](#)

BenchChem

Our mission is to be the trusted global source of essential and advanced chemicals, empowering scientists and researchers to drive progress in science and industry.

Contact

Address: 3281 E Guasti Rd
Ontario, CA 91761, United States
Phone: (601) 213-4426
Email: info@benchchem.com

[Contact our Ph.D. Support Team for a compatibility check](#)

