

Technical Support Center: Thioanisole Acylation Optimization

Author: BenchChem Technical Support Team. **Date:** April 2026

Compound of Interest

Compound Name: 4-Oxo-4-(3-thiomethylphenyl)butyric acid
Cat. No.: B8001380

[Get Quote](#)

Executive Summary: The "Sulfur Problem"

Thioanisole (methyl phenyl sulfide) presents a unique paradox in Friedel-Crafts acylation. While the methylthio group (-SMe) is an activating group (ortho/para director) similar to the methoxy group in anisole, the sulfur atom is a "soft" Lewis base.

The Core Challenge: Traditional "hard" Lewis acids (like $AlCl_3$) coordinate strongly to the sulfur lone pair. This leads to two critical failure modes:

- **Catalyst Poisoning:** The catalyst is sequestered by the sulfur, requiring super-stoichiometric loading (>1.5 equiv) to drive the reaction.
- **Demethylation:** Strong Lewis acid coordination activates the S-Me bond for nucleophilic attack, cleaving the methyl group and yielding foul-smelling thiophenols instead of the desired ketone.

This guide provides optimization strategies to bypass these issues using modern catalysis (Metal Triflates) and shape-selective Zeolites, alongside optimized traditional protocols.

Catalyst Selection Matrix

The choice of catalyst dictates your impurity profile and workup difficulty.

Catalyst System	Type	Load (Equiv)	Pros	Cons	Best For
AlCl_3 / DCM	Hard Lewis Acid	1.2 – 2.0	High reactivity; Low cost; Well-established.	Demethylation risk; Generates stoichiometric waste; Moisture sensitive.	Small scale; Commodity synthesis where waste is managed.
$\text{Bi}(\text{OTf})_3$	Soft/Borderline	0.01 – 0.10	Water tolerant; Recyclable; Low toxicity; No demethylation.	Higher upfront cost; Slower kinetics than AlCl_3 .	Green chemistry; High-value API intermediates.
Zeolite H-Beta	Heterogeneous	10-20 wt%	Shape selective (High para selectivity); Reusable filterable solid.	Mass transfer limitations; Pore clogging (coking).	Scale-up; Continuous flow processes.
$\text{Sc}(\text{OTf})_3$	Hard (Lanthanide)	0.05 – 0.10	Extremely active; Recoverable.	Very expensive.	Complex substrates requiring mild conditions. ^[1]

Troubleshooting & Optimization Logic

Visualizing the Failure Modes

The following logic tree helps diagnose reaction failures based on experimental observations.

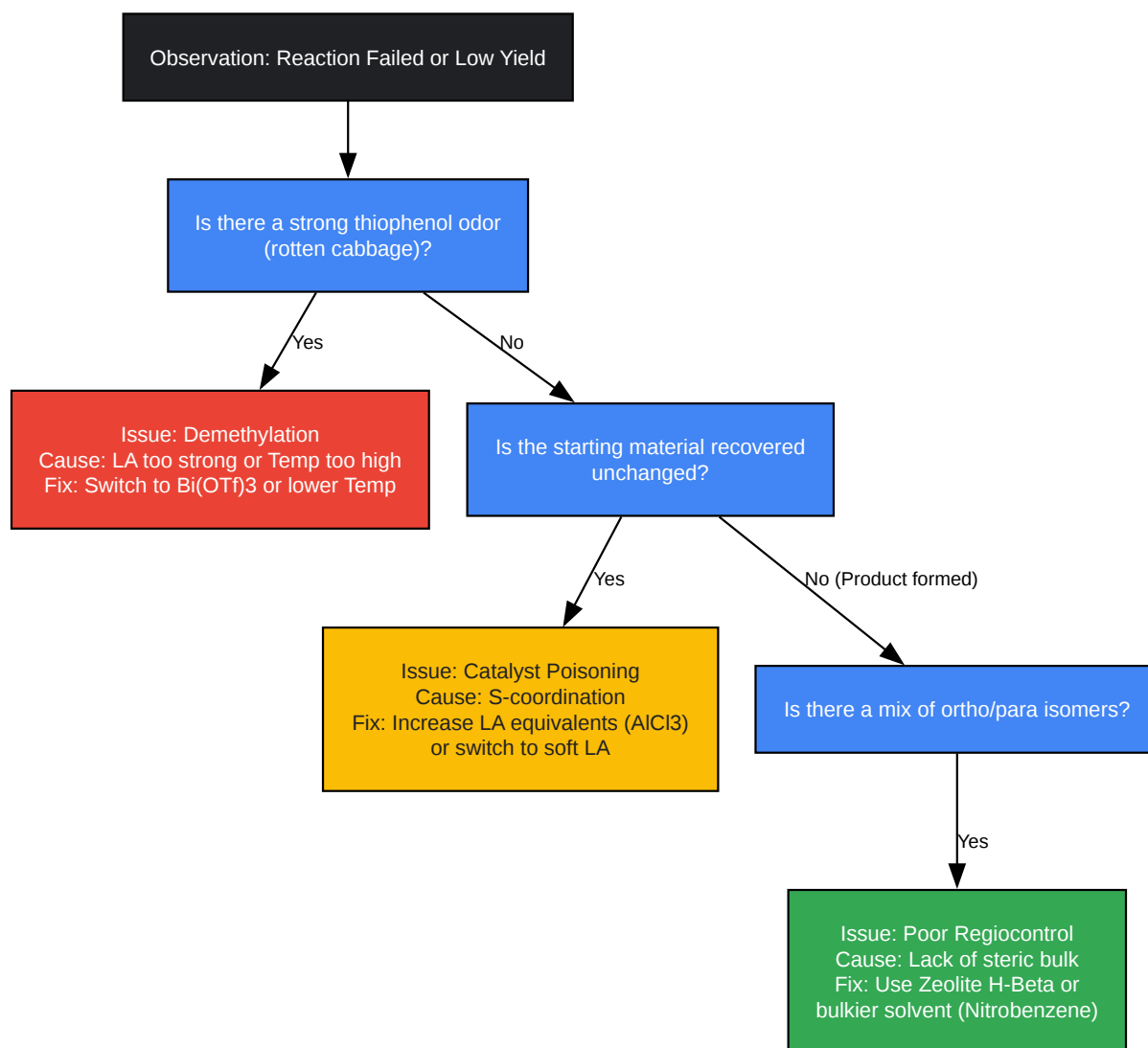

[Click to download full resolution via product page](#)

Caption: Diagnostic logic tree for isolating failure modes in thioanisole acylation.

Deep Dive: The Mechanism of Competition

To optimize, you must understand the competition between the Acylating Cycle and the Poisoning Cycle.

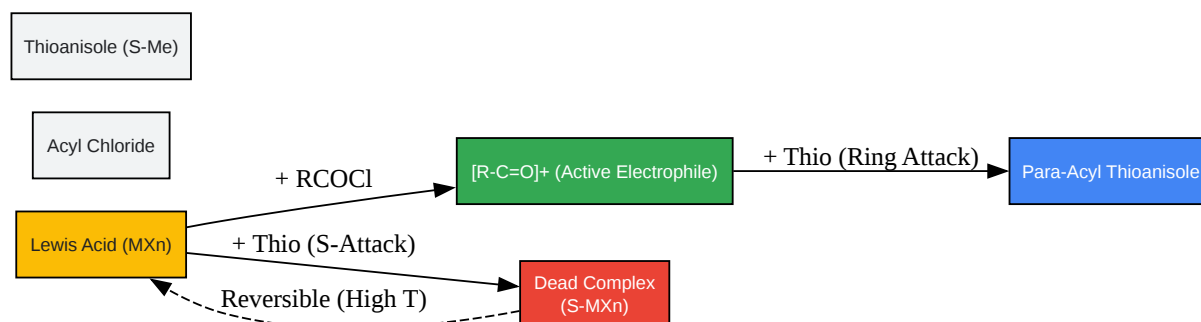

[Click to download full resolution via product page](#)

Caption: Kinetic competition between active acylium formation and catalyst poisoning by sulfur.

Recommended Protocols

Protocol A: The "Green" Method (Bismuth Triflate)

Recommended for high-value substrates where demethylation is unacceptable.

Rationale: Bismuth(III) is a "borderline" acid in HSAB theory. It activates the acyl chloride sufficiently but binds reversibly and weakly to the soft sulfur atom, preventing poisoning.

Materials:

- Thioanisole (1.0 equiv)[2]
- Acyl Chloride (1.2 equiv) or Acid Anhydride
- Bi(OTf)₃ (1 - 5 mol%)
- Solvent: Nitromethane (CH₃NO₂) or solvent-free.

Step-by-Step:

- Setup: Flame-dry a round-bottom flask under N_2 .
- Mixing: Add $Bi(OTf)_3$ (0.05 equiv) to the solvent.
- Addition: Add the acyl chloride followed by thioanisole at Room Temperature (RT).
- Reaction: Stir at RT. Note: If using anhydrides, heating to $50^\circ C$ may be required.
- Monitoring: Monitor by TLC. The reaction is usually slower than $AlCl_3$ (2–6 hours).
- Workup: Quench with water. Extract with EtOAc. The catalyst stays in the aqueous phase and can be concentrated/reused.

Protocol B: The "Shape Selective" Method (Zeolite H-Beta)

Recommended for maximizing para-selectivity.

Rationale: The pore structure of Zeolite Beta restricts the transition state for ortho substitution, forcing the reaction to the para position.

Materials:

- Thioanisole (10 mmol)
- Acetic Anhydride (15 mmol)
- Zeolite H-Beta (SiO_2/Al_2O_3 ratio ~25, calcined at $500^\circ C$ for 4h prior to use)
- Solvent: 1,2-Dichloroethane (DCE).

Step-by-Step:

- Activation: Ensure Zeolite is freshly calcined to remove adsorbed water.
- Reflux: Combine reactants and catalyst in DCE.

- Heat: Heat to reflux (80°C). Zeolites require higher energy than homogeneous catalysts due to diffusion limitations.
- Filtration: Once complete (GC/HPLC monitoring), filter the hot solution to remove the Zeolite.
- Isolation: Evaporate solvent. Recrystallize.

Frequently Asked Questions (FAQ)

Q: Why does my reaction smell like rotten cabbage? A: You have triggered demethylation. This occurs when using strong Lewis acids (AlCl_3 , BBr_3) at elevated temperatures. The Lewis acid coordinates to the sulfur, making the methyl group susceptible to nucleophilic attack (by Cl^-).

Fix: Lower the temperature or switch to a triflate catalyst ($\text{Bi}(\text{OTf})_3$).

Q: I used 1.0 equivalent of AlCl_3 but the yield is <50%. Why? A: In Friedel-Crafts acylation, the product (a ketone) is a Lewis base that complexes with the catalyst.^{[2][3]} This removes the catalyst from the cycle.^[2] Fix: You must use at least 1.1 to 1.2 equivalents of AlCl_3 relative to the acylating agent, not catalytic amounts.

Q: How do I remove the ortho isomer? A: The ortho isomer is difficult to separate by distillation due to similar boiling points. Fix: Use recrystallization (the para isomer is usually a solid, while ortho is liquid/oil). Alternatively, use Zeolite catalysts to prevent ortho formation initially.

References

- Friedel-Crafts Acylation with Metal Triflates: Desmurs, J. R., et al. "Bismuth(III) triflate: a safe and convenient catalyst for the Friedel–Crafts acylation reaction." *Tetrahedron Letters*, 1997.
- Zeolite Catalysis & Shape Selectivity: Smith, K., & El-Hiti, G. A. "Use of zeolites for greener and more para-selective electrophilic aromatic substitution reactions."^{[4][5]} *Green Chemistry*, 2011.^[4]
- Demethylation Mechanism: Node, M., et al. "Hard Acid and Soft Nucleophile Systems. New Efficient Method for Dealkylation of Esters and Ethers." *Journal of Organic Chemistry*, 1980.
- Bismuth Triflate Protocols: Repichet, S., et al. "Bismuth(III) Triflate: A Water-Stable and Recyclable Catalyst for the Friedel-Crafts Acylation." *Tetrahedron Letters*, 2002.

- General Friedel-Crafts Review: Olah, G. A. "Friedel-Crafts and Related Reactions." [1][2][3][6][7] Interscience Publishers, 1963. (Classic Reference for Stoichiometry).

Need Custom Synthesis?

BenchChem offers custom synthesis for rare earth carbides and specific isotopic labeling.

Email: info@benchchem.com or [Request Quote Online](#).

Sources

- 1. [semanticscholar.org](https://www.semanticscholar.org) [[semanticscholar.org](https://www.semanticscholar.org)]
- 2. pdf.benchchem.com [pdf.benchchem.com]
- 3. Friedel–Crafts reaction - Wikipedia [en.wikipedia.org]
- 4. Use of zeolites for greener and more para-selective electrophilic aromatic substitution reactions - Green Chemistry (RSC Publishing) [pubs.rsc.org]
- 5. [researchgate.net](https://www.researchgate.net) [[researchgate.net](https://www.researchgate.net)]
- 6. [researchgate.net](https://www.researchgate.net) [[researchgate.net](https://www.researchgate.net)]
- 7. [researchgate.net](https://www.researchgate.net) [[researchgate.net](https://www.researchgate.net)]
- To cite this document: BenchChem. [Technical Support Center: Thioanisole Acylation Optimization]. BenchChem, [2026]. [Online PDF]. Available at: [<https://www.benchchem.com/product/b8001380/docs#technical-support-center-thioanisole-acylation-optimization>]

Disclaimer & Data Validity:

The information provided in this document is for Research Use Only (RUO) and is strictly not intended for diagnostic or therapeutic procedures. While BenchChem strives to provide accurate protocols, we make no warranties, express or implied, regarding the fitness of this product for every specific experimental setup.

Technical Support: The protocols provided are for reference purposes. Unsure if this reagent suits your experiment?

Need Industrial/Bulk Grade? [Request Custom Synthesis Quote](#)

BenchChem

Our mission is to be the trusted global source of essential and advanced chemicals, empowering scientists and researchers to drive progress in science and industry.

Contact

Address: 3281 E Guasti Rd

Ontario, CA 91761, United States

Phone: (601) 213-4426

Email: info@benchchem.com

[Contact our Ph.D. Support Team for a compatibility check](#)