

Application Notes and Protocols for TiTe₂-Based Supercapacitors

Author: BenchChem Technical Support Team. **Date:** April 2026

Compound of Interest

Compound Name: Titanium telluride

CAS No.: 12067-75-3

Cat. No.: B080011

[Get Quote](#)

For Researchers, Scientists, and Drug Development Professionals

Introduction

Titanium ditelluride (TiTe₂), a member of the transition metal dichalcogenide (TMD) family, is an emerging material of interest for high-performance energy storage devices. Its unique layered structure, high electrical conductivity, and potential for fast ion intercalation make it a promising candidate for supercapacitor electrodes. These application notes provide a comprehensive overview of the development of TiTe₂-based supercapacitors, including detailed experimental protocols for material synthesis, electrode fabrication, and electrochemical characterization. Due to the limited availability of direct experimental literature on TiTe₂-based supercapacitors, the following protocols are adapted from established methods for similar transition metal tellurides and dichalcogenides, providing a robust starting point for research and development.

Transition metal tellurides (TMTes) have garnered significant interest for supercapacitors due to their high electrical conductivity, abundant redox-active sites, and excellent chemical stability. Among these, tellurides often exhibit higher conductivity compared to their sulfide and selenide counterparts, which is advantageous for high-performance supercapacitor applications.^[1]

Experimental Protocols

Synthesis of TiTe₂ Nanomaterials via Solvothermal Method

The solvothermal method is a versatile approach for synthesizing a variety of nanomaterials with controlled morphology and crystallinity. This protocol is adapted from procedures used for other transition metal chalcogenides.^{[2][3][4]}

Materials:

- Titanium (IV) isopropoxide (TTIP) or Titanium tetrachloride (TiCl₄) as the titanium precursor.
- Tellurium (Te) powder or Sodium tellurite (Na₂TeO₃) as the tellurium precursor.
- Ethanol or Ethylene glycol as the solvent.
- Hydrazine hydrate or Sodium borohydride (NaBH₄) as a reducing agent (if using Na₂TeO₃).
- Teflon-lined stainless-steel autoclave.

Procedure:

- Precursor Solution Preparation:
 - In a typical synthesis, dissolve a stoichiometric amount of the titanium precursor (e.g., 1 mmol of TTIP) in 20-40 mL of the chosen solvent (e.g., ethanol) under vigorous stirring.
 - In a separate container, dissolve the tellurium precursor (e.g., 2 mmol of Te powder) in the same solvent. If using a tellurium salt like Na₂TeO₃, a reducing agent such as hydrazine hydrate should be added to the tellurium precursor solution to reduce Te(IV) to Te(0).
- Mixing and Transfer:
 - Slowly add the tellurium precursor solution to the titanium precursor solution under continuous stirring to form a homogeneous mixture.
 - Transfer the resulting mixture into a Teflon-lined stainless-steel autoclave.

- Solvothermal Reaction:
 - Seal the autoclave and heat it in an oven to a temperature between 180°C and 220°C for 12 to 24 hours. The precise temperature and time will influence the crystallinity and morphology of the resulting TiTe₂ nanomaterials.

- Product Collection and Cleaning:
 - After the reaction, allow the autoclave to cool down to room temperature naturally.
 - Collect the black precipitate by centrifugation or filtration.
 - Wash the product multiple times with deionized water and ethanol to remove any unreacted precursors and byproducts.
 - Dry the final TiTe₂ product in a vacuum oven at 60°C for 12 hours.

Safety Precautions: Handle precursors and solvents in a well-ventilated fume hood. Autoclaves should be handled with care due to high pressures and temperatures.

Diagram of the Solvothermal Synthesis Workflow:

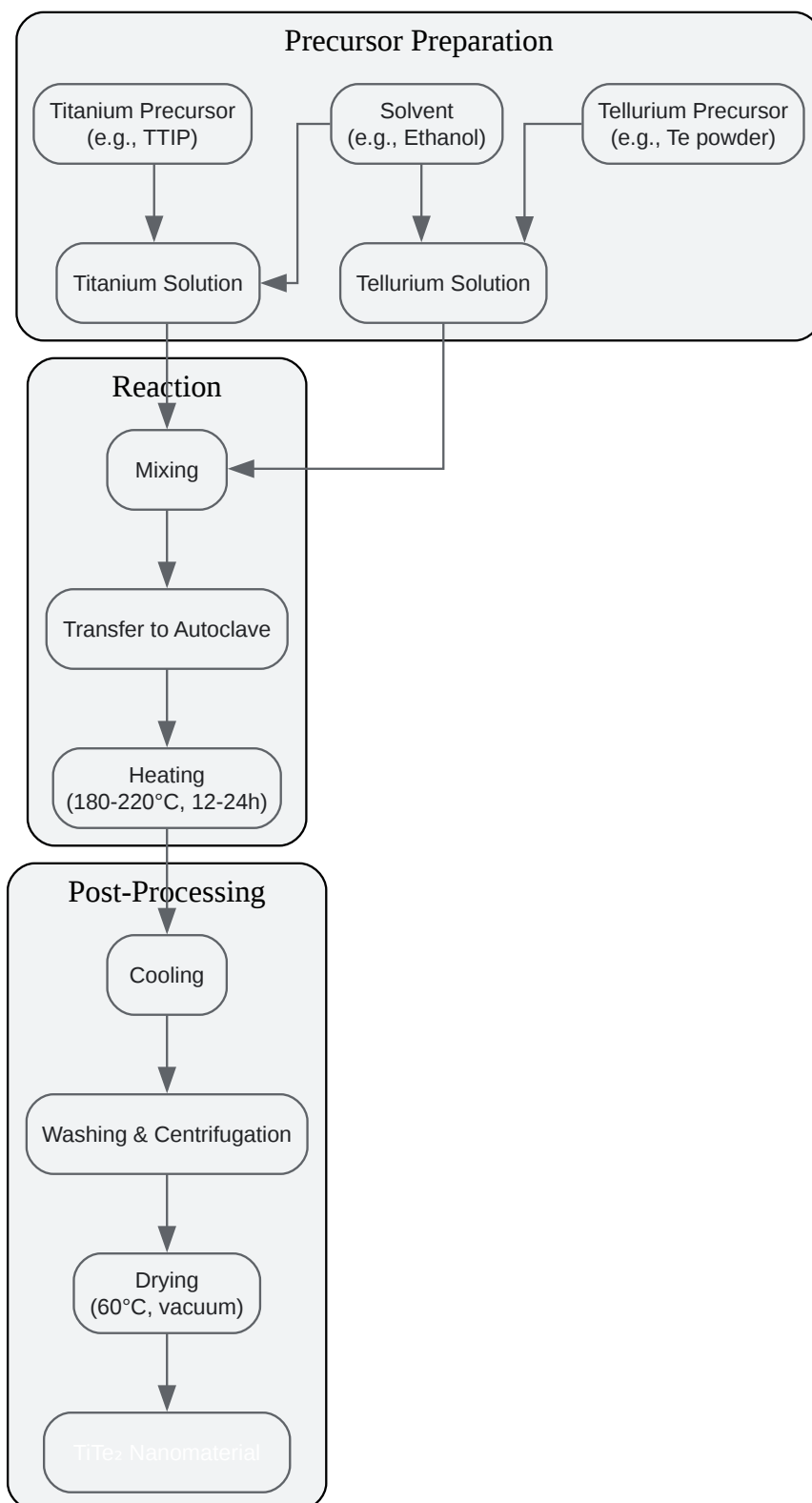

[Click to download full resolution via product page](#)

Solvothermal synthesis workflow for TiTe_2 nanomaterials.

Fabrication of TiTe₂-Based Supercapacitor Electrodes

This protocol outlines the standard slurry-casting method for preparing electrodes for supercapacitors.^{[5][6][7]}

Materials:

- Synthesized TiTe₂ nanomaterial (active material).
- Conductive additive (e.g., carbon black, Super P).
- Binder (e.g., polyvinylidene fluoride - PVDF).
- Solvent (e.g., N-methyl-2-pyrrolidone - NMP).
- Current collector (e.g., nickel foam, carbon cloth, or titanium foil).

Procedure:

- Slurry Preparation:
 - Prepare a homogeneous slurry by mixing the TiTe₂ active material, conductive additive, and binder in a typical weight ratio of 80:10:10.
 - Add a small amount of NMP solvent to the powder mixture and grind them together in a mortar or use a planetary ball mill for thorough mixing.
 - Continue adding NMP dropwise while mixing until a uniform, viscous slurry is formed. The consistency should be suitable for coating.
- Electrode Coating:
 - Clean the current collector by sonicating it in acetone, ethanol, and deionized water, and then dry it.
 - Coat the prepared slurry onto the cleaned current collector using a doctor blade or by drop-casting to ensure a uniform thickness.
- Drying and Pressing:

- Dry the coated electrode in a vacuum oven at 80-120°C for 12 hours to completely remove the solvent.
- After drying, press the electrode at a pressure of approximately 10 MPa to enhance the contact between the active material and the current collector.
- Mass Loading Determination:
 - Weigh the electrode before and after coating to determine the mass of the active material loaded onto the current collector.

Diagram of the Electrode Fabrication Workflow:

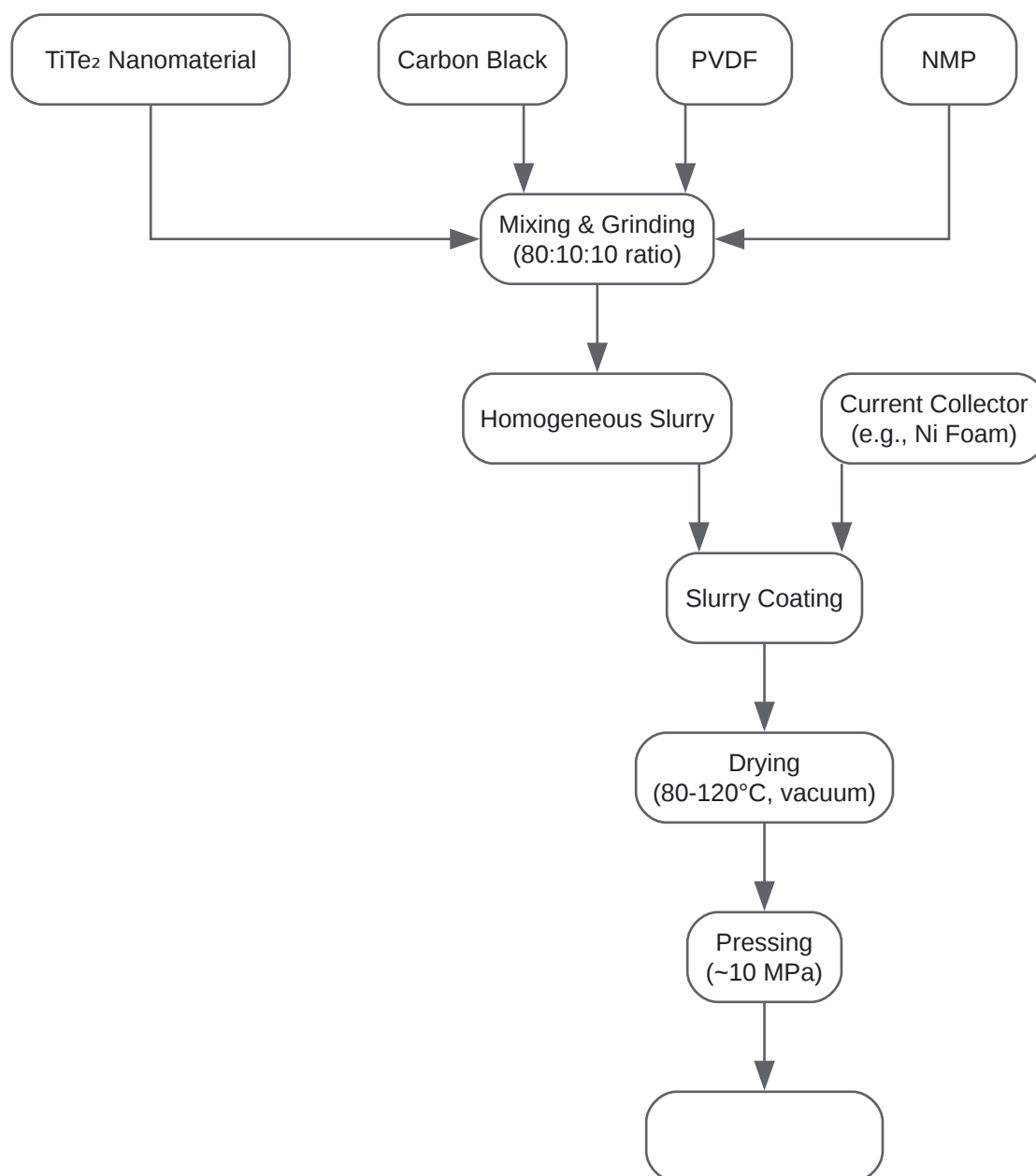

[Click to download full resolution via product page](#)

Workflow for the fabrication of TiTe₂-based supercapacitor electrodes.

Electrochemical Characterization

The electrochemical performance of the TiTe₂-based supercapacitors is evaluated using a three-electrode or a two-electrode (symmetric) setup.

Materials and Equipment:

- Fabricated TiTe₂ electrode (working electrode).
- Counter electrode (e.g., platinum wire or foil).
- Reference electrode (e.g., Ag/AgCl or Saturated Calomel Electrode - SCE).
- Electrolyte (e.g., aqueous solutions like 1 M KOH, 1 M Na₂SO₄, or organic electrolytes).
- Separator (for symmetric cell assembly, e.g., filter paper or Celgard).
- Electrochemical workstation (potentiostat/galvanostat).

Protocols:

- Cyclic Voltammetry (CV):
 - Purpose: To evaluate the capacitive behavior and determine the potential window of the electrode.
 - Procedure: Assemble the three-electrode cell with the TiTe₂ working electrode, counter electrode, and reference electrode in the chosen electrolyte. Sweep the potential within a defined window at various scan rates (e.g., 5, 10, 20, 50, 100 mV/s). The shape of the CV curve indicates the nature of charge storage (rectangular for electric double-layer capacitance, redox peaks for pseudocapacitance).
- Galvanostatic Charge-Discharge (GCD):
 - Purpose: To determine the specific capacitance, energy density, and power density.
 - Procedure: Charge and discharge the electrode at constant current densities (e.g., 0.5, 1, 2, 5, 10 A/g) within the potential window determined from the CV analysis. The specific capacitance can be calculated from the discharge curve using the formula: $C = (I * \Delta t) / (m * \Delta V)$, where I is the discharge current, Δt is the discharge time, m is the mass of the active material, and ΔV is the potential window.
- Electrochemical Impedance Spectroscopy (EIS):

- Purpose: To investigate the internal resistance, charge transfer resistance, and ion diffusion kinetics.
- Procedure: Apply a small AC voltage (e.g., 5-10 mV) over a wide frequency range (e.g., 100 kHz to 0.01 Hz). The resulting Nyquist plot provides information about the equivalent series resistance (ESR) and the charge transfer resistance (Rct).
- Cycling Stability:
 - Purpose: To evaluate the long-term performance and durability of the electrode.
 - Procedure: Subject the electrode to repeated GCD cycles at a high current density for a large number of cycles (e.g., 1,000 to 10,000 cycles). The capacitance retention is calculated as the ratio of the capacitance after cycling to the initial capacitance.

Diagram of the Electrochemical Characterization Workflow:

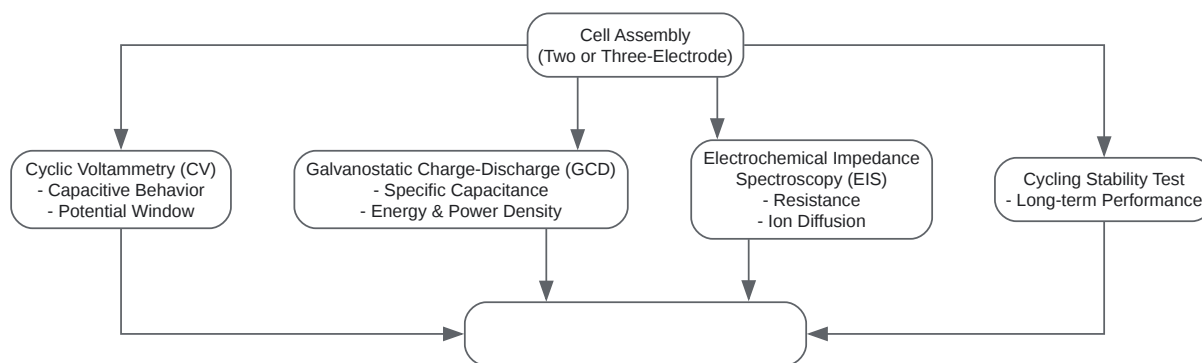

[Click to download full resolution via product page](#)

Workflow for electrochemical characterization of TiTe₂-based supercapacitors.

Data Presentation

Quantitative data from electrochemical characterization should be summarized in tables for clear comparison. Below is a template table for presenting the performance metrics of TiTe₂-

based supercapacitors, with example data ranges derived from studies on other transition metal tellurides.[8][9]

Material	Electrolyte	Specific Capacitance (F/g) @ Current Density (A/g)	Energy Density (Wh/kg)	Power Density (W/kg)	Cycling Stability (% retention after cycles)	Reference
TiTe ₂ (Hypothetical)	1 M KOH	e.g., 400-800 @ 1	e.g., 20-40	e.g., 500-2000	e.g., >90% after 5000	This work
CoTe Nanorods	3.5 M KOH	370 C/g @ 1 A/g	40.7	22,500	~90.5% after 5000	[9]
NiTe Nanorods	3.5 M KOH	370 C/g @ 1 A/g	-	-	Good	[9]
FeTe:Fe ₂ T eO ₅ /MWC NTs	-	773.69 @ 3 mV/s	8.19	108	95% after 5000	[8]

Conclusion

While the field of TiTe₂-based supercapacitors is still in its nascent stages, the protocols and data presented here, adapted from closely related materials, provide a strong foundation for researchers to explore the potential of this promising material. The unique properties of transition metal tellurides suggest that TiTe₂ could offer significant advantages in terms of conductivity and charge storage capacity. Further research is necessary to optimize synthesis parameters, electrode architecture, and electrolyte selection to fully realize the potential of TiTe₂ for next-generation energy storage applications.

Need Custom Synthesis?

BenchChem offers custom synthesis for rare earth carbides and specific isotopic labeling.

Email: info@benchchem.com or [Request Quote Online](#).

References

- [1. researchgate.net \[researchgate.net\]](#)
- [2. researchgate.net \[researchgate.net\]](#)
- [3. Investigation into the thermodynamics and kinetics of the binding of Cu²⁺ and Pb²⁺ to TiS₂ nanoparticles synthesized using a solvothermal process - PubMed \[pubmed.ncbi.nlm.nih.gov\]](#)
- [4. iosrjournals.org \[iosrjournals.org\]](#)
- [5. mtixtl.com \[mtixtl.com\]](#)
- [6. US10693122B2 - Method for preparing electrode slurry - Google Patents \[patents.google.com\]](#)
- [7. substack.exponentialindustry.com \[substack.exponentialindustry.com\]](#)
- [8. researchgate.net \[researchgate.net\]](#)
- [9. pubs.rsc.org \[pubs.rsc.org\]](#)
- To cite this document: BenchChem. [Application Notes and Protocols for TiTe₂-Based Supercapacitors]. BenchChem, [2026]. [Online PDF]. Available at: [\[https://www.benchchem.com/product/b080011/docs#application-notes-and-protocols-for-tite-based-supercapacitors\]](https://www.benchchem.com/product/b080011/docs#application-notes-and-protocols-for-tite-based-supercapacitors)

Disclaimer & Data Validity:

The information provided in this document is for Research Use Only (RUO) and is strictly not intended for diagnostic or therapeutic procedures. While BenchChem strives to provide accurate protocols, we make no warranties, express or implied, regarding the fitness of this product for every specific experimental setup.

Technical Support: The protocols provided are for reference purposes. Unsure if this reagent suits your experiment?

Need Industrial/Bulk Grade? [Request Custom Synthesis Quote](#)

BenchChem

Our mission is to be the trusted global source of essential and advanced chemicals, empowering scientists and researchers to drive progress in science and industry.

Contact

Address: 3281 E Guasti Rd

Ontario, CA 91761, United States

Phone: (601) 213-4426

Email: info@benchchem.com

[Contact our Ph.D. Support Team for a compatibility check](#)