

Application Note: Analysis of Tetratriacontane by Gas Chromatography-Mass Spectrometry (GC-MS)

Author: BenchChem Technical Support Team. **Date:** December 2025

Compound of Interest

Compound Name: Tetratriacontane

Cat. No.: B080029

[Get Quote](#)

Introduction

Tetratriacontane (C₃₄H₇₀) is a long-chain saturated hydrocarbon belonging to the n-alkane series. It is found in various natural sources, including plant waxes and geological samples. The analysis of **tetratriacontane** is crucial in diverse fields such as environmental science for crude oil contamination assessment, geochemistry for biomarker studies, and in the chemical industry for quality control of waxes and paraffins. Gas Chromatography-Mass Spectrometry (GC-MS) is a highly effective analytical technique for the identification and quantification of **tetratriacontane** due to its ability to separate volatile and semi-volatile compounds and provide detailed molecular information for their identification.^{[1][2][3]} This application note outlines a comprehensive method for the analysis of **tetratriacontane** using GC-MS.

Experimental Protocols

Sample and Standard Preparation

Proper sample preparation is essential for accurate GC-MS analysis. The primary objective is to dissolve the analyte in a suitable volatile organic solvent and eliminate any particulate matter that could interfere with the analysis.^{[1][4]}

- **Solvent Selection:** High-purity volatile organic solvents such as hexane, dichloromethane, or iso-octane are recommended. It is crucial to avoid water and other non-volatile solvents.

- Standard Solution Preparation (1 mg/mL):
 - Accurately weigh 10 mg of pure **tetratriacontane** standard.
 - Transfer the standard into a 10 mL volumetric flask.
 - Add the selected solvent (e.g., hexane) to dissolve the standard completely.
 - Fill the flask to the 10 mL mark with the solvent and mix thoroughly.
- Working Standard Preparation (10 µg/mL):
 - Pipette 100 µL of the 1 mg/mL stock solution into a 10 mL volumetric flask.
 - Dilute to the mark with the solvent and mix. This concentration is suitable for achieving a column loading of approximately 10 ng with a 1 µL injection.
- Sample Preparation: For solid samples, dissolve a known quantity in a suitable solvent to achieve a final concentration within the instrument's calibration range. If the sample contains particulate matter, it should be filtered through a 0.22 µm syringe filter to prevent contamination of the GC inlet and column.

GC-MS Instrumentation and Parameters

The following instrumental parameters are recommended for the analysis of **tetratriacontane**. These may be optimized based on the specific instrument and analytical requirements.

Table 1: GC-MS Instrumental Parameters

Parameter	Value	Rationale
Gas Chromatograph	Agilent 6890N or similar	Widely used and reliable platform.
Mass Spectrometer	Agilent 5973N or similar	Provides good sensitivity and spectral data.
GC Column	DB-1ms (or equivalent 100% Dimethylpolysiloxane), 60 m x 0.25 mm ID, 0.25 µm film thickness	A non-polar stationary phase provides good selectivity for non-polar alkanes. A longer column enhances resolution.
Carrier Gas	Helium or Hydrogen	Inert and provides good chromatographic efficiency. Hydrogen can allow for faster analysis.
Carrier Gas Flow	1.0 - 2.0 mL/min (Constant Flow Mode)	Optimal flow rate for good separation.
Injection Mode	Splitless	To maximize the transfer of analytes to the column for trace analysis.
Injection Volume	1 µL	A standard volume to avoid column overloading.
Inlet Temperature	300°C	Ensures complete vaporization of the high-boiling point analyte.
Oven Program	Initial: 80°C, hold for 2 min. Ramp 1: 10°C/min to 200°C. Ramp 2: 5°C/min to 320°C, hold for 10 minutes.	A slower ramp rate in the higher temperature range improves the separation of long-chain alkanes.
Transfer Line Temp.	300°C	Prevents condensation of the analyte before entering the mass spectrometer.

Ion Source Temp.	230°C	Standard temperature for electron ionization.
Ionization Mode	Electron Ionization (EI) at 70 eV	Standard ionization energy that provides reproducible fragmentation patterns.
Mass Scan Range	m/z 40-600	Covers the expected molecular ion and fragment ions of tetratriacontane.
Solvent Delay	5 minutes	To prevent the solvent peak from saturating the detector.

Data Presentation

The mass spectrum of **tetratriacontane** is characterized by a series of fragment ions resulting from the cleavage of C-C bonds. This leads to clusters of peaks separated by 14 mass units (CH₂). The molecular ion peak (M⁺) at m/z 478.9 is often of low abundance or absent.

Table 2: Characteristic Mass Fragments of **Tetratriacontane**

m/z	Ion Formula	Relative Intensity
57	[C ₄ H ₉] ⁺	High
71	[C ₅ H ₁₁] ⁺	High
85	[C ₆ H ₁₃] ⁺	Moderate
99	[C ₇ H ₁₅] ⁺	Moderate
113	[C ₈ H ₁₇] ⁺	Moderate
478.9	[C ₃₄ H ₇₀] ⁺	Very Low to Absent

Note: Relative intensities are general and can vary slightly between instruments.

Visualized Workflow

The following diagram illustrates the experimental workflow for the GC-MS analysis of **Tetratriacontane**.

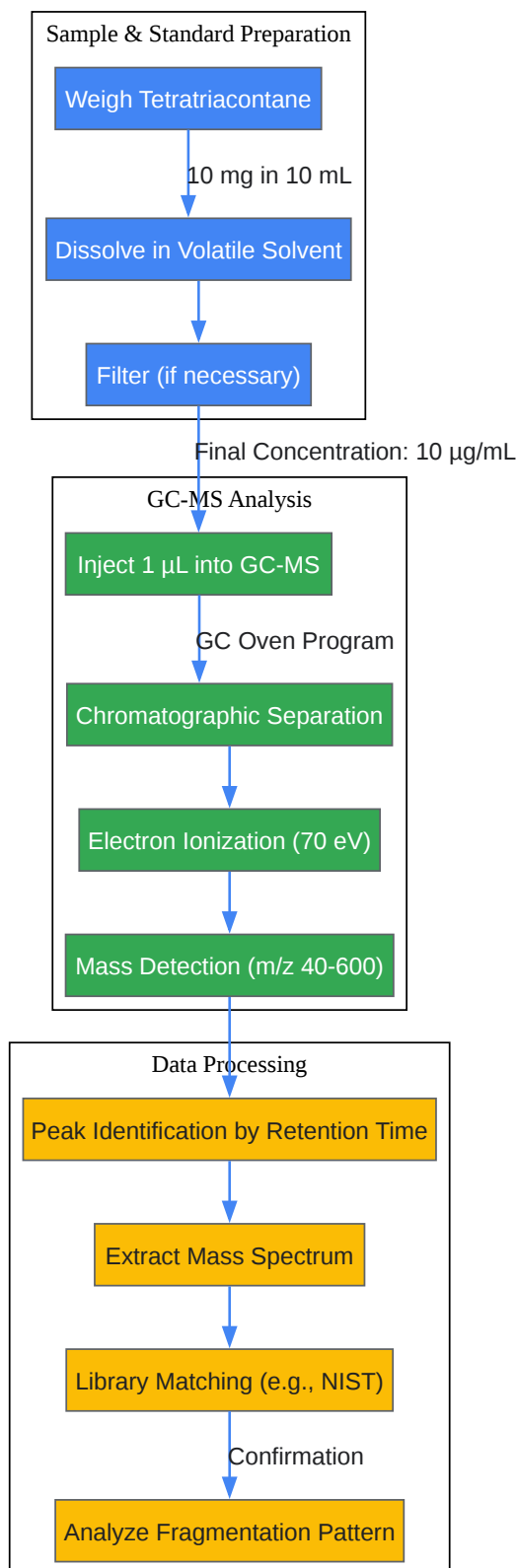

[Click to download full resolution via product page](#)

Need Custom Synthesis?

BenchChem offers custom synthesis for rare earth carbides and specific isotopic labeling.

Email: info@benchchem.com or [Request Quote Online](#).

References

- 1. Sample preparation GC-MS [scioninstruments.com]
- 2. benchchem.com [benchchem.com]
- 3. benchchem.com [benchchem.com]
- 4. Common Sample Preparation Techniques for GC-MS Analysis [hplcvials.com]
- To cite this document: BenchChem. [Application Note: Analysis of Tetratriacontane by Gas Chromatography-Mass Spectrometry (GC-MS)]. BenchChem, [2025]. [Online PDF]. Available at: [<https://www.benchchem.com/product/b080029#gas-chromatography-mass-spectrometry-gc-ms-analysis-of-tetratriacontane>]

Disclaimer & Data Validity:

The information provided in this document is for Research Use Only (RUO) and is strictly not intended for diagnostic or therapeutic procedures. While BenchChem strives to provide accurate protocols, we make no warranties, express or implied, regarding the fitness of this product for every specific experimental setup.

Technical Support: The protocols provided are for reference purposes. Unsure if this reagent suits your experiment? [[Contact our Ph.D. Support Team for a compatibility check](#)]

Need Industrial/Bulk Grade? [Request Custom Synthesis Quote](#)

BenchChem

Our mission is to be the trusted global source of essential and advanced chemicals, empowering scientists and researchers to drive progress in science and industry.

Contact

Address: 3281 E Guasti Rd

Ontario, CA 91761, United States

Phone: (601) 213-4426

Email: info@benchchem.com