

# A Comprehensive Technical Guide to Aluminum Monochloride

**Author:** BenchChem Technical Support Team. **Date:** May 2026

## Compound of Interest

Compound Name: Aluminum monochloride

CAS No.: 13595-81-8

Cat. No.: B080767

[Get Quote](#)

For Researchers, Scientists, and Drug Development Professionals

## Introduction

**Aluminum monochloride** (AlCl) is a diatomic molecule that has garnered significant interest in fields ranging from astrophysics to materials science. Unlike the more common aluminum trichloride (AlCl<sub>3</sub>), AlCl is a thermodynamically stable species only at high temperatures and low pressures.<sup>[1]</sup> Its highly reactive nature makes it a transient intermediate in various chemical processes, most notably in the Alcan process for aluminum smelting. This guide provides an in-depth overview of the chemical and physical properties, synthesis, and experimental characterization of **aluminum monochloride**, with a focus on the technical details relevant to researchers in the physical sciences. While direct applications in drug development are not established due to its instability under physiological conditions, this document provides a foundational understanding of this simple but important metal halide.

## Chemical and Physical Properties

**Aluminum monochloride** is a radical species with a single unpaired electron. Its electronic structure and bonding have been the subject of numerous spectroscopic and computational

studies.

Table 1: General Properties of **Aluminum Monochloride**

Property	Value	Reference
Chemical Formula	AlCl	[1]
Molecular Weight	62.435 g/mol	
IUPAC Name	Chloridoaluminum	
State at STP	Gas (unstable)	[1]
Electronic Ground State	$X^1\Sigma^+$	[2]

Table 2: Spectroscopic Constants of **Aluminum Monochloride** ( $X^1\Sigma^+$  ground state)

Constant	Value	Technique	Reference
$B_e$	7312.74 Mc/sec	Microwave Spectroscopy	[3]
$\alpha_e$	48.03 Mc/sec	Microwave Spectroscopy	[3]
$r_e$	2.12983 Å	Microwave Spectroscopy	[3]
$\omega_e$	481.7747 $\text{cm}^{-1}$	Absorption Spectroscopy	
$\omega_e X_e$	2.101811 $\text{cm}^{-1}$	Absorption Spectroscopy	
$(eqQ)_{a1}(\text{Al})$	-29.2 Mc/sec	Microwave Spectroscopy	[3]
$(eqQ)_{a1}({}^{35}\text{Cl})$	-8.8 Mc/sec	Microwave Spectroscopy	[3]

Table 3: Thermodynamic Properties of Gaseous **Aluminum Monochloride**

Property	Value	Reference
Standard Enthalpy of Formation ( $\Delta_f H^\circ_{\text{gas}}$ )	-584.59 kJ/mol	[4]
Standard Molar Entropy ( $S^\circ_{\text{gas}}$ )	314.44 J/(mol K)	[4]
Heat Capacity (cp)	82.46 J/(mol K)	[4]

## Synthesis and Generation

Due to its high reactivity and instability under standard conditions, **aluminum monochloride** is typically generated in situ for experimental studies. There are no standard laboratory procedures for the synthesis and isolation of bulk AlCl.

## High-Temperature Reaction

The primary industrial context for AlCl formation is the Alcan process, where aluminum-rich alloys are heated to approximately 1,300 °C in the presence of aluminum trichloride to produce gaseous AlCl. This is then disproportionated upon cooling to yield pure aluminum.

The overall reaction is:  $2 \text{Al}(\text{alloy}) + \text{AlCl}_3(\text{gas}) \rightleftharpoons 3 \text{AlCl}(\text{gas})$

A laboratory-scale method for generating gaseous AlCl involves the high-temperature reaction of aluminum metal with a chlorine source.

### Experimental Protocol: High-Temperature Generation of AlCl for Spectroscopy

- Apparatus: A high-temperature furnace equipped with a quartz or alumina reaction tube. A vacuum system is required to maintain low pressure. The reaction products are then passed into a spectrometer.
- Procedure:
  - Place aluminum metal turnings or powder in the center of the reaction tube.

- Evacuate the system to a low pressure.
- Heat the furnace to a temperature between 650 and 750 °C.[5][6]
- Introduce a controlled flow of chlorine gas (Cl<sub>2</sub>) or hydrogen chloride (HCl) gas over the heated aluminum.[5][6]
- The resulting gaseous AlCl can be directly analyzed by a suitable spectroscopic technique.

## Laser Ablation

A common and effective method for producing a beam of cold AlCl molecules for high-resolution spectroscopy is laser ablation.

### Experimental Protocol: Generation of AlCl via Laser Ablation

- Apparatus: A cryogenic helium buffer-gas beam source, a high-power pulsed laser (e.g., Nd:YAG), and a solid precursor target.
- Procedure:
  - Prepare a solid precursor target, which can be a mixture of aluminum powder and a chlorine donor like potassium chloride (KCl).[7]
  - Place the target in a vacuum chamber equipped with a cryogenic buffer-gas cell.
  - Introduce helium buffer gas into the cell and cool it to cryogenic temperatures (e.g., 4 K).
  - Ablate the surface of the precursor target with short pulses from a high-power laser (e.g., 532 nm).[7]
  - The ablated material thermalizes with the cold helium gas, forming a beam of cold AlCl molecules that can be interrogated by spectroscopic methods downstream.[7]

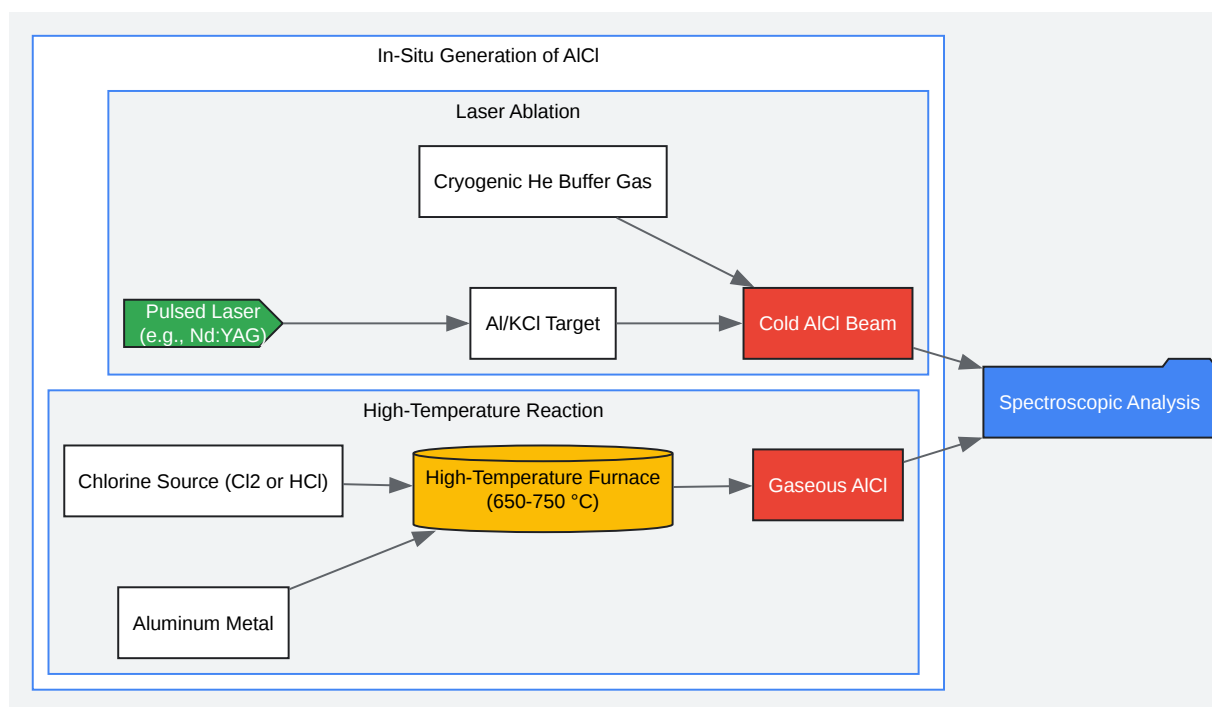

[Click to download full resolution via product page](#)

Methods for the in-situ generation of **aluminum monochloride**.

## Spectroscopic Characterization

The transient nature of AlCl<sub>3</sub> necessitates the use of various spectroscopic techniques for its characterization.

## Microwave Spectroscopy

Microwave spectroscopy provides highly precise information about the rotational energy levels of molecules, from which accurate molecular geometries and electronic properties can be derived.

Experimental Protocol: High-Temperature Microwave Spectroscopy of AlCl<sub>3</sub>

- Apparatus: A high-temperature microwave spectrometer consisting of a microwave source, an absorption cell capable of being heated to high temperatures, and a detector.
- Procedure:
  - Generate gaseous AlCl within the high-temperature absorption cell using the high-temperature reaction method described previously.
  - Pass microwaves through the cell and measure the absorption as a function of frequency.
  - The observed transitions correspond to changes in the rotational quantum number, J.
  - Analysis of the rotational spectrum yields the rotational constant (B), the centrifugal distortion constant (D), and nuclear quadrupole coupling constants (eQq).[3][8]

## Infrared Spectroscopy

Infrared (IR) spectroscopy probes the vibrational energy levels of molecules. For a diatomic molecule like AlCl, there is one fundamental vibrational mode.

### Experimental Protocol: Matrix Isolation Infrared Spectroscopy of AlCl

Matrix isolation is a technique used to trap reactive species in an inert solid matrix at low temperatures, allowing for their spectroscopic study.

- Apparatus: A cryostat with a cold window (e.g., CsI cooled to ~4 K), a deposition system for the sample and matrix gas, and an FTIR spectrometer.
- Procedure:
  - Generate gaseous AlCl using one of the methods described above.
  - Co-deposit the gaseous AlCl with a large excess of an inert matrix gas (e.g., argon) onto the cold window.[9]
  - The AlCl molecules are trapped in the solid argon matrix, preventing them from reacting with each other.

- Record the infrared spectrum of the matrix-isolated sample. The vibrational frequency of AlCl can be determined from the absorption bands.

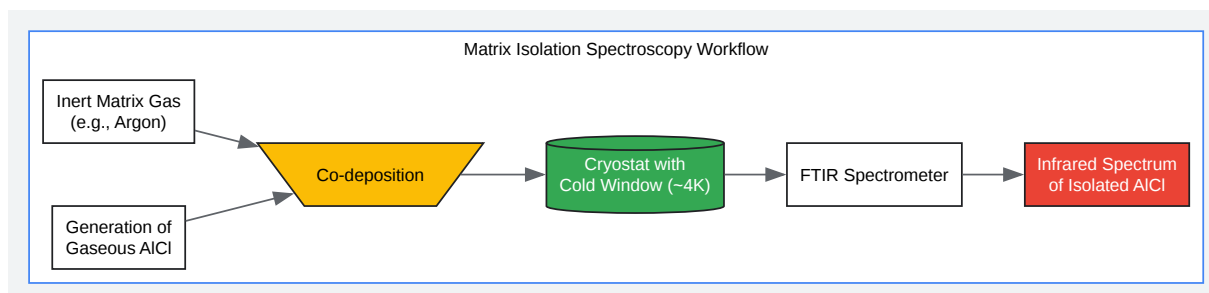

[Click to download full resolution via product page](#)

Workflow for matrix isolation infrared spectroscopy of AlCl.

## UV-Visible and Resonance-Enhanced Multiphoton Ionization (REMPI) Spectroscopy

Electronic spectroscopy in the UV-Visible region provides information about the excited electronic states of AlCl. The  $A^1\Pi \leftarrow X^1\Sigma^+$  transition is a well-studied system.[2][10] REMPI spectroscopy is a highly sensitive technique for studying the electronic states of molecules.

Experimental Protocol: REMPI Spectroscopy of AlCl

- Apparatus: A tunable pulsed laser system, a molecular beam apparatus for generating a jet-cooled beam of AlCl, and a time-of-flight mass spectrometer for ion detection.
- Procedure:
  - Generate a molecular beam of AlCl, often using laser ablation.
  - The molecules are cooled to very low rotational and vibrational temperatures by supersonic expansion.
  - The molecular beam is intersected by the tunable laser beam.

- When the laser is tuned to a resonant electronic transition, the molecule is excited.
- A second (or third) photon from the same or another laser pulse ionizes the excited molecule.
- The resulting ions are detected by the mass spectrometer.
- A spectrum is obtained by plotting the ion signal as a function of the laser wavelength, revealing the rovibronic structure of the excited electronic states.[11]

## Computational Studies

Ab initio and density functional theory (DFT) calculations have been instrumental in complementing experimental studies of **aluminum monochloride**. These computational methods provide valuable insights into the electronic structure, potential energy curves, spectroscopic constants, and thermodynamic properties of AlCl.[12] Theoretical studies have also been used to predict the properties of AlCl oligomers.[13]

## Logical Relationships in AlCl Chemistry

The chemistry of **aluminum monochloride** is intrinsically linked to that of aluminum trichloride and elemental aluminum, particularly in high-temperature environments.

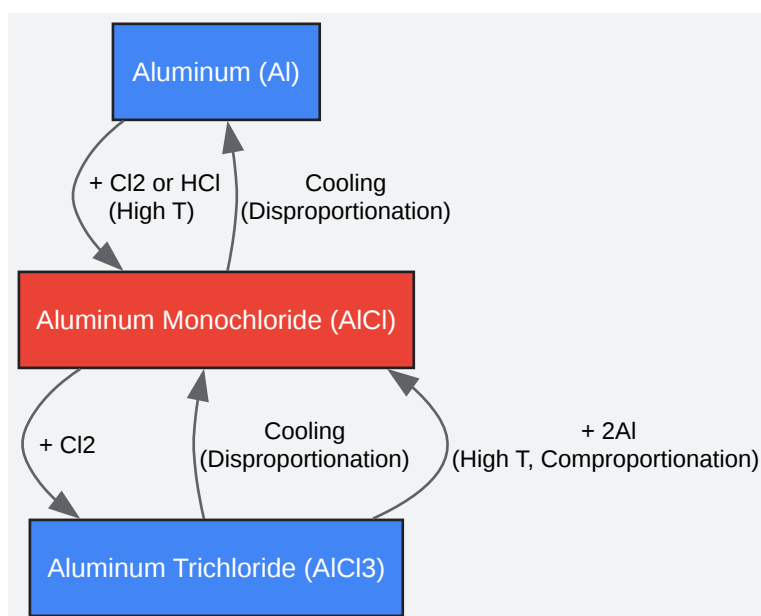

[Click to download full resolution via product page](#)

Key chemical relationships involving **aluminum monochloride**.

## Conclusion

**Aluminum monochloride**, while unstable under ambient conditions, is a fundamentally important diatomic molecule with a rich gas-phase chemistry and a well-characterized spectroscopic profile. This guide has provided a comprehensive overview of its properties, methods of in-situ generation, and the experimental protocols used for its characterization. For researchers and scientists in the physical sciences, an understanding of AlCl is crucial for applications in materials processing, high-temperature chemistry, and astrophysics. The detailed experimental workflows and tabulated data presented herein serve as a valuable technical resource for further investigation into this fascinating molecule.

### Need Custom Synthesis?

BenchChem offers custom synthesis for rare earth carbides and specific isotopic labeling.

Email: [info@benchchem.com](mailto:info@benchchem.com) or [Request Quote Online](#).

## References

- 1. Aluminium monochloride - Wikipedia [[en.wikipedia.org](https://en.wikipedia.org)]
- 2. [2105.01211] Spectroscopy on the  $A^1\Pi \leftarrow X^1\Sigma^+$  Transition of Buffer-Gas Cooled AlCl [[arxiv.org](https://arxiv.org)]
- 3. [pubs.aip.org](https://pubs.aip.org) [[pubs.aip.org](https://pubs.aip.org)]
- 4. Aluminium chloride (data page) - Wikipedia [[en.wikipedia.org](https://en.wikipedia.org)]
- 5. Aluminium chloride - Wikipedia [[en.wikipedia.org](https://en.wikipedia.org)]
- 6. Sciencemadness Discussion Board - AlCl<sub>3</sub> synthesis - Powered by XMB 1.9.11 [[sciencemadness.org](https://sciencemadness.org)]
- 7. OPG [[opg.optica.org](https://opg.optica.org)]
- 8. [pubs.aip.org](https://pubs.aip.org) [[pubs.aip.org](https://pubs.aip.org)]
- 9. HAICl and AlCl<sub>2</sub>: A matrix isolation ESR study for JACS - IBM Research [[research.ibm.com](https://research.ibm.com)]
- 10. Spectroscopy On Aluminum Monochloride (alcl) For Laser Cooling And Trapping | IDEALS [[ideals.illinois.edu](https://ideals.illinois.edu)]

- [11. researchgate.net \[researchgate.net\]](#)
- [12. arxiv.org \[arxiv.org\]](#)
- [13. researchgate.net \[researchgate.net\]](#)
- To cite this document: BenchChem. [A Comprehensive Technical Guide to Aluminum Monochloride]. BenchChem, [2026]. [Online PDF]. Available at: [\[https://www.benchchem.com/product/b080767/docs#a-comprehensive-technical-guide-to-aluminum-monochloride\]](https://www.benchchem.com/product/b080767/docs#a-comprehensive-technical-guide-to-aluminum-monochloride)

### Disclaimer & Data Validity:

The information provided in this document is for Research Use Only (RUO) and is strictly not intended for diagnostic or therapeutic procedures. While BenchChem strives to provide accurate protocols, we make no warranties, express or implied, regarding the fitness of this product for every specific experimental setup.

**Technical Support:** The protocols provided are for reference purposes. Unsure if this reagent suits your experiment?

**Need Industrial/Bulk Grade?** [Request Custom Synthesis Quote](#)

## BenchChem

Our mission is to be the trusted global source of essential and advanced chemicals, empowering scientists and researchers to drive progress in science and industry.

### Contact

Address: 3281 E Guasti Rd  
Ontario, CA 91761, United States  
Phone: (601) 213-4426  
Email: [info@benchchem.com](mailto:info@benchchem.com)

[Contact our Ph.D. Support Team for a compatibility check](#)

