

# Application Note: High-Efficiency Thioester Exchange with *S*-(2,4-Dimethylphenyl) Ethanethioate

**Author:** BenchChem Technical Support Team. **Date:** April 2026

## Compound of Interest

**Compound Name:** *S*-(2,4-Dimethylphenyl) ethanethioate  
**Cat. No.:** B7998603

[Get Quote](#)

## Executive Summary

Thioester exchange (transthioesterification) is the cornerstone of Native Chemical Ligation (NCL), kinetic resolution, and covalent fragment screening. While alkyl thioesters are stable but unreactive, and simple aryl thioesters (e.g., thiophenol) are reactive but noxious, ***S*-(2,4-Dimethylphenyl) ethanethioate** represents a "Goldilocks" reagent.

The 2,4-dimethyl substitution pattern on the leaving group provides two critical advantages:

- **Steric Modulation:** The ortho-methyl group provides steric shielding that suppresses non-specific hydrolysis while maintaining high reactivity toward thiolate nucleophiles.
- **Handling Profile:** Significantly reduced volatility and malodor compared to thiophenol, enabling safer benchtop handling.

This guide details the synthesis, kinetic characterization, and application of this reagent for controlled acyl transfer.

## Scientific Foundation & Mechanism

### The "Goldilocks" Reactivity

The efficiency of a thioester exchange reaction depends heavily on the pKa of the leaving group thiol.

- Alkyl Thiols (pKa ~10): Poor leaving groups. Exchange is slow and requires harsh catalysts.
- Thiophenol (pKa ~6.6): Excellent leaving group, but prone to hydrolysis and extremely malodorous.
- 2,4-Dimethylbenzenethiol (pKa ~6.8 - 7.0): The electron-donating methyl groups slightly increase the pKa compared to thiophenol, rendering the thioester more stable during storage. However, it remains sufficiently acidic to drive rapid exchange with alkyl thiols (e.g., Cysteine, pKa ~8.5) under physiological conditions.

### Reaction Mechanism

The reaction proceeds via a reversible nucleophilic attack on the carbonyl carbon. The stability of the S-(2,4-dimethylphenyl) leaving group drives the equilibrium forward when reacting with aliphatic thiols.

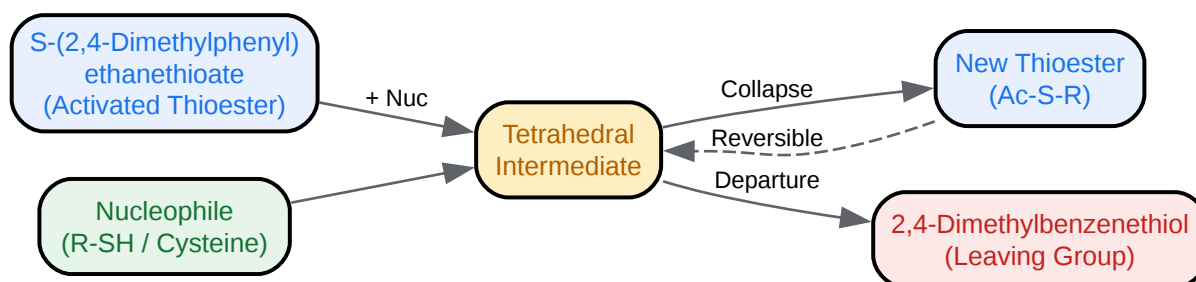

[Click to download full resolution via product page](#)

Figure 1: Mechanistic pathway of thioester exchange. The 2,4-dimethylphenyl moiety serves as an efficient leaving group, driving the formation of the more stable alkyl thioester.

## Experimental Protocols

## Protocol A: Synthesis of S-(2,4-Dimethylphenyl) Ethanethioate

Note: While commercially available, in-house preparation ensures freshness and eliminates hydrolysis byproducts.

Reagents:

- 2,4-Dimethylbenzenethiol (1.0 equiv)
- Acetyl Chloride (1.2 equiv)
- Triethylamine (1.5 equiv)
- Dichloromethane (DCM, anhydrous)

Step-by-Step Procedure:

- Setup: Flame-dry a 100 mL round-bottom flask (RBF) and purge with Nitrogen ( ). Add a magnetic stir bar.
- Solubilization: Dissolve 2,4-Dimethylbenzenethiol (10 mmol, 1.38 g) in anhydrous DCM (30 mL). Cool the solution to 0°C using an ice bath.
- Base Addition: Add Triethylamine (15 mmol, 2.1 mL) dropwise. The solution may slightly change color.<sup>[1]</sup>
- Acylation: Add Acetyl Chloride (12 mmol, 0.85 mL) dropwise over 10 minutes. Caution: Exothermic reaction.
- Reaction: Remove the ice bath and stir at Room Temperature (RT) for 2 hours. Monitor by TLC (Hexane:EtOAc 9:1). The thiol spot should disappear.
- Workup:
  - Quench with saturated

(30 mL).

- Extract with DCM (2 x 30 mL).
- Wash combined organics with 1M

(to remove residual amine), then Brine.

- Dry over anhydrous

and concentrate in vacuo.

- Purification: Flash chromatography (Silica gel, 0-5% EtOAc in Hexane) yields the product as a clear or pale yellow oil/low-melting solid.
  - Yield Expectation: >90%.[\[1\]](#)
  - Storage: -20°C, stable for months.

## Protocol B: Kinetic Thioester Exchange Assay

Objective: To quantify the reactivity of DMP-SAc against a model thiol (e.g., Benzyl Mercaptan or N-acetyl Cysteine methyl ester).

Materials:

- DMP-SAc (Reagent)
- Benzyl Mercaptan (Nucleophile)
- Internal Standard: 1,3,5-Trimethoxybenzene
- Solvent: Deuterated Chloroform ( ) or Phosphate Buffer (pH 7.0) with 20% (for aqueous mimicking).

Procedure:

- Stock Solutions: Prepare 100 mM stocks of DMP-SAc and Benzyl Mercaptan.
- Mixing: In an NMR tube, combine:
  - 0.3 mL DMP-SAc stock (Final: 50 mM)
  - 0.3 mL Benzyl Mercaptan stock (Final: 50 mM)
  - 10  $\mu$ L Internal Standard.
- Monitoring: Immediately insert into NMR spectrometer.
- Data Acquisition: Acquire  
-NMR spectra every 2 minutes for 60 minutes.
- Analysis: Track the disappearance of the acetyl methyl singlet of DMP-SAc (approx 2.4-2.5 ppm) and the appearance of the new thioester peak (approx 2.3 ppm).
- Rate Calculation: Plot  
vs. time to determine the pseudo-first-order rate constant ( ).

Data Output Format:

Time (min)	Reagent Conversion (%)	Product Formation (%)	Notes
0	0	0	Initiation
10	35	32	Fast initial burst
30	78	75	Equilibrium approaching
60	92	90	Plateau

## Protocol C: Chemoselective N-Terminal Acetylation (NCL Mimic)

Objective: Use DMP-SAc to specifically acetylate an N-terminal Cysteine peptide without affecting internal Lysines (at pH 7).

Context: Aryl thioesters react rapidly with N-terminal Cysteines via a 5-membered ring transition state (Native Chemical Ligation mechanism) but react slowly with amines at neutral pH.

Workflow Diagram:

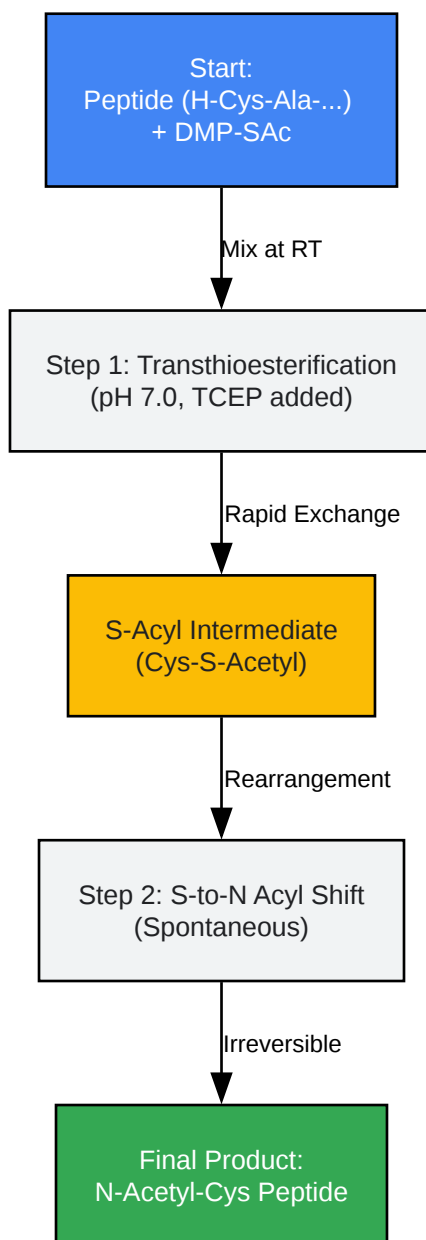

[Click to download full resolution via product page](#)

Figure 2: Chemoselective acetylation workflow mimicking Native Chemical Ligation.

Procedure:

- Peptide Dissolution: Dissolve peptide (e.g., H-Cys-Gly-Phe-OH, 5 mg) in 6M Guanidinium HCl / 200 mM Phosphate Buffer (pH 7.0). Final concentration: 2-5 mM.

- Additives: Add TCEP (Tris(2-carboxyethyl)phosphine) to 20 mM to keep the Cysteine reduced.
- Reaction: Add DMP-SAc (5 equivalents) dissolved in a minimal amount of DMF or Acetonitrile (10% v/v of total volume).
- Incubation: Vortex and let stand at 25°C.
- Monitoring: Analyze by LC-MS at T=0, 15 min, 1h, 4h.
  - Success Criteria: Mass shift of +42 Da (Acetyl).
  - Selectivity Check: If Lysines are present, ensure no +84 Da (double acetylation) species appear at early time points.
- Quenching: Acidify with 0.1% TFA and purify via HPLC.

## Troubleshooting & Optimization

Issue	Probable Cause	Solution
Slow Reaction Rate	Oxidation of Nucleophile	Increase TCEP concentration to 50 mM. Ensure pH is > 6. [2]5.
Hydrolysis of Reagent	pH too high (>8.0)	Maintain pH between 6.8 and 7.5. The aryl thioester is base-sensitive.
Precipitation	Reagent insolubility	Increase organic co-solvent (Acetonitrile/DMF) up to 30% v/v.
"Stench" Leakage	Poor ventilation	While "low odor", the free thiol byproduct still smells. Quench waste with bleach (NaOCl) to oxidize thiol to sulfonate.

## References

- Mechanism of Thiol-Thioester Exchange
  - Title: Theoretical investigations on the thiol-thioester exchange steps of different thioesters.[3]
  - Source: RHHZ.net / Vertex AI Search.
  - URL:[[Link](#)]
- Kinetics of Aryl vs Alkyl Thioesters
  - Title: The relative rates of thiol-thioester exchange and hydrolysis for alkyl and aryl thioalkanoates in w
  - Source: PubMed / NIH.
  - URL:[[Link](#)]
- Native Chemical Ligation Methodology
  - Title: Native Chemical Ligation of Peptides and Proteins.[2][4][5][6][7][8][9][10]
  - Source: PMC / NIH.
  - URL:[[Link](#)]
- Thioester Preparation (General)
  - Title: Organic Syntheses Procedure: Preparation of S-Aryl Thioacetates.[11]
  - Source: Organic Syntheses.[12]
  - URL:[[Link](#)]
- Title: S-(2,4-Dimethylphenyl)

### ***Need Custom Synthesis?***

*BenchChem offers custom synthesis for rare earth carbides and specific isotopic labeling.*

*Email: [info@benchchem.com](mailto:info@benchchem.com) or [Request Quote Online](#).*

## Sources

- [1. Organic Syntheses Procedure \[orgsyn.org\]](#)
- [2. Kinetic and Mechanistic Studies of Native Chemical Ligation with Phenyl  \$\alpha\$ -Selenoester Peptides - PMC \[pmc.ncbi.nlm.nih.gov\]](#)
- [3. Theoretical investigations on the thiol-thioester exchange steps of different thioesters \[html.rhhz.net\]](#)
- [4. Native Chemical Ligation: A Boon to Peptide Chemistry \[mdpi.com\]](#)
- [5. Reactivity of thioesters in biochemistry and native chemical ligation - American Chemical Society \[acs.digitellinc.com\]](#)
- [6. chemistry.illinois.edu \[chemistry.illinois.edu\]](#)
- [7. Selective Activation of Peptide-Thioester Precursors for Templated Native Chemical Ligations - PubMed \[pubmed.ncbi.nlm.nih.gov\]](#)
- [8. Native chemical ligation - Wikipedia \[en.wikipedia.org\]](#)
- [9. researchgate.net \[researchgate.net\]](#)
- [10. EP0832096B1 - Synthesis of proteins by native chemical ligation - Google Patents \[patents.google.com\]](#)
- [11. pdf.benchchem.com \[pdf.benchchem.com\]](#)
- [12. rsc.org \[rsc.org\]](#)
- To cite this document: BenchChem. [Application Note: High-Efficiency Thioester Exchange with S-(2,4-Dimethylphenyl) Ethanethioate]. BenchChem, [2026]. [Online PDF]. Available at: [<https://www.benchchem.com/product/b7998603/docs#application-note-high-efficiency-thioester-exchange-with-s-2-4-dimethylphenyl-ethanethioate>]

---

### Disclaimer & Data Validity:

The information provided in this document is for Research Use Only (RUO) and is strictly not intended for diagnostic or therapeutic procedures. While BenchChem strives to provide accurate protocols, we make no warranties, express or implied, regarding the fitness of this product for every specific experimental setup.

**Technical Support:** The protocols provided are for reference purposes. Unsure if this reagent suits your experiment?

**Need Industrial/Bulk Grade?** [Request Custom Synthesis Quote](#)

## BenchChem

Our mission is to be the trusted global source of essential and advanced chemicals, empowering scientists and researchers to drive progress in science and industry.

### Contact

Address: 3281 E Guasti Rd  
Ontario, CA 91761, United States  
Phone: (601) 213-4426  
Email: [info@benchchem.com](mailto:info@benchchem.com)

[Contact our Ph.D. Support Team for a compatibility check](#)