

Application Note: In Vitro Enzyme Kinetics of 3-Hydroxypropionate Dehydrogenase (3-HPDH)

Author: BenchChem Technical Support Team. **Date:** April 2026

Compound of Interest

Compound Name: sodium;3-hydroxypropanoate

Cat. No.: B7983827

[Get Quote](#)

Abstract

3-Hydroxypropionate dehydrogenase (3-HPDH; EC 1.1.1.[1][2][3][4][5][6][7]59) is a pivotal oxidoreductase catalyzing the reversible interconversion of 3-hydroxypropionate (3-HP) and malonate semialdehyde.[5] As a cornerstone enzyme in the 3-hydroxypropionate cycle for CO₂ fixation and a critical node in synthetic pathways for bioplastic precursors, accurate kinetic characterization of 3-HPDH is essential. This guide provides a rigorous, standardized protocol for determining the kinetic parameters (

,

,

) of 3-HPDH. We focus on the oxidative assay (3-HP

Malonate Semialdehyde) due to substrate stability, utilizing real-time spectrophotometric monitoring of NADH formation.

Introduction & Mechanistic Insight

Biological Context

3-HPDH belongs to the Short-Chain Dehydrogenase/Reductase (SDR) superfamily.[5] In metabolic engineering, it is the rate-limiting step in converting malonyl-CoA or

-alanine into 3-HP, a platform chemical used for acrylic acid production. In autotrophic archaea like *Metallosphaera sedula*, it functions in the 3-hydroxypropionate/4-hydroxybutyrate cycle to fix carbon.[6][8][9]

Reaction Mechanism

The enzyme catalyzes the hydride transfer from the C3-hydroxyl group of 3-hydroxypropionate to the C4 of the nicotinamide ring of NAD(P)⁺.

Critical Experimental Consideration: The equilibrium constant (

) for alcohol oxidation typically favors the alcohol (3-HP) and NAD⁺ at neutral pH. To accurately measure oxidation kinetics, the assay must be performed at a basic pH (9.0–10.0) or include a trapping agent (like hydrazine) to remove the aldehyde product, driving the reaction forward (mass action law).

Experimental Design Strategy

To ensure data integrity (E-E-A-T), this protocol avoids common pitfalls such as substrate inhibition and buffer interference.

- Detection Method: Continuous spectrophotometry at 340 nm (for NADH).[10]
- Directionality: We prioritize the Oxidation Assay (3-HP as substrate).
 - Reasoning: Malonate semialdehyde is chemically unstable (prone to polymerization and decarboxylation) and difficult to purchase in pure form. 3-HP is stable and commercially available.
- Cofactor Specificity: While EC 1.1.1.59 is NAD-dependent, engineered variants may prefer NADP⁺. This protocol uses NAD⁺ but is adaptable for NADP⁺. [5]

Reaction Scheme Visualization

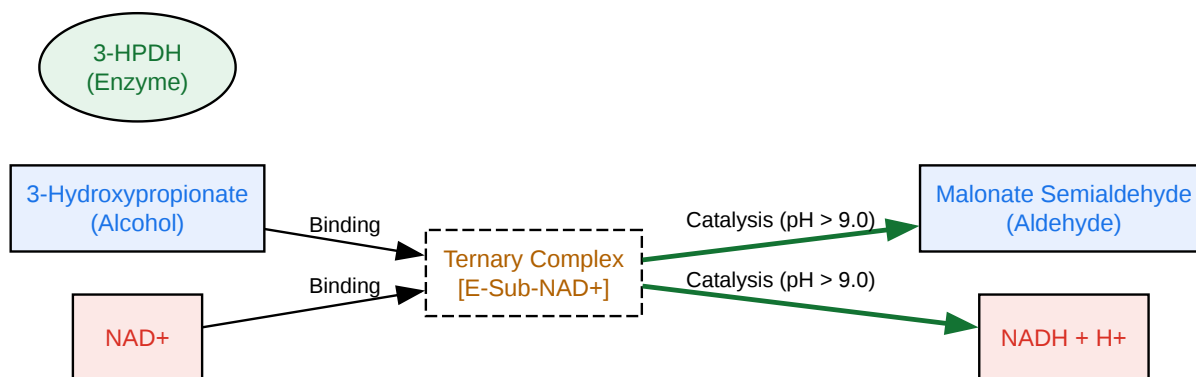

Figure 1: Bi-Bi reaction mechanism. High pH drives equilibrium to the right.

[Click to download full resolution via product page](#)

Materials & Reagents

All reagents must be Analytical Grade or higher.

Component	Specification	Storage	Role
Buffer	100 mM Glycine-NaOH, pH 9.5	4°C	Maintains alkaline pH to drive oxidation.
Substrate	Sodium 3-hydroxypropionate (3-HP)	-20°C	Primary substrate. Prepare fresh 100 mM stock.
Cofactor	NAD ⁺ (Free Acid)	-20°C	Electron acceptor. Prepare 50 mM stock (neutralized).
Enzyme	Purified 3-HPDH	-80°C	Target catalyst. Dilute in enzyme dilution buffer on ice.
Control	BSA (Bovine Serum Albumin)	4°C	Protein stabilizer for dilute enzyme.
Water	Milli-Q / Nuclease-free	RT	Solvent.

Note on Hydrazine: Some legacy protocols use hydrazine to trap the aldehyde. We omit this for the standard kinetic assay to avoid side reactions with the enzyme, unless

cannot be reached due to rapid product inhibition.

Detailed Protocol: Spectrophotometric Assay

Enzyme Preparation[11]

- Thaw enzyme on ice.
- Dilute enzyme in Dilution Buffer (50 mM Potassium Phosphate, pH 7.5, 1 mM DTT, 10% Glycerol) to a concentration where

is linear for at least 2 minutes (target rate: 0.05 – 0.15 AU/min).
- Self-Validation Check: If the rate is > 0.2 AU/min, the reaction is too fast for accurate initial velocity (

) determination; dilute further.

Assay Workflow (96-Well Plate or Cuvette)

The following is scaled for a 200 μ L microplate reaction pathlength correction required (cm) or standard 1 cm cuvette.

Step-by-Step Procedure:

- Blank Preparation: Prepare a "No Substrate" blank and a "No Enzyme" blank to account for NADH spontaneous generation or background absorbance.
- Master Mix: Prepare fresh Master Mix (Buffer + NAD⁺).
- Initiation:
 - Pipette Buffer, NAD⁺, and Enzyme into the well.
 - Incubate at 25°C (or physiological temp) for 3 minutes to equilibrate.

- Add 3-HP to start the reaction.[11]
- Measurement: Immediately monitor Absorbance at 340 nm every 10 seconds for 5–10 minutes.

Pipetting Scheme (Standard 1 mL Cuvette)

Reagent	Volume (μL)	Final Conc.
Glycine-NaOH (pH 9.5, 100 mM)	880 - X	90 mM
NAD ⁺ Stock (50 mM)	50	2.5 mM (Saturating)
Enzyme Solution	20	~0.1–1 μg/mL
3-HP Substrate (Variable)	X (e.g., 50)	0.1 – 20 mM
Total Volume	1000 μL	

Determination of Kinetic Parameters (,)

To determine

for 3-HP, vary 3-HP concentration while keeping NAD⁺ constant (saturating, e.g., 2.5 mM).

Substrate Titration Range

Prepare 3-HP concentrations spanning 0.2

to 10

. Based on literature (typical

mM):

- Points (mM): 0, 0.25, 0.5, 1.0, 2.5, 5.0, 10.0, 20.0.

Data Analysis Workflow

- Calculate Initial Velocity (

-) : Determine the slope () of the linear portion of the curve (usually first 60–120 seconds).
- [10]
 - (cuvette) or pathlength correction (plate).
 - Michaelis-Menten Fitting: Plot vs. [Substrate]. Fit data to the Michaelis-Menten equation using non-linear regression (GraphPad Prism, Origin, or Python scipy).
 - Calculate :
 - Ensure is in molar units (requires enzyme molecular weight).

Experimental Logic Flowchart

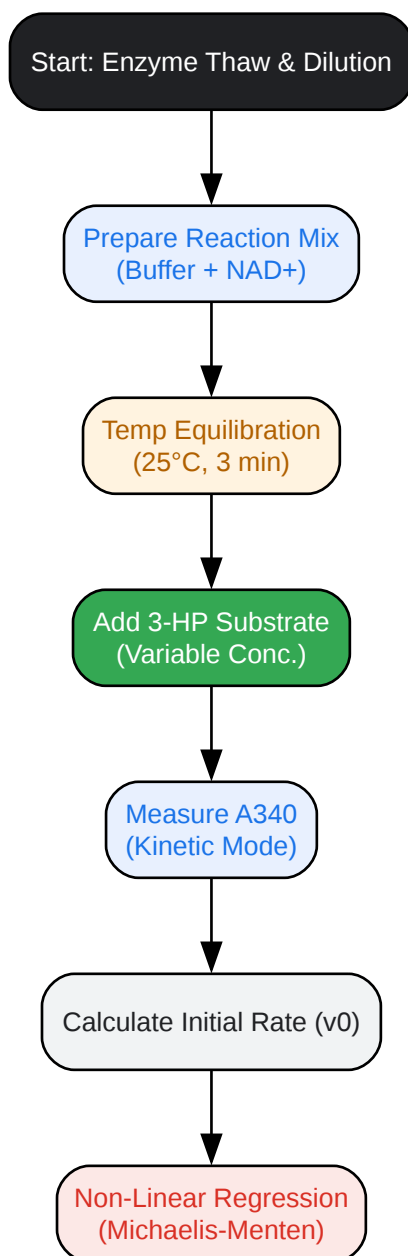

Figure 2: Kinetic Assay Workflow

[Click to download full resolution via product page](#)

Troubleshooting & Optimization (Expertise)

Issue	Probable Cause	Corrective Action
Non-linear initial rate	Enzyme instability or product inhibition.	Add 0.1% BSA to enzyme diluent. Measure shorter interval (0–30s).
High Background	Impure NAD ⁺ or spontaneous oxidation.	Use fresh NAD ⁺ . Check buffer pH (too high can degrade NAD ⁺).
No Activity	Wrong pH or oxidative damage to enzyme.	Check pH (must be >9.0 for oxidation). Add 1 mM DTT to enzyme stock (SDR enzymes often have catalytic cysteines).
Substrate Inhibition	[3-HP] too high.	Check if rate decreases at [S] > 10 mM. Fit to Haldane equation if observed.

References

- Den, H., Robinson, W. G., & Coon, M. J. (1959). -hydroxypropionate to malonic semialdehyde.[1][4] *Journal of Biological Chemistry*, 234(7), 1666-1671.[1]
- Kockelkorn, D., & Fuchs, G. (2009). Malonic semialdehyde reductase, succinic semialdehyde reductase, and succinyl-coenzyme A reductase from *Metallosphaera sedula*: enzymes of the autotrophic 3-hydroxypropionate/4-hydroxybutyrate cycle in Sulfolobales. *Journal of Bacteriology*, 191(20), 6352-6362.
- Loder, A. J., et al. (2016). Reaction kinetic analysis of the 3-hydroxypropionate/4-hydroxybutyrate CO₂ fixation cycle in extremely thermoacidophilic archaea.[8] *Metabolic Engineering*, 38, 446-463.

Need Custom Synthesis?

BenchChem offers custom synthesis for rare earth carbides and specific isotopic labeling.

Email: info@benchchem.com or [Request Quote Online](#).

Sources

- [1. 3-hydroxypropionate dehydrogenase - Wikipedia \[en.wikipedia.org\]](#)
- [2. ENZYME - 1.1.1.59 3-hydroxypropionate dehydrogenase \[enzyme.expasy.org\]](#)
- [3. KEGG ENZYME: 1.1.1.59 \[genome.jp\]](#)
- [4. EC 1.1.1.59 \[iubmb.qmul.ac.uk\]](#)
- [5. grokipedia.com \[grokipedia.com\]](#)
- [6. researchgate.net \[researchgate.net\]](#)
- [7. Enzyme Activity Measurement for 3-Hydroxypropionate Dehydrogenase Using Spectrophotometric Assays \[creative-enzymes.com\]](#)
- [8. Reaction kinetic analysis of the 3-hydroxypropionate/4-hydroxybutyrate CO₂ fixation cycle in extremely thermoacidophilic archaea \(Journal Article\) | OSTI.GOV \[osti.gov\]](#)
- [9. Reaction Kinetic Analysis of the 3-Hydroxypropionate/4-Hydroxybutyrate CO₂ Fixation Cycle in Extremely Thermoacidophilic Archaea - PMC \[pmc.ncbi.nlm.nih.gov\]](#)
- [10. scispace.com \[scispace.com\]](#)
- [11. journals.asm.org \[journals.asm.org\]](#)
- [To cite this document: BenchChem. \[Application Note: In Vitro Enzyme Kinetics of 3-Hydroxypropionate Dehydrogenase \(3-HPDH\)\]. BenchChem, \[2026\]. \[Online PDF\]. Available at: \[https://www.benchchem.com/product/b7983827/docs#application-note-in-vitro-enzyme-kinetics-of-3-hydroxypropionate-dehydrogenase-3-hpdh\]](#)

Disclaimer & Data Validity:

The information provided in this document is for Research Use Only (RUO) and is strictly not intended for diagnostic or therapeutic procedures. While BenchChem strives to provide accurate protocols, we make no warranties, express or implied, regarding the fitness of this product for every specific experimental setup.

Technical Support: The protocols provided are for reference purposes. Unsure if this reagent suits your experiment?

Need Industrial/Bulk Grade? [Request Custom Synthesis Quote](#)

BenchChem

Our mission is to be the trusted global source of essential and advanced chemicals, empowering scientists and researchers to drive progress in science and industry.

Contact

Address: 3281 E Guasti Rd

Ontario, CA 91761, United States

Phone: (601) 213-4426

Email: info@benchchem.com

[Contact our Ph.D. Support Team for a compatibility check](#)