

2-(2-Chlorophenyl)-2-methylbutanoic acid chemical structure analysis

Author: BenchChem Technical Support Team. **Date:** April 2026

Compound of Interest

Compound Name: 2-(2-Chlorophenyl)-2-methylbutanoic acid

Cat. No.: B7968781

[Get Quote](#)

An In-Depth Technical Guide to **2-(2-Chlorophenyl)-2-methylbutanoic Acid**: Synthesis, Characterization, and Potential Applications

Abstract

This technical guide provides a comprehensive analysis of **2-(2-Chlorophenyl)-2-methylbutanoic acid**, a chiral α -arylalkanoic acid. While not extensively documented in public literature, its structural motifs are shared with numerous pharmacologically active compounds, particularly non-steroidal anti-inflammatory drugs (NSAIDs). This document, intended for researchers and drug development professionals, delineates the molecule's structural features, predicts its physicochemical and spectroscopic properties, and presents detailed, field-proven synthetic methodologies. We explore two primary synthetic routes—Grignard reagent carboxylation and Phase-Transfer Catalyzed (PTC) alkylation—explaining the causal chemistry behind each protocol. Furthermore, a full, predicted spectroscopic profile (^1H NMR, ^{13}C NMR, IR, MS) is provided to aid in the identification and validation of the synthesized compound. The guide concludes with a discussion of its potential applications as a pharmaceutical or agrochemical intermediate and outlines future research directions.

Molecular Structure and Physicochemical Properties

IUPAC Nomenclature and Structural Analysis

The compound is systematically named **2-(2-Chlorophenyl)-2-methylbutanoic acid**. Its structure features a butanoic acid backbone with two substituents on the alpha-carbon (C2): a methyl group and a 2-chlorophenyl group. This substitution pattern creates a chiral center at C2, meaning the molecule exists as a pair of enantiomers, (R)- and (S)-**2-(2-Chlorophenyl)-2-methylbutanoic acid**. The presence of the chlorine atom on the ortho position of the phenyl ring introduces steric hindrance and alters the electronic properties of the aromatic system, which can significantly influence both its chemical reactivity and potential biological activity.

Caption: Figure 1: Structure of **2-(2-Chlorophenyl)-2-methylbutanoic acid**.

Predicted Physicochemical Properties

Quantitative prediction of molecular properties is essential for experimental design, including solvent selection and purification strategy. The properties for the target molecule have been estimated using computational models and comparison with analogous structures.

Property	Predicted Value	Source/Basis
Molecular Formula	C ₁₁ H ₁₃ ClO ₂	-
Molecular Weight	212.67 g/mol	[1]
LogP	3.1 - 3.3	[1][2]
pKa	~4.8	Analogy to 2-methylbutanoic acid[3]
Topological Polar Surface Area (TPSA)	37.3 Å ²	[1]
Hydrogen Bond Donors	1	[1]
Hydrogen Bond Acceptors	2	[3]
Rotatable Bonds	3	[1]

Synthesis Methodologies

The synthesis of α,α -disubstituted carboxylic acids can be approached from several angles. The choice of method depends on factors such as starting material availability, scalability, and tolerance to functional groups. We present two robust and well-established methods applicable to the target molecule.

Retrosynthetic Analysis

A retrosynthetic approach reveals two logical disconnections pointing towards viable starting materials. The primary disconnection is at the C-COOH bond, suggesting a Grignard reagent and CO₂. A secondary disconnection at the α -carbon C-C bond suggests an alkylation of a phenylacetic acid precursor.

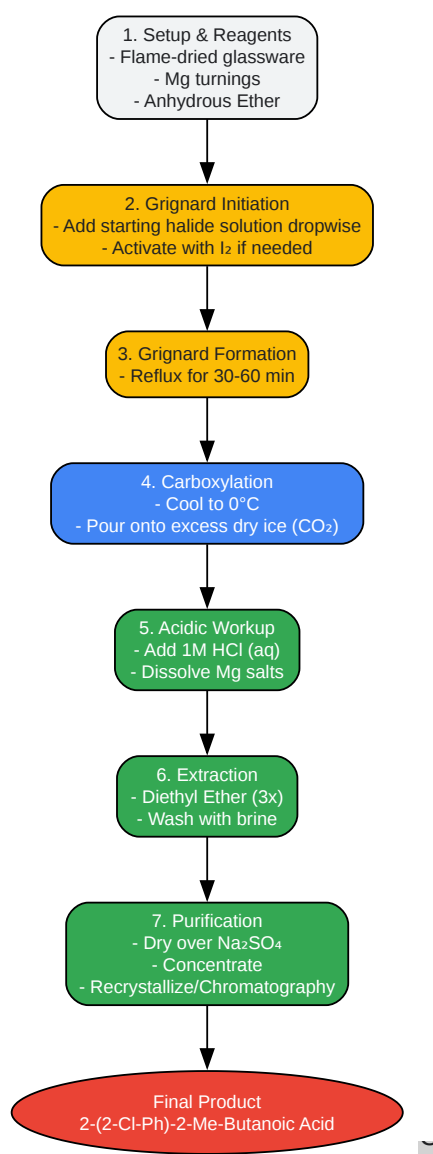
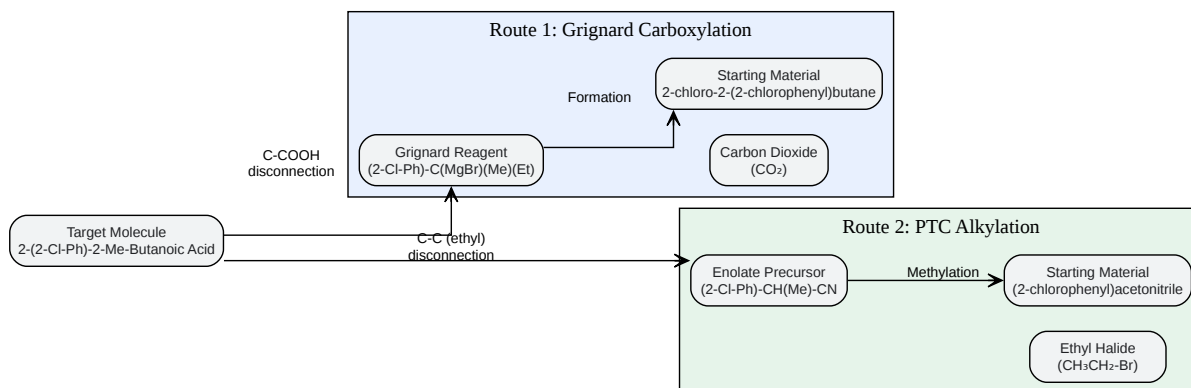

[Click to download full resolution via product page](#)

Need Custom Synthesis?

BenchChem offers custom synthesis for rare earth carbides and specific isotopic labeling.

Email: info@benchchem.com or [Request Quote Online](#).

Sources

- [1. chemscene.com \[chemscene.com\]](https://chemscene.com)
- [2. PubChemLite - 3-\(2-chlorophenyl\)-2-methylbutanoic acid \(C11H13ClO2\) \[pubchemlite.lcsb.uni.lu\]](https://pubchemlite.lcsb.uni.lu)
- [3. Showing Compound 2-Methylbutanoic acid \(FDB008135\) - FooDB \[foodb.ca\]](https://foodb.ca)
- To cite this document: BenchChem. [2-(2-Chlorophenyl)-2-methylbutanoic acid chemical structure analysis]. BenchChem, [2026]. [Online PDF]. Available at: [\[https://www.benchchem.com/product/b7968781/docs#2-2-chlorophenyl-2-methylbutanoic-acid-chemical-structure-analysis\]](https://www.benchchem.com/product/b7968781/docs#2-2-chlorophenyl-2-methylbutanoic-acid-chemical-structure-analysis)

Disclaimer & Data Validity:

The information provided in this document is for Research Use Only (RUO) and is strictly not intended for diagnostic or therapeutic procedures. While BenchChem strives to provide accurate protocols, we make no warranties, express or implied, regarding the fitness of this product for every specific experimental setup.

Technical Support: The protocols provided are for reference purposes. Unsure if this reagent suits your experiment?

Need Industrial/Bulk Grade? [Request Custom Synthesis Quote](#)

BenchChem

Our mission is to be the trusted global source of essential and advanced chemicals, empowering scientists and researchers to drive progress in science and industry.

Contact

Address: 3281 E Guasti Rd

Ontario, CA 91761, United States

Phone: (601) 213-4426

Email: info@benchchem.com

[Contact our Ph.D. Support Team for a compatibility check](#)