

common pitfalls in acetylated fructose experiments

Author: BenchChem Technical Support Team. **Date:** April 2026

Compound of Interest

Compound Name: *1,2,3,4,5-Penta-O-acetyl-beta-D-fructose*

Cat. No.: *B7959042*

[Get Quote](#)

Technical Support Center: Acetylated Fructose Optimization Ticket ID: #FRU-AC-9982 Status: Open Assigned Specialist: Dr. A. Vance, Senior Application Scientist

Executive Summary

You are likely accessing this guide because your acetylated fructose product is persisting as a viscous, non-crystallizing syrup, or your NMR spectra show an inexplicable "forest" of peaks despite a clean TLC.

Acetylation of D-fructose is fundamentally different from D-glucose due to the ketose moiety's high mutarotational lability. Unlike glucose, which stably favors the pyranose form, fructose exists in a delicate equilibrium of

-pyranose and

-furanose forms. Standard acetylation protocols often "freeze" this equilibrium, resulting in a complex isomeric mixture rather than a single pure compound.

This guide provides the protocols to force thermodynamic control and troubleshooting steps to salvage "failed" syrupy batches.

Module 1: Reaction Control & Isomer Selectivity

User Question: "I followed a standard acetic anhydride/pyridine protocol, but my product is a yellow oil that won't crystallize. Is it impure?"

Technical Diagnosis: It is likely chemically pure but isomerically mixed. Standard acetylation at Room Temperature (RT) is kinetically controlled, trapping the fructose in whatever ratio of pyranose/furanose exists in the solvent at that moment. To obtain crystalline

-D-fructopyranose pentaacetate, you must force the reaction toward the thermodynamic product.

The Protocol: Thermodynamic Forcing (ZnCl₂ Method) Use this method to maximize the yield of the stable pyranose form, which is easier to crystallize.

- Catalyst Preparation: Use anhydrous Zinc Chloride (ZnCl₂). Critical: Fuse the ZnCl₂ under vacuum prior to use to remove moisture, as water competes with the anhydride.
- Low-Temp Addition: Suspend dried D-fructose in Acetic Anhydride (Ac₂O) at -15°C to -10°C.
- Slow Addition: Add the ZnCl₂ slowly. The Lewis acid catalyzes the opening and closing of the ring, allowing the sugar to equilibrate to its most stable form (-pyranose) before the acetyl groups lock the structure.
- Work-up: Pour into ice water. The -pyranose isomer is less soluble and more likely to precipitate than the furanose oils.

Data Comparison: Catalyst Impact on Isomer Distribution

Catalyst System	Condition	Major Product	Physical State
Pyridine / Ac ₂ O	0°C	Mixture (Viscous Syrup
	RT	-pyranose + furanoses)	
NaOAc / Ac ₂ O	90°C (Hot)	Furanose enriched (Kinetic/High E)	Dark Oil
ZnCl ₂ / Ac ₂ O	-15°C	-D-fructopyranose (Thermodynamic)	Crystalline Solid

“

Expert Insight: If you must use pyridine (e.g., for acid-sensitive substrates), keep the temperature strictly below 0°C during addition to minimize furanose formation, though yield of the crystalline isomer will be lower than with ZnCl₂.

Module 2: Visualization of Isomeric Trapping

The following diagram illustrates how reaction conditions dictate whether you obtain a pure crystal or a mixed syrup.

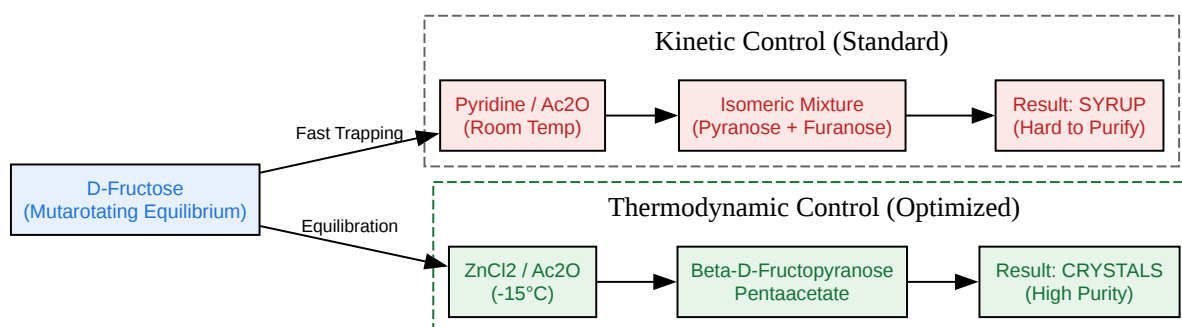

[Click to download full resolution via product page](#)

Figure 1: Kinetic vs. Thermodynamic trapping of fructose isomers. Standard basic conditions often lead to inseparable syrups.

Module 3: Purification & Stability Pitfalls

User Question: "My crude yield was 90%, but after silica column chromatography, I recovered only 60%, and the product turned dark. What happened?"

Technical Diagnosis: You likely experienced acid-catalyzed hydrolysis or acetyl migration on the silica gel. Silica is naturally acidic (pH ~4-5). Acetylated ketoses are more sensitive to acid hydrolysis than their aldose (glucose) counterparts due to the stability of the tertiary carbocation intermediate at the anomeric position.

The Protocol: Neutralized Flash Chromatography Never run acetylated sugars on "naked" silica gel.

- The Pre-Wash: Prepare your column slurry. Before loading the sample, flush the column with a solvent system containing 1% Triethylamine (Et₃N).
- The Eluent: Run your separation using Hexanes:Ethyl Acetate (typically 2:1 or 3:1), but maintain 0.1% Et₃N in the mobile phase to buffer the silica acidity.
- Alternative: Use Neutral Alumina instead of silica gel for highly sensitive furanose derivatives.

Module 4: Analytical Troubleshooting (NMR)

User Question: "My 1H NMR has multiple doublets in the anomeric region (5.0 - 6.5 ppm). Is my reagent contaminated?"

Technical Diagnosis: This is the hallmark of an isomeric mixture, not necessarily chemical contamination. Fructose lacks an anomeric proton in the same sense as aldoses (C1 is CH₂OAc), so you are looking at the H-3/H-4/H-5 region which shifts significantly between ring forms.

Diagnostic Checklist:

- Check ^{13}C NMR (The definitive test):
 - Pyranose Anomeric Carbon (C2): Resonates around 107-109 ppm.
 - Furanose Anomeric Carbon (C2): Resonates downfield around 102-105 ppm.
 - If you see peaks in both regions, you have a ring-size mixture.
- Integration Check:
 - In ^1H NMR, integrate the acetate methyl groups (~2.0-2.2 ppm). A pure pentaacetate should have 5 distinct singlets (or overlapping singlets integrating to 15H).
 - If you see small "shadow" peaks near the acetate signals, these are the minor anomers.

References

- Title: A comparative nuclear magnetic resonance study of acetylated D-fructose derivatives.
- Title: Anomeric Distribution of Sugar Acetates Synthesized via Peracetylation of Monosaccharides under Acidic and Basic Conditions.
- Lewis Acid Catalysis (ZnCl_2)
 - Title: A rapid and convenient synthesis of alpha and beta forms of acetylated derivatives of sugars.
 - Source: Indian Journal of Chemistry.
 - URL
- Silica Gel Interactions
 - Title: Construction of Modified Silica Gel Catalysts and Their Enhancement of Fructose Dehydration.[1]
 - Source: MDPI (C
 - URL

Need Custom Synthesis?

BenchChem offers custom synthesis for rare earth carbides and specific isotopic labeling.

Email: info@benchchem.com or [Request Quote Online](#).

Sources

- 1. Multiple Brønsted acidic sites in nitrogen-rich dicyandiamide immobilized on silica gel as a heterogeneous catalyst for efficient conversion of fructose into 5-hydroxymethylfurfural - Reaction Chemistry & Engineering (RSC Publishing) [pubs.rsc.org]
- To cite this document: BenchChem. [common pitfalls in acetylated fructose experiments]. BenchChem, [2026]. [Online PDF]. Available at: [<https://www.benchchem.com/product/b7959042/docs#common-pitfalls-in-acetylated-fructose-experiments>]

Disclaimer & Data Validity:

The information provided in this document is for Research Use Only (RUO) and is strictly not intended for diagnostic or therapeutic procedures. While BenchChem strives to provide accurate protocols, we make no warranties, express or implied, regarding the fitness of this product for every specific experimental setup.

Technical Support: The protocols provided are for reference purposes. Unsure if this reagent suits your experiment?

Need Industrial/Bulk Grade? [Request Custom Synthesis Quote](#)

BenchChem

Our mission is to be the trusted global source of essential and advanced chemicals, empowering scientists and researchers to drive progress in science and industry.

Contact

Address: 3281 E Guasti Rd
Ontario, CA 91761, United States
Phone: (601) 213-4426
Email: info@benchchem.com

Contact our Ph.D. Support Team for a compatibility check