

Technical Guide: Toxicity Profiling & Safety Management of 1,7-Naphthyridine Derivatives

Author: BenchChem Technical Support Team. **Date:** April 2026

Compound of Interest

Compound Name: *8-Amino-1,7-naphthyridine-5-carboxylic acid*

Cat. No.: *B7950191*

[Get Quote](#)

Executive Summary: The Double-Edged Scaffold

The 1,7-naphthyridine scaffold is a "privileged structure" in modern medicinal chemistry, widely utilized as a bioisostere for quinoline and isoquinoline in kinase inhibitors (e.g., p38 MAP kinase, PIP4K2A) and antimicrobial agents (DNA gyrase inhibitors). Its ability to form critical hydrogen bonds via the N1 and N7 atoms makes it potent; however, these same physicochemical properties introduce specific toxicity liabilities.

This guide moves beyond generic safety advice to address the specific toxicological risks associated with this heterocyclic core—specifically hERG channel blockade, genotoxicity, and metabolic bioactivation—and provides actionable protocols for safe handling and risk assessment.

Hazard Identification & GHS Classification

While specific Safety Data Sheets (SDS) vary by derivative, the core 1,7-naphthyridine scaffold and its common functionalized analogs share a hazard profile driven by their basicity and lipophilicity.

Representative GHS Classification

Based on aggregated data for 1,7-naphthyridine and low-molecular-weight derivatives.

Hazard Class	Category	Hazard Statement	Signal Word
Acute Toxicity (Oral)	Cat 4	H302: Harmful if swallowed.	Warning
Skin Irritation	Cat 2	H315: Causes skin irritation.	Warning
Eye Irritation	Cat 2A	H319: Causes serious eye irritation.	Warning
STOT - Single Exp.	Cat 3	H335: May cause respiratory irritation.	Warning
Aquatic Toxicity	Cat 2	H411: Toxic to aquatic life with long-lasting effects.	Warning

“

Critical Note: Many 1,7-naphthyridine derivatives are designed to bind DNA or inhibit kinases. Therefore, they should be treated as Suspected Carcinogens (Carc. 2) or Reproductive Toxins (Repr. 2) until specific Ames and in vivo data prove otherwise.

Toxicological Mechanisms: The "Why" Behind the Hazard

Understanding the mechanism of toxicity is essential for designing safer analogs and handling these compounds correctly.

Cardiotoxicity: The hERG Liability

The 1,7-naphthyridine core is a known pharmacophore for hERG potassium channel inhibition, which can lead to QT interval prolongation and fatal arrhythmias (Torsades de Pointes).

- Mechanism: The basic nitrogen at position 7 (N7) often becomes protonated at physiological pH. This positive charge can interact with the aromatic residues (Tyr652 and Phe656) inside the hERG channel pore via cation-

interactions.
- SAR Insight: Lipophilic substituents on the ring system increase hERG affinity. Reducing lipophilicity (lowering cLogP) or reducing the basicity of the N7 nitrogen is a common medicinal chemistry strategy to mitigate this risk [1].

Genotoxicity & DNA Intercalation

- Mechanism: The planar, bicyclic aromatic structure allows for potential intercalation between DNA base pairs, causing frameshift mutations.
- Enzymatic Target: Some derivatives act as bacterial Type II topoisomerase inhibitors (NBTI). [1][2] While this is the desired mechanism for antibiotics, high structural similarity to mammalian topoisomerase inhibitors can lead to mammalian genotoxicity [2].

Metabolic Bioactivation

- Pathway: The electron-deficient ring system is susceptible to oxidative metabolism by Cytochrome P450 enzymes (CYP3A4, CYP2D6).
- Reactive Intermediates:
 - N-Oxidation: Formation of N-oxides at N1 or N7.
 - Epoxidation: Oxidation across the C5-C6 or C3-C4 bond can form unstable epoxide intermediates, which may covalently bind to proteins (hapttenization), leading to idiosyncratic toxicity or immune responses [3].

Visualization: Toxicity Pathways

The following diagram illustrates the divergent pathways of pharmacological efficacy versus toxicity for this scaffold.

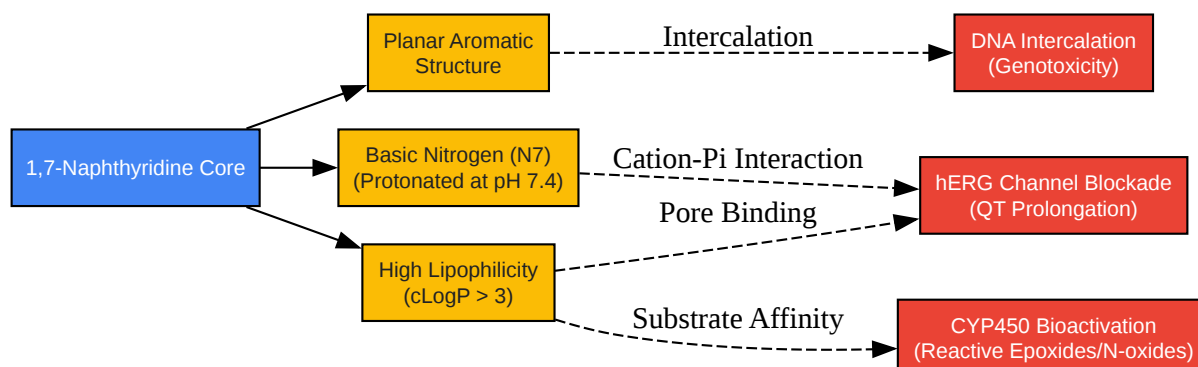

[Click to download full resolution via product page](#)

Caption: Mechanistic correlation between the physicochemical properties of the 1,7-naphthyridine scaffold and its primary toxicological liabilities.

Safety Data Sheet (SDS) Deep Dive

When reviewing or authoring an SDS for a novel 1,7-naphthyridine derivative, pay special attention to these sections.

Section 7: Handling and Storage

- **Hygroscopicity:** Many naphthyridine salts (e.g., hydrochloride) are hygroscopic. Moisture absorption can alter stoichiometry and lead to hydrolysis.
- **Storage:** Store at 2–8°C under an inert atmosphere (Argon/Nitrogen).
- **Light Sensitivity:** Protect from light. The conjugated system can undergo photodegradation.

Section 8: Exposure Controls / Personal Protection

- **Engineering Controls:** Use a Class II Biological Safety Cabinet (BSC) or a chemical fume hood with HEPA filtration if handling powder.

- Respiratory Protection: If N95/P100 respirators are insufficient due to the compound's potency (e.g., $< 10 \mu\text{M}$ potency), use a Powered Air Purifying Respirator (PAPR).
- Glove Permeability: Nitrile gloves are generally effective, but double-gloving is mandatory for concentrated solutions (DMSO stocks).

Section 11: Toxicological Information (Required Data Set)

For a complete profile, the following assays must be documented:

- Ames Test: (Salmonella typhimurium strains TA98, TA100) +/- S9 activation.
- hERG Patch Clamp: Automated or manual patch clamp IC50.
- Microsomal Stability: Intrinsic clearance (CLint) in human/mouse liver microsomes.

Experimental Protocols for Safety Profiling

Self-validating workflows for assessing the safety of your specific derivative.

Protocol A: In Vitro hERG Inhibition Assay (Automated Patch Clamp)

Purpose: To quantify cardiac risk early in the lead optimization phase.

- Cell Line Preparation: Use CHO (Chinese Hamster Ovary) or HEK293 cells stably expressing the hERG potassium channel.
- Solution Setup:
 - Extracellular Solution: HEPES-buffered Tyrode's solution (pH 7.4).
 - Intracellular Solution: KCl-based pipette solution (pH 7.2).
- Dosing: Prepare 1,7-naphthyridine derivative in DMSO. Final DMSO concentration must be $< 0.1\%$ to avoid vehicle effects. Test at concentrations: 0.1, 1, 10, and 30 μM .

- Voltage Protocol:
 - Hold at -80 mV.
 - Depolarize to +40 mV for 2 seconds (activates channels).
 - Repolarize to -50 mV for 2 seconds (elicits tail current).
- Data Analysis: Measure the peak tail current amplitude. Calculate % inhibition relative to vehicle control.
 - Validation Criteria: Positive control (E-4031, IC50 ~10-50 nM) must show >80% block.
 - Threshold: An IC50 < 10 μ M flags the compound for structural modification (e.g., reducing N7 basicity) [1].

Protocol B: Reactive Metabolite Trapping (Glutathione Assay)

Purpose: To detect bioactivation potential (epoxide/quinone-imine formation).

- Incubation: Incubate test compound (10 μ M) with Human Liver Microsomes (1 mg/mL) and NADPH (1 mM) in phosphate buffer (pH 7.4).
- Trapping Agent: Add Glutathione (GSH) at 5 mM.
- Time Course: Incubate for 60 minutes at 37°C.
- Termination: Quench with ice-cold acetonitrile. Centrifuge to remove protein.
- Analysis: Analyze supernatant via LC-MS/MS.
 - Search: Look for [M + GSH + O - 2H] or [M + GSH] adducts.
 - Interpretation: The presence of GSH adducts indicates the formation of reactive electrophiles, necessitating a redesign of the scaffold (e.g., blocking metabolic soft spots with Fluorine).

Handling & Emergency Workflow

The following decision tree outlines the immediate response to a spill or exposure event involving 1,7-naphthyridine solids or solutions.

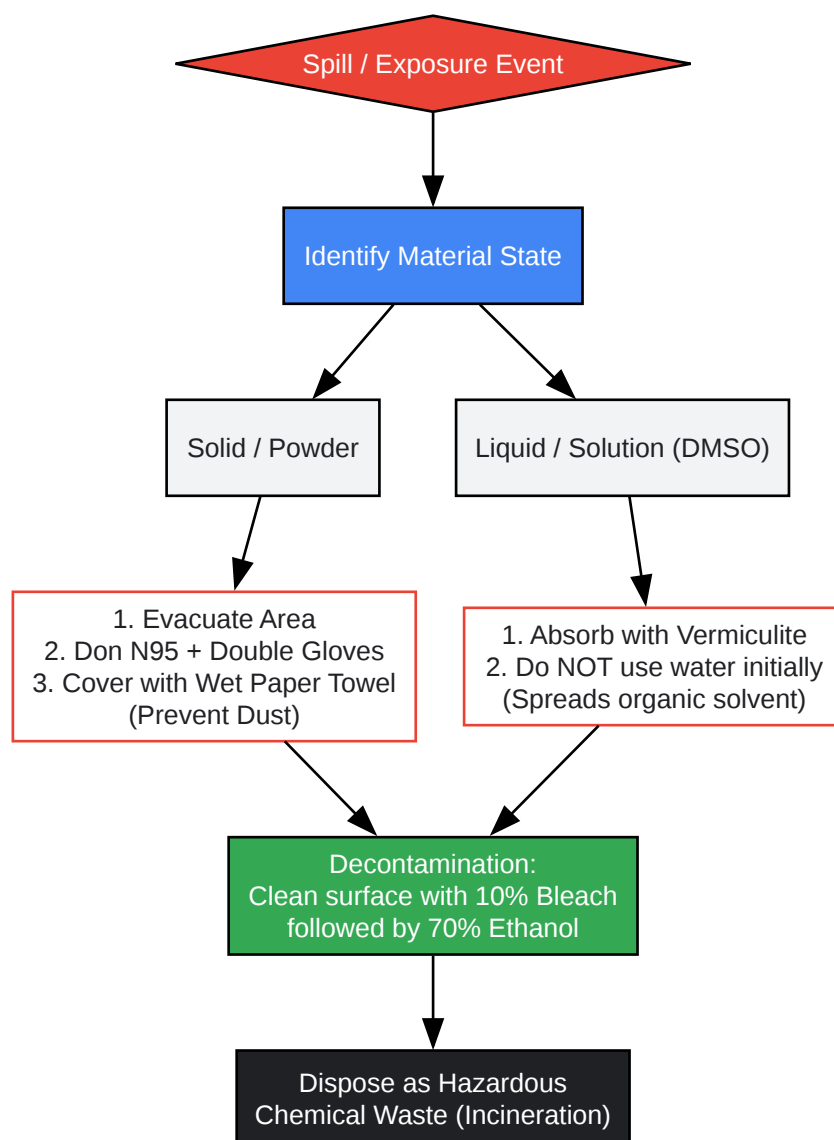

[Click to download full resolution via product page](#)

Caption: Emergency response workflow for 1,7-naphthyridine spills, prioritizing containment of dust and organic solvents.

References

- Hillig, R. C., et al. "Lead Identification of Novel Naphthyridine Derivatives as Potent SOS1 Inhibitors." ACS Medicinal Chemistry Letters, 2019. [Link](#)
 - Relevance: Discusses hERG liability of the scaffold and strategies to mitig
- Tomašič, T., et al. "Diminishing hERG inhibitory activity of aminopiperidine-naphthyridine linked NBTI antibacterials by structural and physicochemical optimizations." Bioorganic Chemistry, 2022.[2] [Link](#)
 - Relevance: Provides direct SAR data on hERG inhibition and antibacterial potency.
- Guengerich, F. P. "Mechanisms of Cytochrome P450-Catalyzed Oxidations." Chemical Research in Toxicology, 2001. [Link](#)
 - Relevance: Foundational text on the oxidative bioactiv
- ICH M7(R1). "Assessment and Control of DNA Reactive (Mutagenic) Impurities in Pharmaceuticals to Limit Potential Carcinogenic Risk." International Council for Harmonisation, 2017. [Link](#)
 - Relevance: Regulatory framework for assessing mutagenicity of heterocyclic scaffolds.

Need Custom Synthesis?

BenchChem offers custom synthesis for rare earth carbides and specific isotopic labeling.

Email: info@benchchem.com or [Request Quote Online](#).

Sources

- 1. [researchgate.net](https://www.researchgate.net) [[researchgate.net](https://www.researchgate.net)]
- 2. [Diminishing hERG inhibitory activity of aminopiperidine-naphthyridine linked NBTI antibacterials by structural and physicochemical optimizations](https://pubmed.ncbi.nlm.nih.gov/) - PubMed [pubmed.ncbi.nlm.nih.gov]
- To cite this document: BenchChem. [Technical Guide: Toxicity Profiling & Safety Management of 1,7-Naphthyridine Derivatives]. BenchChem, [2026]. [Online PDF]. Available at: [<https://www.benchchem.com/product/b7950191/docs#technical-guide-toxicity-profiling-safety-management-of-1-7-naphthyridine-derivatives>]

Disclaimer & Data Validity:

The information provided in this document is for Research Use Only (RUO) and is strictly not intended for diagnostic or therapeutic procedures. While BenchChem strives to provide accurate protocols, we make no warranties, express or implied, regarding the fitness of this product for every specific experimental setup.

Technical Support: The protocols provided are for reference purposes. Unsure if this reagent suits your experiment?

Need Industrial/Bulk Grade? [Request Custom Synthesis Quote](#)

BenchChem

Our mission is to be the trusted global source of essential and advanced chemicals, empowering scientists and researchers to drive progress in science and industry.

Contact

Address: 3281 E Guasti Rd

Ontario, CA 91761, United States

Phone: (601) 213-4426

Email: info@benchchem.com

[Contact our Ph.D. Support Team for a compatibility check](#)