

Comparative Analysis of Reductive Kinetics: Sodium Dithionite vs. Sodium Formaldehyde Bisulfite[1]

Author: BenchChem Technical Support Team. **Date:** May 2026

Compound of Interest

Compound Name: sodium;formaldehyde;hydrogen sulfite

Cat. No.: B7949673

[Get Quote](#)

Executive Summary

For researchers selecting a reducing agent, the choice between Sodium Dithionite (SDT) and Sodium Formaldehyde Bisulfite (SFB) represents a trade-off between thermodynamic power and kinetic stability.[1]

- Sodium Dithionite (SDT) is a high-potential "sledgehammer" (V), capable of reducing refractory chemical bonds (e.g., conjugated ketones, disulfides, vat dyes) almost instantaneously.[1] However, it suffers from rapid oxidative degradation and pH sensitivity.[1]
- Sodium Formaldehyde Bisulfite (SFB) is a "masked" source of bisulfite (V to V). It offers exceptional stability and controlled release but lacks the thermodynamic potential

to drive deep reductions. It is best utilized as an oxygen scavenger, preservative, or mild reductant for highly reactive electrophiles (e.g., active aldehydes, chlorine).[1]

Verdict: Use SDT for deep reductions (protein disulfides, vat dyeing, nitro reduction).[1] Use SFB for mild preservation, antioxidant buffering, or when the instability of SDT cannot be tolerated and the target is easily reduced.

Mechanistic Underpinnings

Sodium Dithionite (SDT): The Radical Anion Mechanism

SDT operates via a homolytic bond cleavage of the sulfur-sulfur bond. In solution, the dithionite anion (

) exists in equilibrium with the sulfonyl radical anion (

), which is the active reducing species.[1] This radical nature explains its high reactivity and fast kinetics.

[1]

Sodium Formaldehyde Bisulfite (SFB): The Dissociation Mechanism

SFB is a stable adduct. It does not reduce directly; it must first dissociate to release formaldehyde and the active bisulfite ion (

). The reducing power is limited to that of free bisulfite, which typically oxidizes to sulfate (

).

[1]

The equilibrium heavily favors the adduct, resulting in a "slow-release" mechanism that provides longevity but low instantaneous concentration of the reductant.

Pathway Visualization

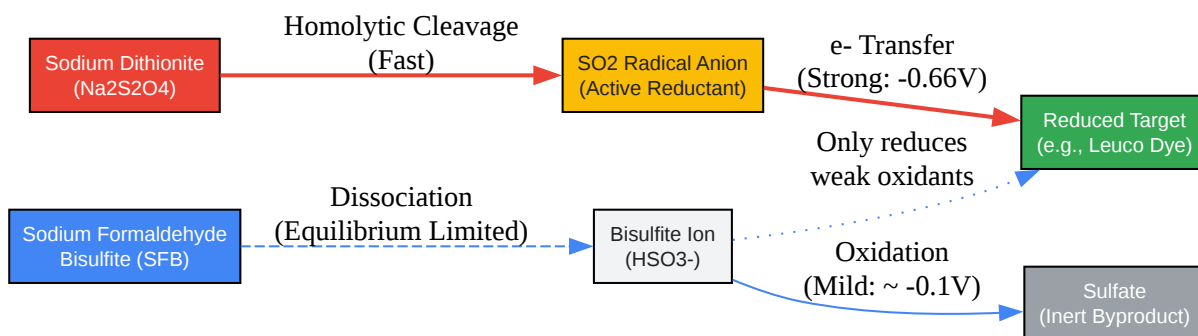

[Click to download full resolution via product page](#)

Figure 1: Mechanistic comparison showing the direct radical generation of SDT versus the dissociation-dependent pathway of SFB.[1]

Performance Metrics Comparison

The following data contrasts the physicochemical properties critical for experimental design.

Feature	Sodium Dithionite (SDT)	Sodium Formaldehyde Bisulfite (SFB)
Active Species	Sulfonyl Radical ()	Bisulfite Ion ()
Redox Potential ()	-0.66 V (at pH 7) to -0.90 V (at pH 10)	-0.10 V (approx.[1] effective potential)
Reducing Power	Very Strong (Reduces Indigo, Disulfides)	Mild (Reduces Chlorine, Quinones,)
Kinetics	Instantaneous (Milliseconds to Seconds)	Slow / Controlled (Minutes to Hours)
Stability (Solid)	Poor (Auto-ignites if damp/acidic)	Excellent (Stable crystalline powder)
Stability (Solution)	Half-life < 1 hour (pH < 7)	Stable for days/weeks
Byproducts	Thiosulfate, Sulfite, (smell!)[1][3]	Formaldehyde, Sulfate
pH Tolerance	Unstable below pH 6	Stable across pH 4–10

Experimental Protocols for Validation

To empirically verify the reducing power difference in your specific matrix, use the Differential Dye Reduction Assay. This self-validating system uses two redox indicators with distinct potential thresholds.

Protocol: Differential Dye Reduction Assay

Objective: Determine if the reducing agent is strong enough for deep reduction (SDT-level) or only mild reduction (SFB-level).

Materials:

- Indicator A (Low Barrier): Methylene Blue (V). Blue (Ox) Colorless (Red).
- Indicator B (High Barrier): Indigo Carmine (V). Blue (Ox) Yellow (Red).
- Buffer: 100 mM Phosphate Buffer, pH 7.0 (degassed).

Workflow:

- Preparation: Prepare 0.01% (w/v) solutions of Methylene Blue and Indigo Carmine in degassed buffer.
- Control: Aliquot 2 mL of each dye into separate cuvettes.
- SDT Test: Add 10 mg of Sodium Dithionite to one set of cuvettes. Cap and invert immediately.
 - Expected Result: Both Methylene Blue and Indigo Carmine turn colorless/yellow instantly.
- SFB Test: Add 10 mg of Sodium Formaldehyde Bisulfite to the second set. Cap and invert. Monitor for 30 minutes.
 - Expected Result: Methylene Blue may slowly fade (over minutes). Indigo Carmine will remain blue (SFB lacks the potential to reduce Indigo).

Interpretation:

- If your target molecule behaves like Indigo Carmine, SFB will fail; you must use SDT (or SFS).[1]
- If your target behaves like Methylene Blue, SFB is a viable, stable alternative.[1]

Decision Matrix & Application Guide

Use the following logic flow to select the appropriate reagent for your workflow.

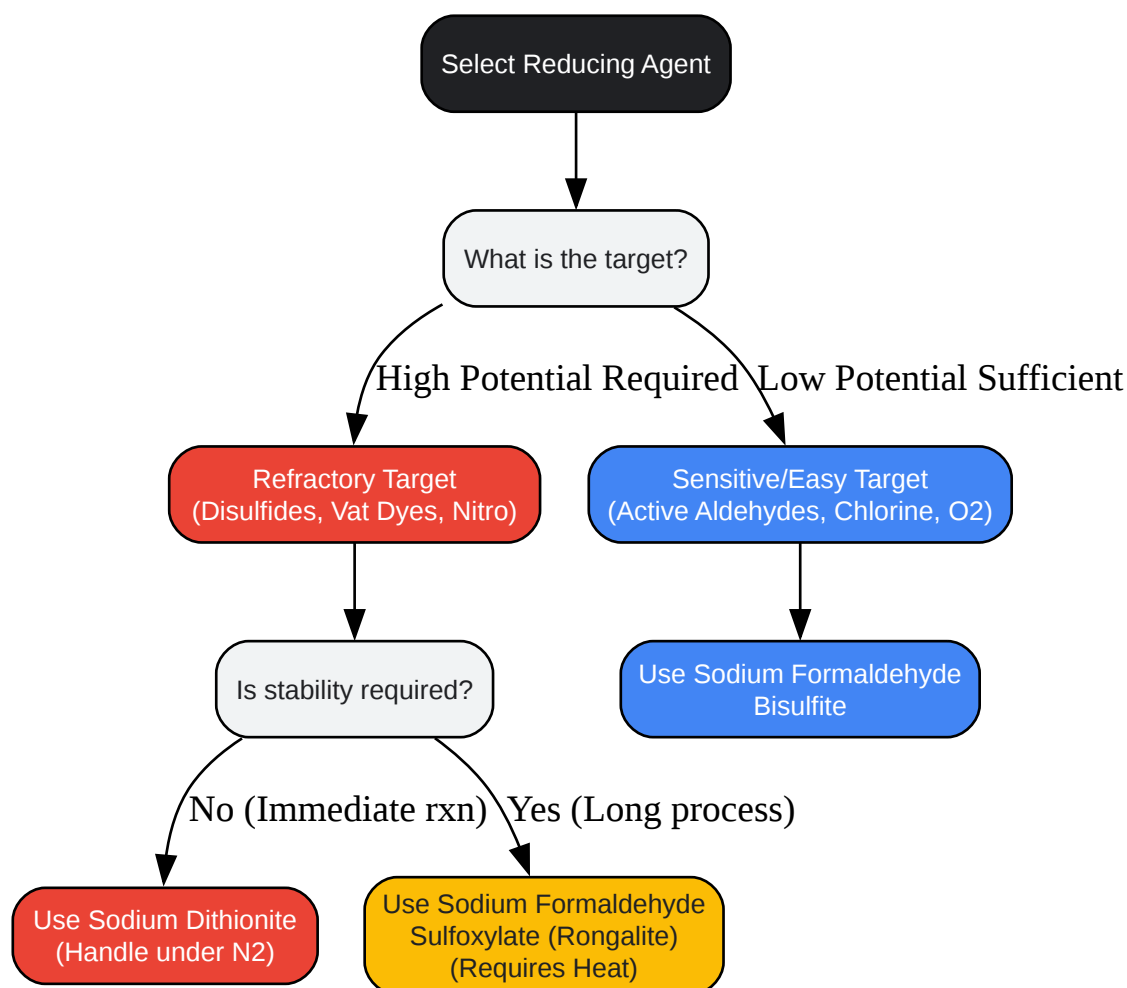

[Click to download full resolution via product page](#)

Figure 2: Decision tree for selecting sulfur-based reducing agents.[1]

Critical Application Notes:

- Protein Crystallography: SDT is the standard for preventing oxidative damage or stripping cofactors. SFB is generally ineffective here due to its inability to maintain a highly negative environment (<-0.5V).
- Excipient Stabilization: SFB is preferred in drug formulations (e.g., epinephrine injections) to prevent oxidative browning. SDT is too reactive and would degrade the API.

- Chemical Synthesis: If the protocol calls for "Sodium Formaldehyde Bisulfite" to reduce a nitro group, verify the CAS number. It is likely a translation error referring to Sodium Formaldehyde Sulfoxylate (Rongalite). SFB will not reduce nitro groups.

References

- Mayhew, S. G. (1978). The Redox Potential of Dithionite and SO₂- from Equilibrium Reactions with Flavodoxins, Methyl Viologen and Hydrogen plus Hydrogenase. European Journal of Biochemistry. [Link\[1\]](#)
- Vries, J. G., & Kellogg, R. M. (1980).[1][4] Reduction of Aldehydes and Ketones by Sodium Dithionite. Journal of Organic Chemistry. [Link\[1\]](#)
- National Center for Biotechnology Information (NCBI).PubChem Compound Summary for CID 2723822: Sodium Formaldehyde Bisulfite. [Link](#)
- Cultural Heritage Science. (2011). A Comparison of the Use of Sodium Metabisulfite and Sodium Dithionite for Removing Rust Stains. The Book and Paper Group Annual.[5] [Link](#)
- American Chemical Society (ACS). (2019). Molecule of the Week: Sodium Formaldehydesulfoxylate (Distinction from Bisulfite adduct). [Link](#)

Need Custom Synthesis?

BenchChem offers custom synthesis for rare earth carbides and specific isotopic labeling.

Email: info@benchchem.com or [Request Quote Online](#).

Sources

- 1. atamankimya.com [atamankimya.com]
- 2. BAuA - SUBSPORTplus - Datenbank Fallbeispiele – Details - Bundesanstalt für Arbeitsschutz und Arbeitsmedizin [subsportplus.eu]
- 3. Sodium Formaldehyde Bisulfite | CH₃NaO₄S | CID 2723822 - PubChem [pubchem.ncbi.nlm.nih.gov]
- 4. pure.rug.nl [pure.rug.nl]

- [5. cool.culturalheritage.org \[cool.culturalheritage.org\]](https://cool.culturalheritage.org)
- To cite this document: BenchChem. [Comparative Analysis of Reductive Kinetics: Sodium Dithionite vs. Sodium Formaldehyde Bisulfite[1]]. BenchChem, [2026]. [Online PDF]. Available at: [<https://www.benchchem.com/product/b7949673/docs#comparative-analysis-of-reductive-kinetics-sodium-dithionite-vs-sodium-formaldehyde-bisulfite-1>]

Disclaimer & Data Validity:

The information provided in this document is for Research Use Only (RUO) and is strictly not intended for diagnostic or therapeutic procedures. While BenchChem strives to provide accurate protocols, we make no warranties, express or implied, regarding the fitness of this product for every specific experimental setup.

Technical Support: The protocols provided are for reference purposes. Unsure if this reagent suits your experiment?

Need Industrial/Bulk Grade? [Request Custom Synthesis Quote](#)

BenchChem

Our mission is to be the trusted global source of essential and advanced chemicals, empowering scientists and researchers to drive progress in science and industry.

Contact

Address: 3281 E Guasti Rd
Ontario, CA 91761, United States
Phone: (601) 213-4426
Email: info@benchchem.com

[Contact our Ph.D. Support Team for a compatibility check](#)