

# Technical Guide: 3-(Ethylamino)-pentanoic Acid and Structural Analogs

**Author:** BenchChem Technical Support Team. **Date:** April 2026

## Compound of Interest

Compound Name: 3-(Ethylamino)-pentanoic acid

Cat. No.: B7939953

Get Quote

## Executive Summary

**3-(Ethylamino)-pentanoic acid** (CAS 1539722-71-8) represents a distinct class of

-alkylated

-amino acids.[1] As a linear structural analog of both

-aminobutyric acid (GABA) and clinically significant gabapentinoids (e.g., Pregabalin), this scaffold offers a versatile platform for exploring inhibitory neurotransmission modulation and peptidomimetic design.[1]

This guide provides a rigorous analysis of the **3-(ethylamino)-pentanoic acid** scaffold, detailing its synthesis via Aza-Michael addition, structure-activity relationship (SAR) strategies for analog generation, and pharmacological relevance in targeting the

subunit of voltage-gated calcium channels.[1]

## Structural Analysis & Chemical Space

### The Core Scaffold

The molecule consists of a five-carbon aliphatic backbone (pentanoic acid) with an ethyl-substituted amino group positioned at the

-carbon (C3).[1]

- IUPAC Name: 3-(Ethylamino)pentanoic acid[1][2]

- Chemical Class:

  - Amino Acid / GABA Analog[1]

- Key Features:

  - -Positioning: Unlike naturally occurring

    - amino acids, the amine is on the C3, conferring resistance to proteolytic degradation.[1]

  - -Ethylation: Increases lipophilicity (

    - ) compared to the primary amine, potentially enhancing blood-brain barrier (BBB) permeability via Large Neutral Amino Acid Transporter (LAT1) recognition, provided the zwitterionic character is masked or transported.[1]

  - Chirality: The C3 position is a stereocenter.[1] Biological activity is often stereospecific (e.g., (S)-Pregabalin is the active enantiomer; similar stereodependence is expected here).[1]

## Structural Homology

The scaffold sits at the intersection of several bioactive chemical series:

Compound	Structure	Relation to Target
GABA	4-Aminobutanoic acid	Endogenous inhibitory neurotransmitter.[1]
-Alanine	3-Aminopropanoic acid	Endogenous neuromodulator; glycine receptor agonist.[1]
Pregabalin	3-(Aminomethyl)-5-methylhexanoic acid	ligand; branched lipophilic tail. [1]
3-(Ethylamino)-pentanoic acid	3-(Ethylamino)pentanoic acid	Linear lipophilic backbone; -ethylated.[1]

## Design of Structural Analogs (SAR Strategy)

To optimize this scaffold for specific therapeutic endpoints (e.g., neuropathic pain, epilepsy, or foldamer stability), a systematic Structure-Activity Relationship (SAR) campaign is required.[1]

### SAR Logic & Diagram

The modification of **3-(ethylamino)-pentanoic acid** focuses on three vectors:

- Backbone Chain Length: Modulates receptor pocket fit (C4 vs C5 vs C6).
- -Substitution: Tunes basicity and lipophilicity.
- -Branching: Restricts conformational freedom (Thorpe-Ingold effect).[1]

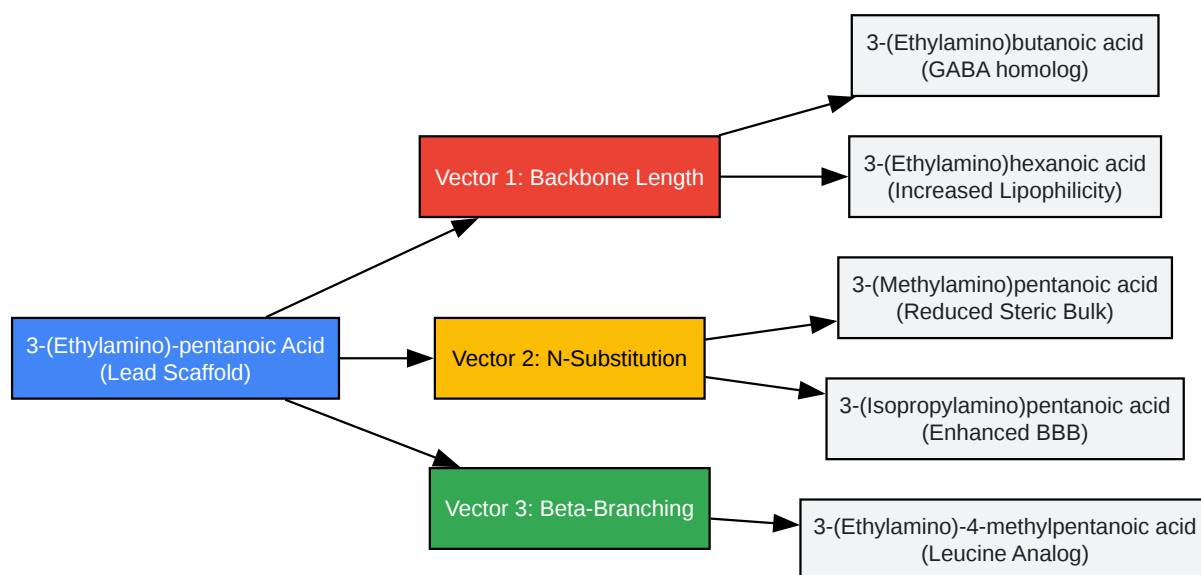

[Click to download full resolution via product page](#)

Figure 1: Strategic modification vectors for the **3-(ethylamino)-pentanoic acid** scaffold.

## Key Analogs Table

Analog ID	Structure Name	Rationale for Synthesis
ANA-001	3-(Methylamino)pentanoic acid	Reduces steric bulk at nitrogen; probes H-bond donor capacity.[1]
ANA-002	3-(Ethylamino)-4-methylpentanoic acid	Introduces isopropyl branching (Valine-like); mimics Pregabalin's bulk.[1]
ANA-003	3-(Cyclopropylamino)pentanoic acid	Rigidifies the -substituent; prevents metabolic dealkylation.[1]
ANA-004	3-(Ethylamino)-3-phenylpropanoic acid	Aromatic stacking potential; analog of -phenylalanine.[1]

## Synthesis Protocols

The most robust route to

-alkyl-

-amino acids is the Aza-Michael Addition.[1] This method is atom-economical and scalable.[1]

### Workflow Diagram

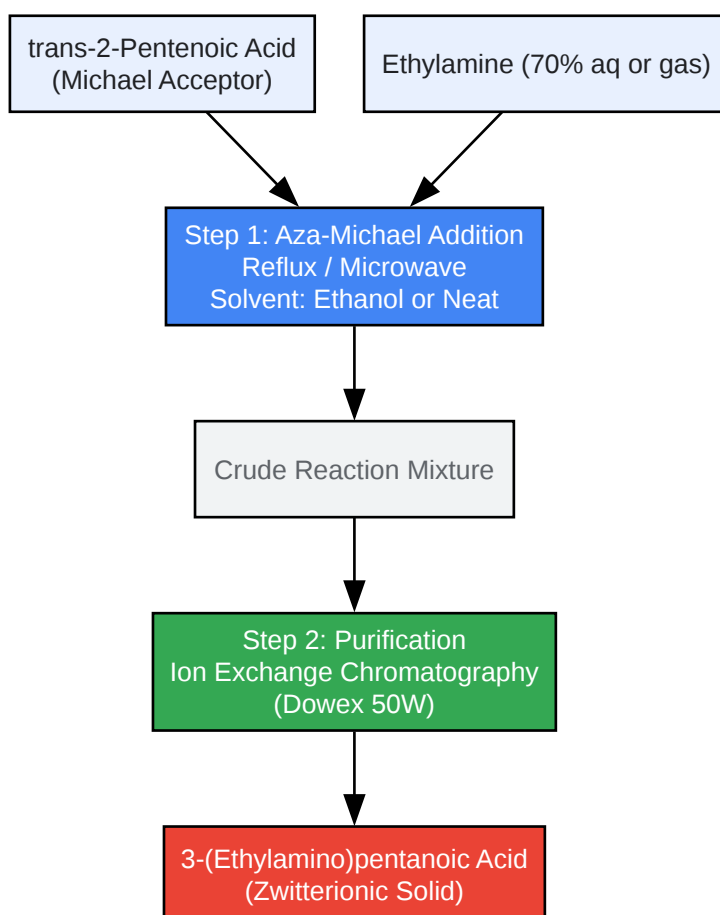

[Click to download full resolution via product page](#)

Figure 2: Aza-Michael synthesis pathway for **3-(ethylamino)-pentanoic acid**.

## Detailed Experimental Protocol

Objective: Synthesis of 3-(ethylamino)pentanoic acid via conjugate addition.

Reagents:

- trans-2-Pentenoic acid (10 mmol)[1]
- Ethylamine (20 mmol, 70% aqueous solution or 2M in THF)[1]
- Ethanol (Absolute)[1]

#### Procedure:

- Setup: In a 50 mL pressure tube or round-bottom flask equipped with a reflux condenser, dissolve trans-2-pentenoic acid (1.0 g, 10 mmol) in Ethanol (10 mL).
- Addition: Add Ethylamine (excess, 2.0 eq) dropwise at 0°C to control exotherm.
- Reaction: Seal the tube (if using pressure vessel) and heat to 80°C for 12–24 hours. Alternatively, use microwave irradiation at 100°C for 1 hour to accelerate kinetics.[1]
- Monitoring: Monitor consumption of the acrylate via TLC (System: n-Butanol/Acetic Acid/Water 4:1:1, stain with Ninhydrin).
- Workup: Concentrate the reaction mixture in vacuo to remove solvent and excess amine.
- Purification (Critical Step):
  - Dissolve the residue in minimal distilled water.[1]
  - Load onto a column of Dowex 50W-X8 cation exchange resin (H<sup>+</sup> form).[1]
  - Wash with water until neutral (removes unreacted acid).[1]
  - Elute the product with 1M  
[1]
- Isolation: Lyophilize the ammoniacal fractions to yield the target  
-amino acid as a white zwitterionic powder.

#### Validation:

- <sup>1</sup>H NMR ( ): Look for the disappearance of alkene protons ( 5.8–7.0 ppm) and appearance of the -CH multiplet ( 3.0–3.5 ppm).[1]
- MS (ESI):  
calculated for  
: 146.11; Found: 146.1.[1]

## Pharmacological Applications[1][3][4]

### Target Systems

- Subunit (Voltage-Gated Calcium Channels):
  - Gabapentinoids bind to this subunit to reduce calcium influx and neurotransmitter release. [1]
  - Hypothesis: The ethyl group at the nitrogen may provide additional hydrophobic contacts within the binding pocket, although excessive bulk can hinder binding compared to the primary amine of Pregabalin.[1]
- GABA Transporters (GAT):
  - -alkylated GABA analogs often show reduced affinity for receptors but may act as transport inhibitors.[1]
- Peptidomimetics ( -Peptides):
  - Incorporation of **3-(ethylamino)-pentanoic acid** into peptide backbones creates "foldamers" with specific secondary structures (helices/sheets) that are resistant to proteolytic degradation.[1]

## In Vitro Metabolic Stability

-alkylation is a common strategy to protect amines from metabolic deamination.[1] However, the ethyl group itself is subject to oxidative dealkylation by CYP450 enzymes.[1]

Protocol: Microsomal Stability Assay

- Incubation: Incubate test compound (1 M) with pooled liver microsomes (human/rat) and NADPH regenerating system at 37°C.
- Sampling: Quench aliquots at 0, 15, 30, and 60 mins with acetonitrile containing internal standard.
- Analysis: Analyze via LC-MS/MS.
- Calculation: Determine intrinsic clearance ( ) based on the depletion rate constant ( ).
  - Expectation: The -ethyl group may be slowly removed to yield the primary amine metabolite (3-aminopentanoic acid).[1]

## References

- Synthesis of -Amino Acids:
  - Title: Aza-Michael Mono-addition Using Acidic Alumina under Solventless Conditions
  - Source: MDPI (Molecules)[1]
  - URL: [\[Link\]](#)[1]
- Pharmacology of Gabapentinoids
  - Title: Preparation of beta-amino acids having affinity for the alpha-2-delta protein

- Source: Google Patents (Pfizer/Warner-Lambert)[1]
- URL: [1]
- Peptidomimetics & Foldamers
  - Title: Peptides Containing -Amino Acid Patterns: Challenges and Successes in Medicinal Chemistry
  - Source: ACS Publications (Journal of Medicinal Chemistry)[1]
  - URL: [Link][1]
- Chemical Data
  - Title: **3-(Ethylamino)-pentanoic acid** Product Page
  - Source: Sigma-Aldrich[1]

### *Need Custom Synthesis?*

BenchChem offers custom synthesis for rare earth carbides and specific isotopic labeling.

Email: [info@benchchem.com](mailto:info@benchchem.com) or [Request Quote Online](#).

## Sources

- [1. Aza-Michael Mono-addition Using Acidic Alumina under Solventless Conditions | MDPI \[mdpi.com\]](#)
- [2. 3-\(Ethylamino\)-pentanoic acid \[sigmaaldrich.com\]](#)
- To cite this document: BenchChem. [Technical Guide: 3-(Ethylamino)-pentanoic Acid and Structural Analogs]. BenchChem, [2026]. [Online PDF]. Available at: [\[https://www.benchchem.com/product/b7939953/docs#technical-guide-3-ethylamino-pentanoic-acid-and-structural-analogs\]](https://www.benchchem.com/product/b7939953/docs#technical-guide-3-ethylamino-pentanoic-acid-and-structural-analogs)

---

### Disclaimer & Data Validity:

The information provided in this document is for Research Use Only (RUO) and is strictly not intended for diagnostic or therapeutic procedures. While BenchChem strives to provide accurate protocols, we make no warranties, express or implied, regarding the fitness of this product for every specific experimental setup.

**Technical Support:** The protocols provided are for reference purposes. Unsure if this reagent suits your experiment?

**Need Industrial/Bulk Grade?** [Request Custom Synthesis Quote](#)

## BenchChem

Our mission is to be the trusted global source of essential and advanced chemicals, empowering scientists and researchers to drive progress in science and industry.

### Contact

Address: 3281 E Guasti Rd  
Ontario, CA 91761, United States  
Phone: (601) 213-4426  
Email: [info@benchchem.com](mailto:info@benchchem.com)

[Contact our Ph.D. Support Team for a compatibility check](#)