

Application Notes and Protocols for Flow Cytometry Analysis with BMS CCR2 22

Author: BenchChem Technical Support Team. **Date:** April 2026

Compound of Interest

Compound Name: *Bms ccr2 22*

Cat. No.: *B7909903*

[Get Quote](#)

For Researchers, Scientists, and Drug Development Professionals

Introduction

BMS CCR2 22 is a potent and selective antagonist of the C-C chemokine receptor 2 (CCR2), a key mediator in the inflammatory response.[1] CCR2 and its primary ligand, CCL2 (also known as MCP-1), play a crucial role in the recruitment of monocytes and macrophages to sites of inflammation and are implicated in various inflammatory and autoimmune diseases, as well as in cancer metastasis.[2][3][4] As a high-affinity antagonist, **BMS CCR2 22** offers a powerful tool for studying the biological functions of the CCL2-CCR2 axis and for the development of novel therapeutics.

These application notes provide detailed protocols for utilizing **BMS CCR2 22** in flow cytometry-based assays to characterize its inhibitory effects on CCR2 function. The provided methodologies are designed to guide researchers in assessing CCR2 expression, inhibition of ligand-induced receptor internalization, and blockade of chemotaxis.

Mechanism of Action

BMS CCR2 22 is a high-affinity, specific antagonist of CCR2. It exerts its inhibitory effects by binding to CCR2 and preventing the downstream signaling events induced by CCL2. This includes the inhibition of calcium mobilization and the blockade of monocyte migration.

Quantitative Data Summary

The following tables summarize the key in vitro inhibitory activities of **BMS CCR2 22**.

Parameter	IC50 Value (nM)	Cell Type/Assay Condition
CCR2 Binding Affinity	5.1	Radioligand binding assay using peripheral blood mononuclear cells (PBMCs)
Calcium Flux Inhibition	18	Inhibition of CCL2-induced calcium flux
Chemotaxis Inhibition	1	Inhibition of CCL2-induced chemotaxis of PBMCs
Receptor Internalization	~2	Inhibition of fluorescently labeled hMCP-1 internalization in human monocytes

Experimental Protocols

Protocol 1: Analysis of CCR2 Expression on Human Monocytes by Flow Cytometry

This protocol details the procedure for staining human peripheral blood mononuclear cells (PBMCs) to identify and quantify the percentage of CCR2-expressing monocytes.

Materials:

- Human whole blood collected in EDTA tubes
- Ficoll-Paque PLUS
- Phosphate Buffered Saline (PBS)

- FACS Buffer (PBS + 2% FBS + 0.1% Sodium Azide)
- Anti-Human CD14 Antibody (e.g., FITC conjugated)
- Anti-Human CCR2 Antibody (e.g., PE conjugated)
- Isotype Control Antibodies (FITC and PE conjugated)
- 70 μ m cell strainer
- Flow cytometer

Procedure:

- PBMC Isolation: Isolate PBMCs from whole blood using Ficoll-Paque density gradient centrifugation according to the manufacturer's instructions.
- Cell Counting and Resuspension: Wash the isolated PBMCs twice with PBS and resuspend in FACS buffer. Perform a cell count and adjust the cell concentration to 1×10^7 cells/mL.
- Antibody Staining:
 - Aliquot 100 μ L of the cell suspension (1×10^6 cells) into flow cytometry tubes.
 - Add the recommended concentration of anti-human CD14-FITC and anti-human CCR2-PE antibodies to the respective tubes.
 - In separate tubes, add the corresponding isotype control antibodies.
 - Vortex gently and incubate for 30 minutes at 4°C in the dark.
- Washing: Add 2 mL of FACS buffer to each tube and centrifuge at 300 x g for 5 minutes. Discard the supernatant.
- Resuspension: Resuspend the cell pellet in 500 μ L of FACS buffer.
- Flow Cytometry Analysis: Acquire the samples on a flow cytometer. Gate on the monocyte population based on forward and side scatter characteristics, and then on CD14-positive

cells. Analyze the expression of CCR2 within the CD14+ monocyte gate.

Protocol 2: Inhibition of CCL2-Induced CCR2 Internalization using BMS CCR2 22

This protocol assesses the ability of **BMS CCR2 22** to block the internalization of CCR2 upon stimulation with its ligand, CCL2.

Materials:

- Isolated human PBMCs (as in Protocol 1)
- RPMI 1640 medium + 10% FBS
- Recombinant Human CCL2/MCP-1
- **BMS CCR2 22**
- Anti-Human CCR2 Antibody (e.g., APC conjugated)
- Flow cytometer

Procedure:

- Cell Preparation: Resuspend isolated PBMCs in RPMI 1640 + 10% FBS at a concentration of 2×10^6 cells/mL.
- **BMS CCR2 22** Pre-treatment:
 - Aliquot 500 μ L of the cell suspension into flow cytometry tubes.
 - Add varying concentrations of **BMS CCR2 22** (e.g., 0.1 nM to 100 nM) to the tubes. Include a vehicle control (e.g., DMSO).
 - Incubate for 30 minutes at 37°C.
- CCL2 Stimulation:

- Add a pre-determined optimal concentration of recombinant human CCL2 (e.g., 50 ng/mL) to all tubes except for the unstimulated control.
- Incubate for 45 minutes at 37°C to induce receptor internalization.
- Staining:
 - Place the tubes on ice to stop the internalization process.
 - Wash the cells once with cold FACS buffer.
 - Add the anti-human CCR2-APC antibody at the recommended concentration.
 - Incubate for 30 minutes at 4°C in the dark.
- Washing and Analysis:
 - Wash the cells once with cold FACS buffer.
 - Resuspend in 500 µL of FACS buffer and analyze by flow cytometry.
 - A decrease in the Mean Fluorescence Intensity (MFI) of CCR2 staining in the CCL2-stimulated sample compared to the unstimulated control indicates receptor internalization. The ability of **BMS CCR2 22** to prevent this decrease demonstrates its antagonistic activity.

Protocol 3: Chemotaxis Assay with Flow Cytometry

Readout

This protocol measures the inhibition of monocyte migration towards a CCL2 gradient by **BMS CCR2 22**.

Materials:

- Isolated human PBMCs
- Chemotaxis buffer (e.g., HBSS with 0.1% BSA)

- Recombinant Human CCL2/MCP-1
- **BMS CCR2 22**
- Transwell inserts (e.g., 5 µm pore size)
- 24-well plate
- Flow cytometer
- Counting beads for absolute cell counting

Procedure:

- Cell and Compound Preparation:
 - Resuspend PBMCs in chemotaxis buffer at 1×10^6 cells/mL.
 - Prepare serial dilutions of **BMS CCR2 22** in chemotaxis buffer.
 - Pre-incubate the cells with **BMS CCR2 22** or vehicle control for 30 minutes at 37°C.
- Chemotaxis Setup:
 - Add 600 µL of chemotaxis buffer containing CCL2 (e.g., 10 ng/mL) to the lower wells of the 24-well plate.
 - Add 100 µL of the pre-treated cell suspension to the upper chamber of the Transwell inserts.
 - Incubate the plate for 2-3 hours at 37°C in a 5% CO₂ incubator.
- Cell Collection and Analysis:
 - Carefully remove the Transwell inserts.
 - Collect the cells that have migrated to the lower chamber.
 - Add a known number of counting beads to each sample.

- Acquire the samples on a flow cytometer.
- Data Analysis:
 - Gate on the monocyte population.
 - Calculate the absolute number of migrated monocytes in each condition by comparing the cell counts to the bead counts.
 - Determine the percentage inhibition of chemotaxis by **BMS CCR2 22** compared to the vehicle control.

Visualizations

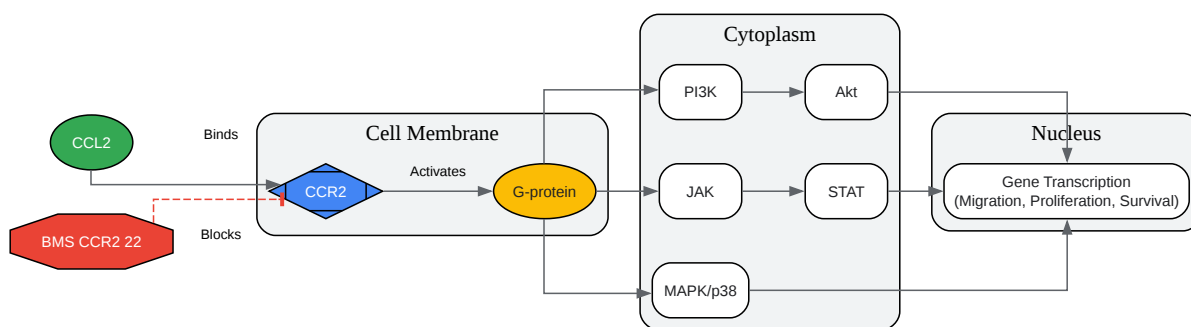

[Click to download full resolution via product page](#)

Caption: CCR2 Signaling Pathway and Inhibition by **BMS CCR2 22**.

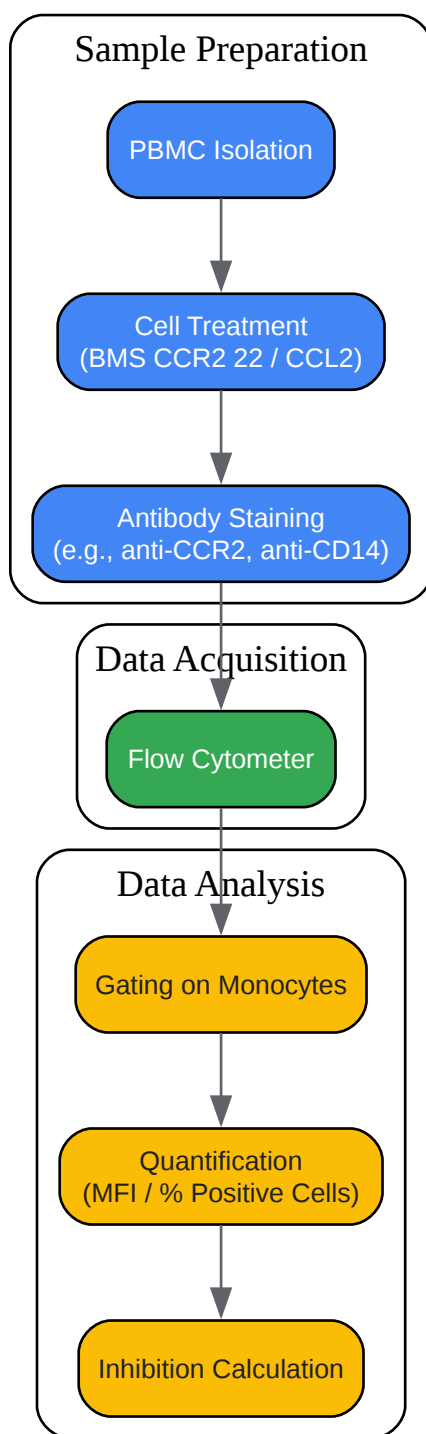

[Click to download full resolution via product page](#)

Caption: Experimental Workflow for Flow Cytometry Analysis.

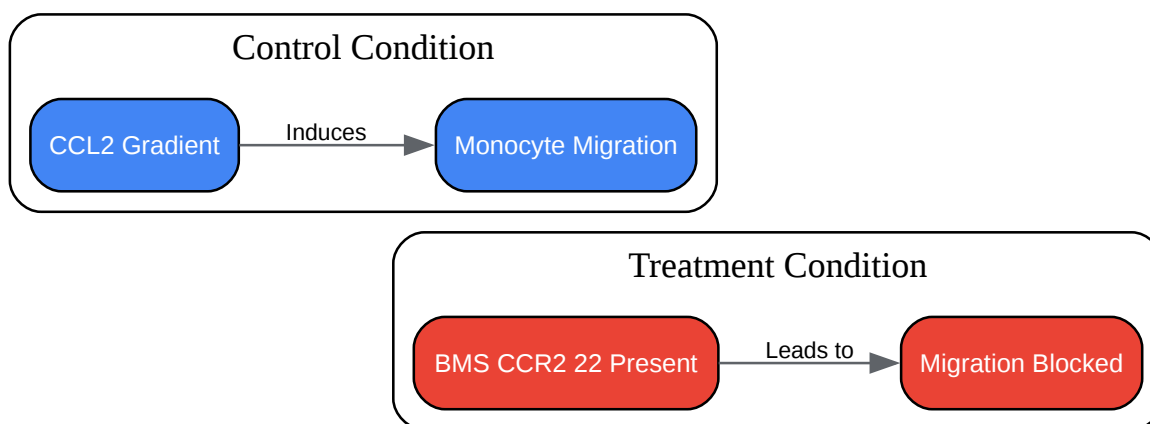

[Click to download full resolution via product page](#)

Caption: Logical Relationship in a Chemotaxis Assay.

Need Custom Synthesis?

BenchChem offers custom synthesis for rare earth carbides and specific isotopic labeling.

Email: info@benchchem.com or [Request Quote Online](#).

References

- 1. CCR2 and CXCR4 regulate peripheral blood monocyte pharmacodynamics and link to efficacy in experimental autoimmune encephalomyelitis - PMC [[pmc.ncbi.nlm.nih.gov](https://pubmed.ncbi.nlm.nih.gov/)]
- 2. Critical roles for CCR2 and MCP-3 in monocyte mobilization from bone marrow and recruitment to inflammatory sites - PMC [[pmc.ncbi.nlm.nih.gov](https://pubmed.ncbi.nlm.nih.gov/)]
- 3. Targeting CCR2 with its antagonist suppresses viability, motility and invasion by downregulating MMP-9 expression in non-small cell lung cancer cells - PMC [[pmc.ncbi.nlm.nih.gov](https://pubmed.ncbi.nlm.nih.gov/)]
- 4. Monocyte emigration from bone marrow during bacterial infection requires signals mediated by chemokine receptor CCR2 - PubMed [pubmed.ncbi.nlm.nih.gov]
- To cite this document: BenchChem. [Application Notes and Protocols for Flow Cytometry Analysis with BMS CCR2 22]. BenchChem, [2026]. [Online PDF]. Available at: [<https://www.benchchem.com/product/b7909903/docs#application-notes-and-protocols-for-flow-cytometry-analysis-with-bms-ccr2-22>]

Disclaimer & Data Validity:

The information provided in this document is for Research Use Only (RUO) and is strictly not intended for diagnostic or therapeutic procedures. While BenchChem strives to provide accurate protocols, we make no warranties, express or implied, regarding the fitness of this product for every specific experimental setup.

Technical Support: The protocols provided are for reference purposes. Unsure if this reagent suits your experiment?

Need Industrial/Bulk Grade? [Request Custom Synthesis Quote](#)

BenchChem

Our mission is to be the trusted global source of essential and advanced chemicals, empowering scientists and researchers to drive progress in science and industry.

Contact

Address: 3281 E Guasti Rd
Ontario, CA 91761, United States
Phone: (601) 213-4426
Email: info@benchchem.com

[Contact our Ph.D. Support Team for a compatibility check](#)